

Tuner Semiconductor Devices

Data Book 1986/87



Straightforward ordering with the catalog **“Siemens Components Service, Preferred Products”.**

Every year, a revised edition of the SCS catalog on Preferred Products is published. This catalog comprises preferred products of the entire Siemens components program including their main technical specs.

Orders for components as well as for the above mentioned catalog should be directed to your nearest Siemens Office, Components Division, or Distributor.

Published by Siemens AG, Bereich Bauelemente, Vertrieb, Produktinformation, Balanstraße 73, D-8000 München 80

For the circuits, descriptions and tables indicated no responsibility is assumed as far as patents or other rights of third parties are concerned.

The information describes the type of component and shall not be considered as assured characteristics. Terms of delivery and rights to change design reserved.

For questions on technology, delivery, and prices please contact the Offices of Siemens Aktiengesellschaft in the Federal Republic of Germany and Berlin (West) or the Siemens Companies and Representatives Worldwide (see list of Siemens Offices).

A comma in the outline drawings and tables represents the decimal point.
The sign Ø in drawings denotes diameter.

Table of Contents
Type Designation System



	Page
Type designation system	8
Type code	8
Type marking	9
Ordering code	9
Selection guide	12
Survey of types	12
Application reference table	14
Cross reference table of packages	16
Types and ordering codes in alphanumerical order	17
Explanation of data sheet parameters	20
Quality specifications	21
Packaging	24
Taping: TO 92 package	24
Taping: DO 35 package	25
Taping: SMD packages (for surface mounting)	26
Mounting instructions	27
ESD-sensitive devices	27
Heat dissipation	27
Mechanical stress	28
Soldering	28
Diodes — technical data	30
Transistors — technical data	82

Type Designation System

Type code

The European type code according to Pro Electron is made up of 2 letters (type of material and application) and a serial code consisting of 3 or more digits.

The first letter denotes the semiconductor material:

- A Germanium (or a band gap of 0.6—1 eV)
- B Silicon (or a band gap of 1—1.3 eV)
- C III—V material, e.g. gallium arsenide (or a band gap of more than 1.3 eV)
- D Material with a band gap of less than 0.6 eV, e.g. indium antimonide
- R Semiconductor compounds for photoconductive cells and Hall-effect devices

The second letter denotes the area of application:

- A Signal diode, low power
- B Capacitance diode
- C AF small signal transistor, $R_{thJC} > 15 \text{ K/W}$
- D AF power transistor, $R_{thJC} < 15 \text{ K/W}$
- E Tunnel diode
- F RF small signal transistor, $R_{thJC} > 15 \text{ K/W}$
- G Combination of components, array, multichip
- H Hall field probe
- L RF power transistor, $R_{thJC} < 15 \text{ K/W}$
- N Optocoupler
- P Radiation detector, e.g. photovoltaic cell
- Q Radiation emitter, e.g. light emitting diode
- R Low power switching element with thyristor characteristics, $R_{thJC} > 15 \text{ K/W}$
- S Low power switching transistor, $R_{thJC} > 15 \text{ K/W}$
- T High power switching element with thyristor characteristics, $R_{thJC} < 15 \text{ K/W}$
- V High power switching transistor, $R_{thJC} < 15 \text{ K/W}$
- X Frequency multiplication diode
- Y Power rectifier
- Z Transient voltage suppressor, Z diode, reference diode

The serial code of components designed for use in “entertainment” electronics is a three-digit number (e.g. BF 970), while that of components primarily used in “industrial” electronics equipment consists of one letter and a two-digit number (e.g. BXY 43).

An additional letter attached to the serial code is used to define a mechanical or electrical variant.

Other type designations based on the JEDEC system or internal nomenclature may be used.

Type marking

If the size of the component allows, the complete designation, the manufacturing date code (year — month in accordance with DIN 41314.1 or year, week in accordance with DIN 41314.2 or EIA) and the manufacturer's logotype (® or S) are printed on it. If there is insufficient space, short symbols as given in the data sheets are used. Color codes mentioned in the data sheets serve to differentiate types and groups.

Ordering code

The ordering codes for standard types are provided in the data sheets. Special versions manufactured on the basis of special supply contracts are assigned separate ordering codes.

Selection Guide

Survey of Types

Application Reference Table

Cross Reference Table of Packages

Types and Ordering Codes

Selection Guide

Survey of types Switching PIN diodes

Type	Characteristics ($T_A = 25^\circ\text{C}$)					Package	Page
	$V_{R\text{max}}$	$C_T (f = 1\text{ MHz})$	V_R	$r_f (f = 100\text{ MHz})$			
	V	pF	V	Ω	I_F mA		
BA 243	35	<2	15	<1	10	DO 35	30
BA 243 S	35	<1,5	5	<0,7	10	DO 35	32
BA 244	35	<2	15	<0,5	10	DO 35	30
BA 244 S	35	<1,5	5	<0,5	10	DO 35	32
BA 282	35	<1,2	3	<0,5	10	DO 35	34
BA 283	35	<1	3	<0,9	10	DO 35	34
BA 284	35	<1	20	<0,6	10	DO 35	36
▼BA 389	30	0,55	10	5	10	DO 35	38
▼BA 682	35	<1,2	3	<5	10	SOD 80	41
▼BA 683	35	<1	3	<0,9	10	SOD 80	41
▼BA 885	50	0,3	10	5	10	SOT 23	44

Tuning diodes

Type	$C_T (f = 1\text{ MHz})$	V_R	C_{T1}/C_{T2}	$V_{R1}; V_{R2}$	r_s	Package	Page
	pF	V	—	V; V	Ω		
▼BB 112	440...520	1	>18	1; 8,5	1,4	TO 92	46
BB 204 green	34...39	3	2,55...2,8	3; 30	0,2	TO 92	49
BB 204 blue	37...42	3	2,55...2,8	3; 30	0,2	TO 92	49
BB 304	42...47,5	2	1,65...1,75	2; 8	0,2	TO 92	52
▼BB 314	44,75	2	2,2	2; 8	0,25	TO 92	55
BB 409	4,5...5,6	25	5...6,5	3; 25	0,3	DO 35	57
BB 505 B	1,85...2,25	28	7,7...9,4	1; 28	0,62	DO 35	60
BB 505 G	1,8...2,4	28	7,5...9,5	1; 28	0,8	DO 35	60
▼BB 515 B	1,85...2,25	28	8...9,5	1; 28	0,55	Mini-plast	63
▼BB 515 G	1,8...2,4	28	7,5...9,5	1; 28	0,75	Mini-plast	63
BB 609 A	2,5...3	28	12...15	1; 28	0,7	DO 35	65
BB 609 B	2,8...3,2	28	12...15	1; 28	0,7	DO 35	65
▼BB 610	3,75	28	>19	1; 28	1,4	DO 35	67
▼BB 619 A	2,5...3	28	>12	1; 28	0,65	Mini-plast	69
▼BB 619 B	2,8...3,2	28	>12	1; 28	0,65	Mini-plast	69
▼BB 620	3,75	28	>19	1; 28	1,3	Mini-plast	71
▼BB 801	1	28	9	1; 28	1	SOT 23	73
▼BB 804	42...47,5	2	1,7	2; 8	0,25	SOT 23	75
▼BB 814	44,75	2	2,2	2; 8	0,25	SOT 23	78

▼ New types

Bipolar RF transistors

Type	Maximum ratings			Characteristics ($T_A = 25^\circ\text{C}$)						Package	Page	
	V_{CE0}	I_C	P_{tot}	h_{FE}	I_C	V_{CE}	F	f	f_T			
	V	mA	mW	—	mA	V	dB	MHz	MHz			
PNP-P												
NPN-N												
BF 199	N	25	25	500	85 (>38)	7	10			550	TO 92	82
BF 240	N	40	25	250	65...220	1	10	1,7	0,1	400	TO 92	86
BF 241	N	40	25	250	35...125	1	10	1,7	0,1	400	TO 92	86
BF 254	N	20	30	250	65...220	1	10	1,2	1	260	TO 92	89
BF 255	N	20	30	250	35...130	1	10	3,8	100	220	TO 92	89
BF 414	P	30	25	300	80 (>30)	4	10	3	100	560	TO 92	92
BF 450	P	40	25	250	65...220	1	10	2	0,1	375	TO 92	94
BF 451	P	40	25	250	35...125	1	10	3	100	325	TO 92	94
BF 506	P	35	30	300	>25	3	10	3	200	550	TO 92	99
▼BF 517	N	15	25	280	25...250	5	10	5	800	2000	SOT 23	101
BF 550	P	40	25	280	50...250	1	10	3,4	100	350	SOT 23	104
BF 554	N	20	30	280	60...250	1	10	3	100	250	SOT 23	109
BF 569	P	35	30	280	50 (>20)	3	10	4,5	800	950	SOT 23	113
BF 579	P	20	30	280	>20	10	10	4	800	1600	SOT 23	116
BF 599	N	25	25	280	70 (>38)	7	10			550	SOT 23	119
BF 606 A	P	30	25	300	>30	1	10			700	TO 92	123
BF 660	P	30	25	280	>30	3	10			700	SOT 23	125
BF 763	N	15	25	500	25...250	5	10	5	800	2000	TO 92	128
▼BF 770 A	N	12	50	280	90 (>40)	30	5	2	800	5500	SOT 23	130
▼BF 775	N	12	30	280	40...250	5	6	2,1	800	4500	SOT 23	133
BF 799	N	20	35	280	40...250	20	10	3	100	1100	SOT 23	136
BF 959	N	20	100	500	40...250	20	10	3	200	1100	TO 92	139
BF 970	P	35	30	160	50 (>25)	3	10	4,5	800	950	T-plast	187
BF 979 S	P	25	50	160	>20	10	10	3,5	800	1600	T-plast	189

MOS field-effect tetrodes

Type	Maximum ratings			Characteristics ($T_A = 25^\circ\text{C}$)						Package	Page
	V_{DS}	I_D	P_{tot}	g_{fs}	G_P	F	V_{DS}	I_D	f		
	V	mA	mW	mS	dB	dB	V	mA	MHz		
N channel											
BF 960	20	30	200	12	16,5	2,8	15	7	800	X-plast	142
BF 961	20	30	200	17	23	1,1	15	10	200	X-plast	152
BF 963	20	50	200	25	25	1,5	15	10	200	X-plast	162
▼BF 964 S	20	30	200	18	25	1,0	15	10	200	X-plast	168
▼BF 965	20	30	200	18	25	1,0	15	10	200	X-plast	174
▼BF 966 S	20	30	200	18	18	1,8	15	10	800	X-plast	180
▼BF 989	20	30	200	12	16,5	2,8	15	7	800	SOT 143	191
▼BF 993	20	50	200	25	25	1,5	15	10	200	SOT 143	201
▼BF 994 S	20	30	200	18	25	1,0	15	10	200	SOT 143	208
▼BF 995	20	30	200	17	23	1,1	15	10	200	SOT 143	214
▼BF 996 S	20	30	200	18	18	1,8	15	10	800	SOT 143	224
▼BF 997	20	30	200	18	25	1,0	15	10	200	SOT 143	232

▼ New types

Selection Guide

Application reference table

Application		Tuner			IF amplifier
		Input stage	Mixer	Oscillator	
TV range	VHF	BA 243/S BA 244/S BA 282 BA 283 BA 284 BA 389 BA 682 BA 683 BB 409 BB 505 G BB 515 G			BF 199 BF 517 BF 599 BF 959
		BF 961 BF 995	BF 506 BF 961 BF 995	BF 506 BF 606 A BF 660	
	VHF (CATV/ Hyperband)	BB 609 A/B BB 610 BB 619 A/B BB 620			
		BF 964 S BF 965 BF 994 S BF 997	BF 506 BF 964 S BF 965 BF 994 S BF 997	BF 506 BF 517 BF 606 A BF 660 BF 763	
UHF	BB 505 B BB 515 B				
	BF 960 BF 966 S BF 989 BF 996 S	BF 579 BF 775 BF 979 S	BF 569 BF 970 BF 569 BF 970		
TV-sat	Indoor unit	BA 389 BA 885			
		BB 801 BF 775			BF 770 A

continued on next page

cont'd

Application		Tuner			IF amplifier
		Input stage	Mixer	Oscillator	
Radio range	AM	BB 112			
	FM	BB 204 BB 304 BB 314 BB 804 BB 814			
		BF 255 BF 414 BF 961 BF 963 BF 993 BF 995	BF 241 BF 255 BF 451 BF 995	BF 241 BF 255 BF 451	BF 240 BF 241 BF 254 BF 255 BF 450 BF 451

Selection Guide

Cross reference table of packages

Application	Package	Conventional mounting				Surface mounting (SMD)			
		TO 92	T-plast	X-plast	DO 35	SOT 23	SOT 143	SOD 80	Mini-plast
1. Switching PIN diodes									
<ul style="list-style-type: none"> VHF band switching Current-controlled RF resistor, TV-sat antenna switch 				BA 243/S BA 244/S BA 282 BA 283 BA 284 BA 389	BA 885			BA 682 BA 683	
2. Tuning diodes									
<ul style="list-style-type: none"> AM FM Extended FM band VHF VHF (Hyperband) UHF/VHF UHF/TV-sat 	BB 112 BB 204 BB 304 BB 314			BB 409 BB 609A/B BB 610 BB 505B/G	BB 804 BB 814				BB 619A/B BB 620 BB 515B/G
3. Bipolar transistors									
<ul style="list-style-type: none"> TV IF AM, FM IF stage (AM, FM) VHF oscillator RF amplifier/oscillator SAW filter driver UHF mixer/oscillator TV-sat 	BF 199 BF 254 BF 255 BF 414 BF 450 BF 451 BF 240 BF 241 BF 506 BF 606 A BF 763 BF 959	BF 970 BF 979 S			BF 599 BF 554 BF 660 BF 550 BF 660 BF 660 BF 517 BF 799 BF 569 BF 579 BF 775 BF 770 A				
4. MOSFET tetrodes									
<ul style="list-style-type: none"> UHF preamplifier VHF FM input stage/mixer 			BF 960 BF 966 S BF 961 BF 963 BF 964 S BF 965					BF 989 BF 996 S BF 995 BF 993 BF 994 S BF 997	

Types and ordering codes
(in alphanumerical order)

Type	Ordering code	Page	Type	Ordering code	Page
BA 243	Q62702-A521	30	BF 254	Q62702-F201	89
BA 243 S	Q62702-A607	32	BF 255	Q62702-F329	89
BA 244	Q62702-A421	30	BF 414	Q62702-F517	92
BA 244 S	Q62702-A618	32	BF 450	Q62702-F312	94
BA 282	Q62702-A428	34	BF 451	Q62702-F313	94
BA 283	Q62702-A429	34	BF 506	Q62702-F534	99
BA 284	Q62702-A632	36	BF 517	Q62702-F988	101
BA 389	Q62702-A732	38	BF 550	Q62702-F547	104
BA 682	Q62702-A723	41	BF 554	Q62702-F551	109
BA 683	Q62702-A145	41	BF 569	Q62702-F548	113
BA 885	Q62702-A742	44	BF 579	Q62702-F552	116
BB 112	Q62702-B240	46	BF 599	Q62702-F550	119
BB 204 blue	Q62702-B58-X6	49	BF 606 A	Q62702-F535	123
BB 204 green	Q62702-B57-X5	49	BF 660	Q62702-F549	125
BB 304	Q62702-B84	52	BF 763	Q62702-F766	128
BB 314	Q62702-B397	55	BF 770 A	Q62702-F1068	130
BB 409	Q62702-B112	57	BF 775	Q62702-F991	133
BB 505 B	Q62702-B37	60	BF 799	Q62702-F788	136
BB 505 G	Q62702-B270	60	BF 959	Q62702-F640	139
BB 515 B	Q62702-B398	63	BF 960	Q62702-F499	142
BB 515 G	Q62702-B399	63	BF 961	Q62702-F518	152
BB 609 A	Q62702-B196	65	BF 963	Q62702-F904	162
BB 609 B	Q62702-B197	65	BF 964 S	Q62702-F446	168
BB 610	Q62702-B400	67	BF 965	Q62702-F660	174
BB 619 A	Q62702-B401	69	BF 966 S	Q62702-F438	180
BB 619 B	Q62702-B402	69	BF 970	Q62702-F650	187
BB 620	Q62702-B403	71	BF 979 S	Q62702-F610	189
BB 801	Q62702-B346	73	BF 989	Q62702-F874	191
BB 804	Q62702-B328	75	BF 993	Q62702-F899	201
BB 814	Q62702-B404	78	BF 994 S	Q62702-F963	208
BF 199	Q62702-F355	82	BF 995	Q62702-F872	214
BF 240	Q62702-F302	86	BF 996 S	Q62702-F964	224
BF 241	Q62702-F303	86	BF 997	Q62702-F993	232

 = SMD surface mounted device

**Explanation of Data Sheet Parameters
Quality Specifications**



Explanation of Data Sheet Parameters

Maximum ratings

The maximum ratings specified are absolute ratings which, if exceeded, may result in the destruction or permanent functional impairment of the components. When testing the component, as for example with respect to breakdown voltage, or during application, protection has to be provided in order to reliably ensure that maximum ratings are not exceeded.

Characteristics

Typical characteristics describe the component behavior under defined operating conditions. The numerical values and diagrams pertain to the component type and are not to be considered as characteristics of an individual component. The minimum and maximum ratings stated for reasons of important quality and application requirements describe the actual spread of the characteristics, whereas spread curves in the diagrams specify the general spread range to be expected. Electrical values are grouped into "static" DC values and "dynamic" AC values.

The **thermal resistance** is closely related to the maximum ratings and, as the upper spread value, is given immediately after the maximum ratings.

The component **package data** is defined by reference to standards sheets and dimensional drawings. Not being a typical component feature, the form of packing is mentioned in the data sheets only in special cases (e.g. if the ordering code varies with the form of packing).

Delivery quality

In this data book the delivery quality is described by technical data, such as maximum ratings and minimum and maximum characteristics.

Acceptable quality level (AQL)

In order to determine the acceptable quality level of delivery lots, the sample tests of attributes are based on AQL values. The testing of attributes is performed in accordance with the single sampling plan for normal inspection, inspection level II, DIN 40080, IEC 410, MIL-STD-105D respectively.

Classification of defects

A defect exists if a component characteristic does not fulfil the value given in the data sheet. Defects are classified according to type and degree of seriousness.

Types of defects

- Damage to package and connections
- Electrical defects

Degree of defects

- A defect exists if a data sheet value exceeds the specified range.
- Inoperatives are components whose functional use as per data sheet is impossible.

AQL table

Type of defect	AQL value
Inoperatives (mechanical and electrical)	0.1
Σ Defects in DC parameters	0.4
Defects in AC parameters	1.5
Σ Damage to package and connections	0.4

AQL values do not describe the actual quality of individual delivery lots, but rather serve to determine — on the basis of the sampling plans — their acceptance or rejection.

As a rule, the average percentage of defectives in shipments is lower than the AQL values.

**Packaging
Mounting Instructions**



Packaging

Each packaging unit of regular deliveries has information stamped on it such as the name of the manufacturer, type, quantity, date and place of manufacture, lot identification, ESD sensitivity, matching, etc. These details, which are binding for the contents, identify in un-coded form those types in particular whose size do not permit them to have many details stamped on them and they are important for reporting back if there should ever be any complaints.

Bulk is the general loose form of packaging that enables components to be removed singly, but appropriate stations are needed to direct their supply for automatic placement. This is the normal form of packaging, especially for T-plast and X-plast devices. Taping is available in standardized versions for TO 92 and SMD packages, in the case of diodes with axial leads (DO 35) it is the normal form of packaging.

Below the current forms of taping are summarized. Please inquire for details of dimensional tolerances or variations in how the components are oriented.

Taping: TO 92 package

(Taping of components with radial leads)

The components are held at one end. The position of the flat side of the package, and thus the orientation of the leads, in the direction in which the tape unreels (see drawings) should be noted. The tape dimensions conform to DIN IEC proposed standards. The leads are kinked for an in-line spacing of 200 mil, corresponding to 5 mm (between outer leads). The tape is supplied with 1500 units on reels (octagonal shape) with a layer of paper in between and corrugated cardboard covering; fanfolded tape ("AMMO pack") is available with 1000 units/carton (E 6325 as additional identification to the type designation).

Additional identification to type designation

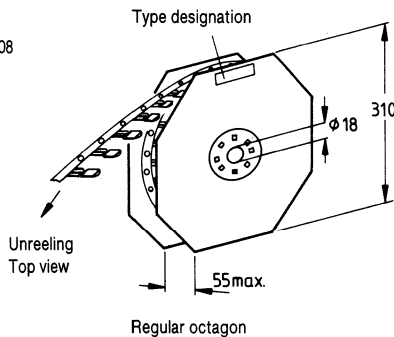
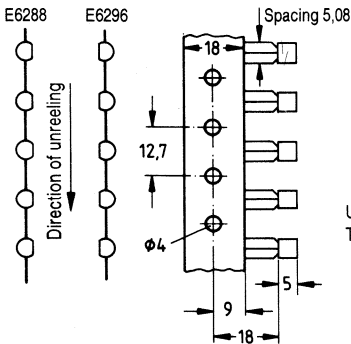

Dimensions in mm

Taping: DO 35 package

(Taping of components with axial leads)

The standard form is a twin tape wound on octagonal cardboard or plastic reels according to DIN IEC 52.133, EIA RS 481 with a maximum complement of 15000 pieces/reel.

Fanfolding of the tape in a carton (AMMO pack) is only used for small sample quantities or by special arrangement; likewise the inclusion of a protective paper layer between the tape layers must be specially contracted for.

The diodes are taped according to polarity; the colored (usually red) adhesive tape marks the cathode end and the white adhesive tape the anode end.

Groups of matched units that should not be mixed (e.g. as in the case of diodes sorted for capacitance tracking) are separated by six empty spaces. The reel is held by a layer of corrugated cardboard.

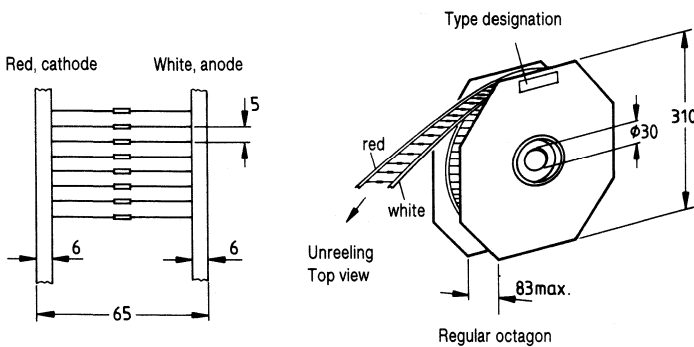

Dimensions in mm

Packaging

Taping: SMD packages (SOT 23, SOT 143, SOD 80, mini-plast)

The components are inserted in cavities of the 8-mm metal or embossed plastic tape oriented in one direction and held by removable fixing tape. The center of the component compartment is perforated. The tape is wound with 3000 (SOD 80: 2500) components on a reel diameter of 18 cm or with 10000 (SOD 80: 7500) components on a reel diameter of 33 cm. The reels are placed in plastic boxes.

This form of packaging conforms to DIN IEC 286-3.

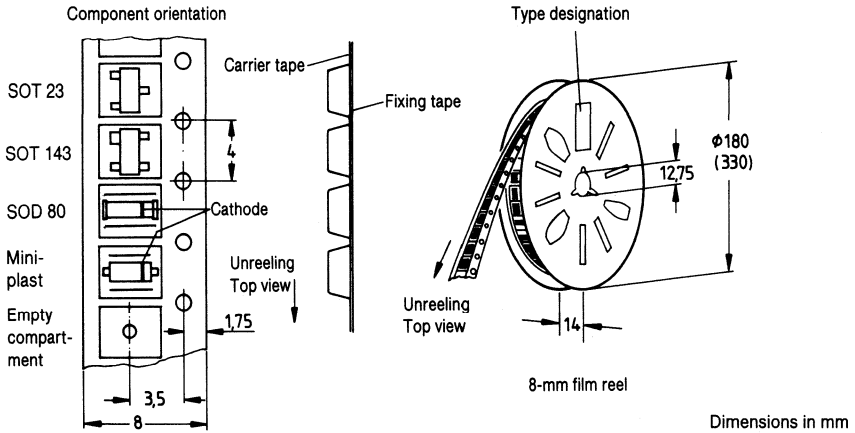

ESD-sensitive components

ESD-sensitive¹⁾ components are supplied in anti-static packaging. The attached warning label calls your attention to the necessity of protecting the components against electrostatic discharge, beginning with the opening of the package.

Heat dissipation

The heat caused by the power loss in the active semiconductor region during operation must be dissipated by appropriate circuit layout: in the case of small-signal types described here, the PC board plays the primary role in dissipating and distributing the heat.

The maximum values of thermal resistance R_{thJA} given in the data sheets are determined for T-plast, X-plast, TO 92 and diodes with reference to ambient air with only slight heat dissipation through the leads; they can quite easily be taken for the usual mounting methods.

The R_{th} of SMDs, e.g. SOT 23 and SOT 143, is also measured with reference to ambient air on ceramic test substrates (see illustration). For mounting SMDs on PC boards the higher thermal resistance (by approx. 90 K/W) has to be considered.

Al₂O₃ test substrate, metallization

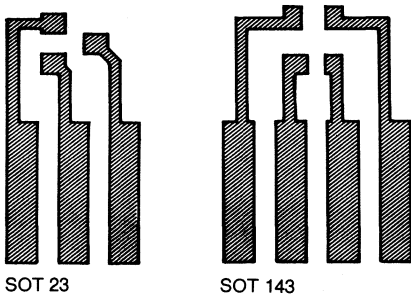

Ceramic dimensions: 16,7 mm × 15 mm × 0,7 mm

Thermal resistance SOT 23, SOT 143

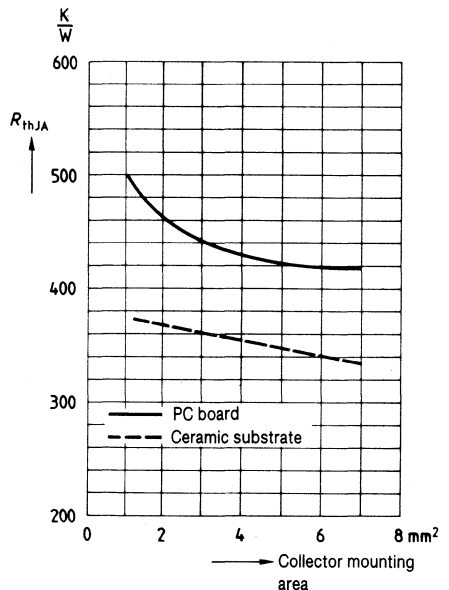

¹⁾ ESD = electrostatic discharge

Mounting Instructions

Mechanical stress

During circuit assembly it has to be ensured that the components are not subjected to mechanical stress. The anchoring of the leads in the package is especially endangered, and if it is loosened, a component may very well fail.

- Bending of the leads requires mechanical relief between the point of bending and the package. Bending directly at the package perpendicular to the plane of the lead frame is admissible with T-plast and X-plast (if it is done gently).
- Band-shaped leads (e.g. with T-plast) are not to be bent in the lead frame plane.
- Repeated bending in the same place is not permissible.

Soldering

Before starting the soldering, make sure the component is attached to the PC board in a fashion which does not exert undue mechanical stress on the leads. The adhesives that are used for wave soldering of SMDs must be neutral in their chemical and electrical reaction.

Components should not be subjected to excessive temperature/time stresses during soldering. The following tables provide the guidelines.

Recommended maximum soldering time for DO 35

Free lead length	1.5	2.5	5	mm
Soldering temperature 245 °C	4	6	13	s
Soldering temperature 260 °C	3.5	4	10	s
Iron soldering 300 °C	3	3.5	8	s

Recommended maximum soldering time for T-plast, X-plast, TO 92

Free lead length	0.5	1.5	5	mm
Soldering temperature 245 °C	4	5	10	s
Soldering temperature 260 °C	3	5	5	s
Iron soldering 300 °C	2.5	3	5	s

Recommended maximum soldering time for SMDs

Wave soldering 260 °C, 8 s

Diodes



- For VHF band switching in TV tuners

DO 35 DHD

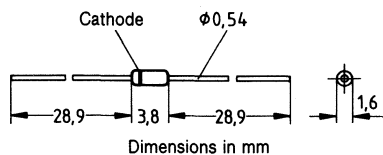

Type	BA 243	BA 244
Ordering code	Q62702-A521	Q62702-A421
Color	yellow	

Maximum ratings

Reverse voltage	V_R	35	V
Forward current	I_F	100	mA
$T_A \leq 60^\circ\text{C}$			
Junction temperature	T_j	150	$^\circ\text{C}$
Storage temperature range	T_{stg}	-55... + 150	$^\circ\text{C}$

Thermal resistance

Junction — ambient	R_{thJA}	≤ 400	K/W
--------------------	------------	------------	-----

Characteristics ($T_A = 25^\circ\text{C}$)

		min	typ	max	
Forward voltage $I_F = 100\text{ mA}$	V_F	—	—	1	V
Reverse current $V_R = 15\text{ V}$	I_R	—	—	50	nA
Diode capacitance $V_R = 15\text{ V}, f = 1\text{ MHz}$	C_T	—	1,3	2	pF
Forward resistance $I_F = 10\text{ mA}, f = 100\text{ MHz}$	r_f				
BA 243		—	0,5	1	Ω
BA 244		—	0,4	0,5	Ω
Reverse resistance $V_R = 1\text{ V}, f = 100\text{ MHz}$	$1/g_p$	—	100	—	k Ω
Series inductance	L_s	—	2,5	—	nH

- For VHF band switching in TV tuners
- Low forward resistance and low diode capacitance

DO 35 DHD

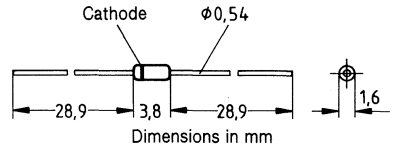

Type	BA 243 S	BA 244 S
Ordering code	Q62702-A607	Q62702-A618
Color	yellow	

Maximum ratings

Reverse voltage	V_R	35	V
Forward current	I_F	100	mA
$T_A \leq 60^\circ\text{C}$			
Junction temperature	T_j	150	$^\circ\text{C}$
Storage temperature range	T_{stg}	-55... + 150	$^\circ\text{C}$

Thermal resistance

Junction — ambient	R_{thJA}	≤ 400	K/W
--------------------	------------	------------	-----

Characteristics ($T_A = 25^\circ\text{C}$)

		min	typ	max	
Forward voltage $I_F = 100\text{ mA}$	V_F	—	—	1	V
Reverse current $V_R = 15\text{ V}$	I_R	—	—	50	nA
Diode capacitance, $f = 1\text{ MHz}$ $V_R = 15\text{ V}$	C_T	—	1,3	—	pF
5 V		—	—	1,5	pF
1 V		—	1,85	—	pF
Forward resistance, $f = 100\text{ MHz}$	r_f				
BA 243 S: $I_F = 10\text{ mA}$		—	—	0,7	Ω
2 mA		—	—	2	Ω
BA 244 S: $I_F = 10\text{ mA}$		—	—	0,5	Ω
2 mA		—	1	—	Ω
Reverse resistance $V_R = 1\text{ V}$, $f = 100\text{ MHz}$	$1/g_p$	—	100	—	k Ω
Series inductance	L_s	—	2,5	—	nH

- Low-loss VHF band switch for TV tuners

DO 35 DHD

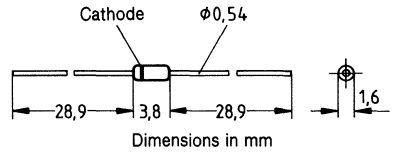

Type	BA 282	BA 283
Ordering code	Q62702-A428	Q62702-A429
Color	yellow	

Maximum ratings

Reverse voltage	V_R	35	V
Forward current	I_F	100	mA
$T_A \leq 60^\circ\text{C}$			
Junction temperature	T_j	150	$^\circ\text{C}$
Storage temperature range	T_{stg}	-55...+150	$^\circ\text{C}$

Thermal resistance

Junction — ambient	R_{thJA}	≤ 400	K/W
--------------------	------------	------------	-----

Characteristics ($T_A = 25\text{ }^\circ\text{C}$)

		min	typ	max	
Forward voltage $I_F = 100\text{ mA}$	V_F	—	—	1	V
Reverse current $V_R = 20\text{ V}$	I_R	—	—	50	nA
Diode capacitance, $f = 1\text{ MHz}$ BA 282: $V_R = 1\text{ V}$ 3 V BA 283: $V_R = 1\text{ V}$ 3 V	C_T	— — — —	— — — —	1,5 1,2 1,5 1	pF pF pF pF
Forward resistance, $f = 100\text{ MHz}$ BA 282: $I_F = 3\text{ mA}$ 10 mA BA 283: $I_F = 3\text{ mA}$ 10 mA	r_f	— — — —	— — — —	0,7 0,5 1,2 0,9	Ω Ω Ω Ω
Reverse resistance $V_R = 1\text{ V}$, $f = 100\text{ MHz}$	$1/g_p$	—	100	—	k Ω
Series inductance	L_s	—	2,5	—	nH

- Low-loss RF switch for use at frequencies above 10 MHz, especially in TV tuners

DO 35 DHD

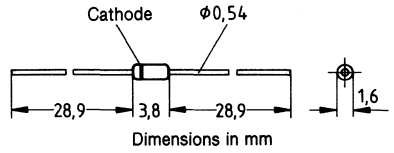

Type	BA 284
Ordering code	Q62702-A632
Color	yellow

Maximum ratings

Reverse voltage

V_R	35	V
I_F	100	mA

Forward current

$T_A \leq 60^\circ\text{C}$

Junction temperature

T_j	150	$^\circ\text{C}$
T_{stg}	-65... +150	$^\circ\text{C}$

Storage temperature range

Thermal resistance

Junction — ambient

R_{thJA}	≤ 400	K/W
------------	------------	-----

Characteristics ($T_A = 25^\circ\text{C}$)

		min	typ	max	
Forward voltage $I_F = 100\text{ mA}$	V_F	—	—	1	V
Reverse current $V_R = 20\text{ V}$	I_R	—	—	50	nA
Diode capacitance, $f = 1\text{ MHz}$ $V_R = 1\text{ V}$ 20 V	C_T	—	1 0,8	— 1	pF pF
Forward resistance, $f = 100\text{ MHz}$ $I_F = 3\text{ mA}$ 10 mA	r_f	—	0,75 0,45	— 0,6	Ω Ω
Reverse resistance, $V_R = 1\text{ V}$ $f = 1\text{ MHz}$ 100 MHz	$1/g_p$	1	— 100	— —	M Ω k Ω
Series inductance	L_s	—	2,5	—	nH

- Current-controlled RF resistor for switching and attenuation applications
- Frequency range
1 MHz ... 1 GHz

DO 35 DHD

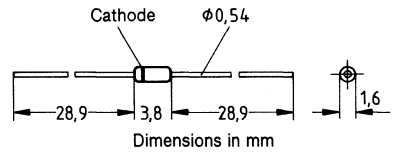

Type	BA 389
Ordering code	Q62702-A732
Color	yellow

Maximum ratings

Reverse voltage	V_R	30	V
Forward current	I_F	50	mA
Junction temperature	T_j	150	°C
Storage temperature range	T_{stg}	-65... +150	°C

Thermal resistance

Junction — ambient	R_{thJA}	≤ 400	K/W
--------------------	------------	-------	-----

Characteristics ($T_A = 25^\circ\text{C}$)

		min	typ	max	
Forward voltage $I_F = 50\text{ mA}$	V_F	—	—	1	V
Reverse current $V_R = 30\text{ V}$	I_R	—	—	50	nA
Diode capacitance $V_R = 10\text{ V}, f = 1\text{ MHz}$ $0\text{ V}, 100\text{ MHz}$	C_T	—	0,55	—	pF
		—	0,35	0,5	pF
Forward resistance, $f = 100\text{ MHz}$ $I_F = 1,5\text{ mA}$ 10 mA	r_f	—	25	40	Ω
		—	5	7,5	Ω
Zero bias conductance $V_R = 0\text{ V}, f = 100\text{ MHz}$	g_p	—	70	—	μS
Series inductance	L_s	—	2,5	—	nH

Forward characteristic $I_F = f(V_F)$

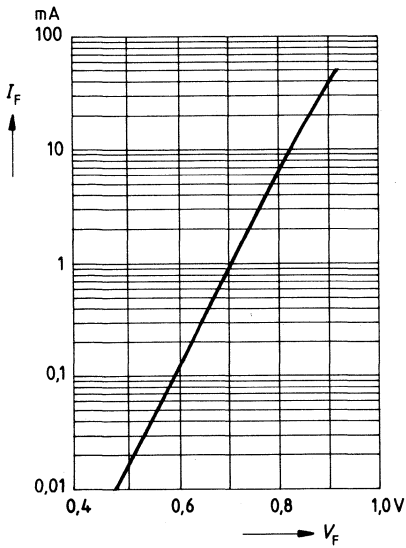

Parallel conductance $g_p = f(V_R)$

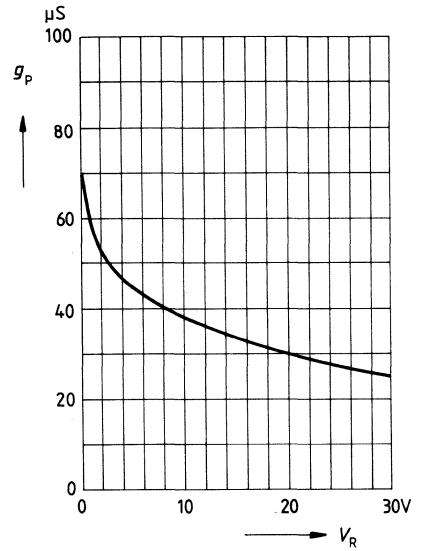

Forward resistance $r_f = f(I_F)$

$f = 100 \text{ MHz}$

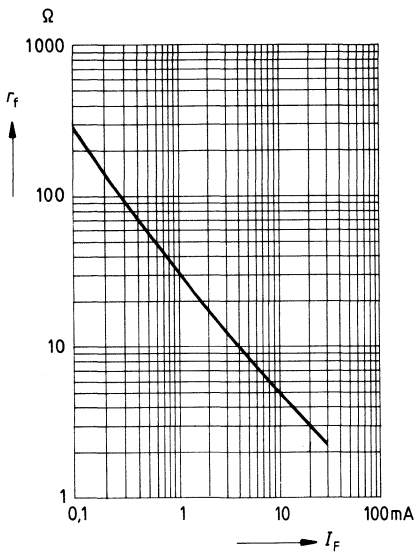

Diode capacitance $C_T = f(V_R)$

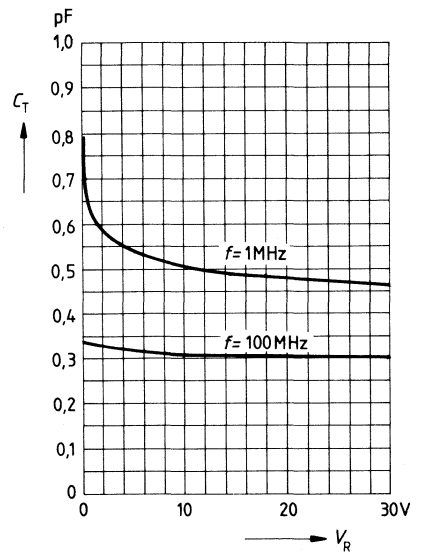

Preliminary data

- Low-loss VHF band switches in TV tuners
- Miniature glass case for surface mounting (SMD)

SOD 80

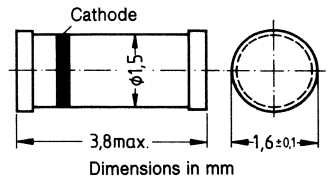

Type ¹⁾	BA 682	BA 683
Ordering code	taped: Q62702-A723	taped: Q62702-A145

Maximum ratings

Reverse voltage	V_R	35	V
Forward current	I_F	50	mA
Operating temperature	T_{op}	100	°C
Storage temperature range	T_{stg}	-55... +150	°C

Thermal resistance

Junction — ambient	R_{thJA}	≤ 400	K/W
--------------------	------------	-------	-----

¹⁾ The type designation is printed on the package label.

Characteristics ($T_A = 25^\circ\text{C}$)

		min	typ	max	
Forward voltage $I_F = 50\text{ mA}$	V_F	—	—	1	V
Reverse current $V_R = 20\text{ V}$	I_R	—	—	50	nA
Diode capacitance, $f = 1\text{ MHz}$	C_T				
BA 682: $V_R = 1\text{ V}$		—	—	1,5	pF
3 V		—	—	1,2	pF
BA 683: $V_R = 1\text{ V}$		—	—	1,5	pF
3 V		—	—	1,0	pF
Forward resistance, $f = 100\text{ MHz}$	r_f				
BA 682: $I_F = 3\text{ mA}$		—	—	0,7	Ω
10 mA		—	—	0,5	Ω
BA 683: $I_F = 3\text{ mA}$		—	—	1,2	Ω
10 mA		—	—	0,9	Ω
Reverse resistance $V_R = 1\text{ V}$, $f = 100\text{ MHz}$	$1/g_p$	—	100	—	k Ω
Series inductance	L_s	—	2	—	nH

Forward current $I_F = f(V_F)$

$T_A = 25^\circ\text{C}$

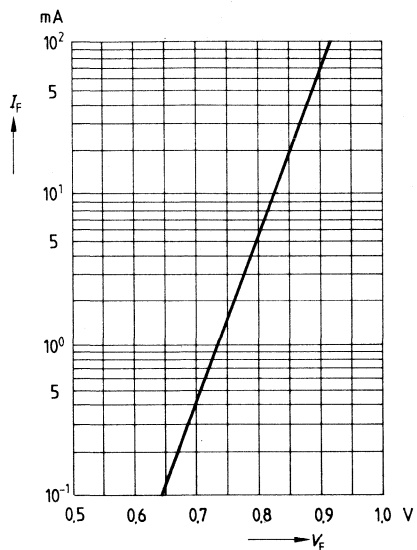

Diode capacitance $C_T = f(V_R)$

$f = 1\text{ MHz}$

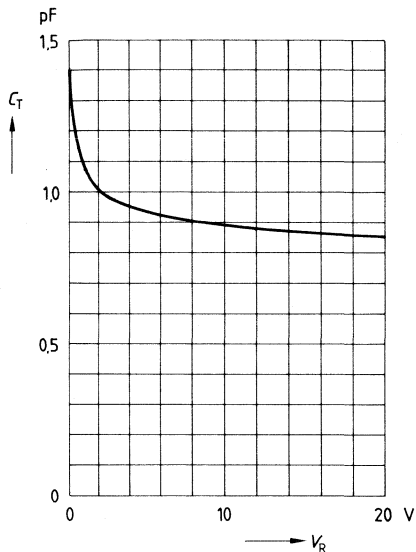

Forward resistance $r_f = f(I_F)$

$f = 100\text{ MHz}$

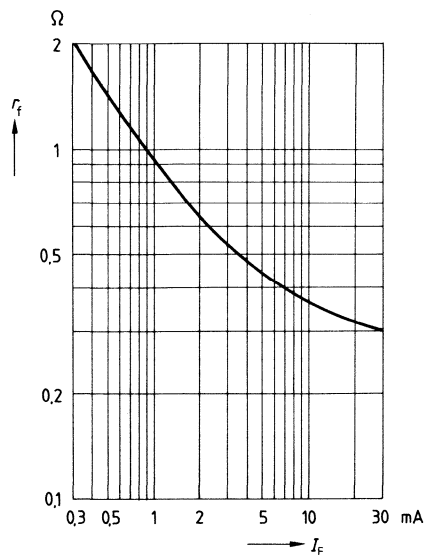

- Current-controlled RF resistor
- Frequency range:
1 MHz ... 2 GHz
- Designed for antenna switching
in TV-sat tuners
- Miniature plastic package
for surface mounting (SMD)

SOT 23

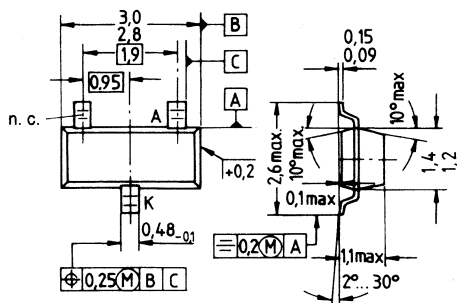

Dimensions in mm

Type	BA 885	
Ordering code	bulk: Q62702-A742	taped: Q62702-A608
Marking	PA	

Maximum ratings

Reverse voltage	V_R	50	V
Forward current	I_F	50	mA
Operating temperature	T_{op}	100	°C
Storage temperature range	T_{stg}	- 65... + 150	°C

Thermal resistance

Junction — ambient	R_{thJA}	≤ 450	K/W ¹⁾
--------------------	------------	-------	-------------------

¹⁾ Package mounted on alumina 16.7 mm × 15 mm × 0.7 mm.

Characteristics ($T_A = 25^\circ\text{C}$)

		min	typ	max	
Forward voltage $I_F = 50\text{ mA}$	V_F	—	—	1,1	V
Reverse current $V_R = 30\text{ V}$	I_R	—	—	50	nA
Diode capacitance $V_R = 10\text{ V}, f = 1\text{ MHz}$ $0\text{ V}, 100\text{ MHz}$	C_T		0,3 0,23	— 0,5	pF pF
Forward resistance, $f = 100\text{ MHz}$ $I_F = 1,5\text{ mA}$ 10 mA	r_f	— —	22 5	40 7	Ω Ω
Zero bias conductance $V_R = 0, f = 100\text{ MHz}$	g_p	—	70	—	μS

Diode capacitance $C_T = f(V_R)$
 $f = 1\text{ MHz}/100\text{ MHz}$

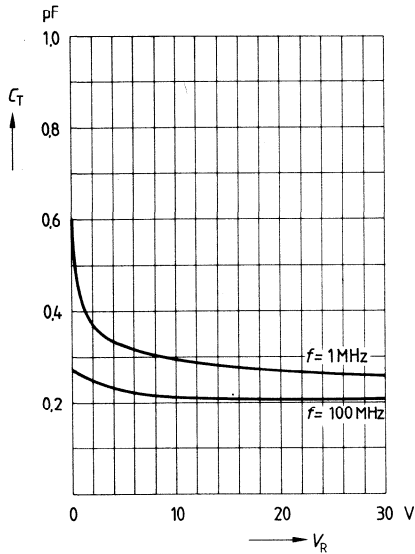

Forward resistance $r_f = f(I_F)$
 $f = 100\text{ MHz}$

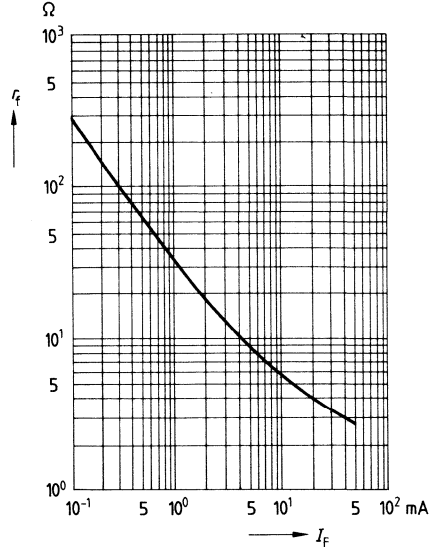

- For AM tuning applications
- Specified tuning range
1...8.5 V

TO 92

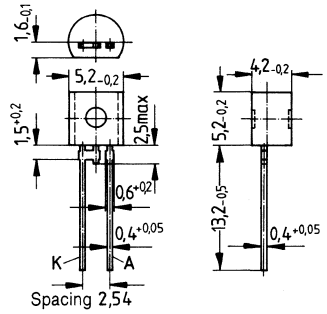

Dimensions in mm

Type	BB 112
Ordering code	Q62702-B240

Maximum ratings

Reverse voltage	V_R	12	V
Forward current	I_F	50	mA
$T_A \leq 60^\circ\text{C}$			
Operating temperature range	T_{op}	-55...+ 85	$^\circ\text{C}$

Characteristics ($T_A = 25\text{ }^\circ\text{C}$)**DC characteristics**

		min	typ	max	
Reverse current	I_R	—	—	50	nA
$V_R = 10\text{ V}$		—	—	200	nA
$10\text{ V}, T_A = 60\text{ }^\circ\text{C}$		—	—		

AC characteristics

Diode capacitance, $f = 1\text{ MHz}$	C_T				
$V_R = 1\text{ V}$		440	470	520	pF
$8,5\text{ V}$		16,5	—	29	pF
Capacitance ratio	$\frac{C_T 1}{C_T 8,5}$	18	—	—	—
$V_R = 1\text{ V}/8,5\text{ V}$					
Series resistance	r_s	—	1,4	—	Ω
$V_R = 1\text{ V}, f = 0,5\text{ MHz}$					
Q factor	Q	—	480	—	—
$V_R = 1\text{ V}, f = 0,5\text{ MHz}$					
Temperature coefficient of diode capacitance	TC_C	—	500	—	ppm/K
$V_R = 1\text{ V}, f = 1\text{ MHz}$					
Capacitance matching	$\frac{\Delta C_T}{C_T}$	—	—	3	%
$V_R = 1 \dots 8,5\text{ V}$					

Diode capacitance $C_T = f(V_R)$

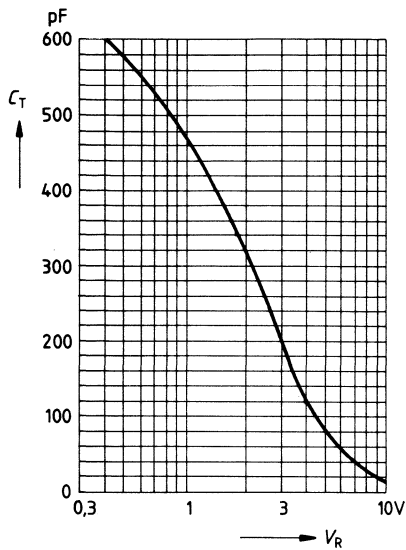

Capacitance ratio $C_T/C_{Tref} = f(V_R)$

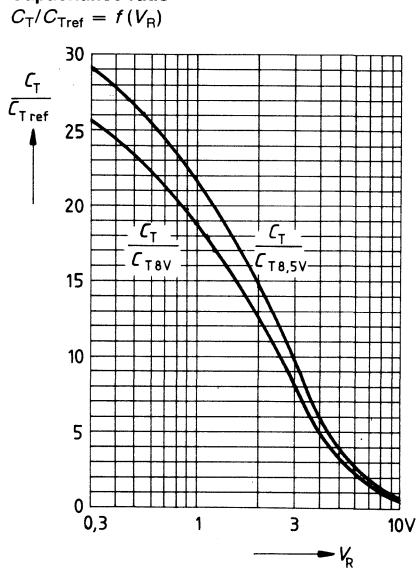

Capacitance ratio $C_T/C_{T1V} = f(V_R)$

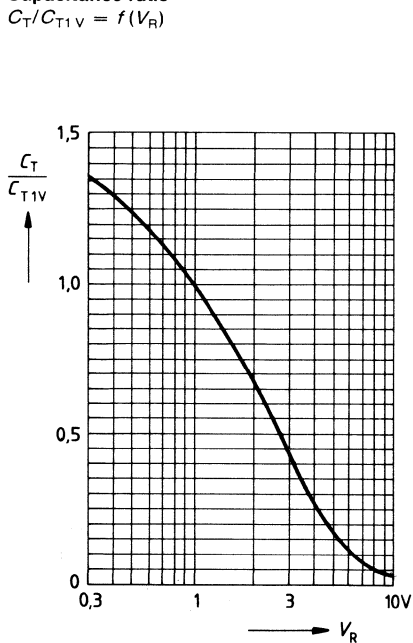

Temperature coefficient of junction capacitance $TC_C = f(V_R)$

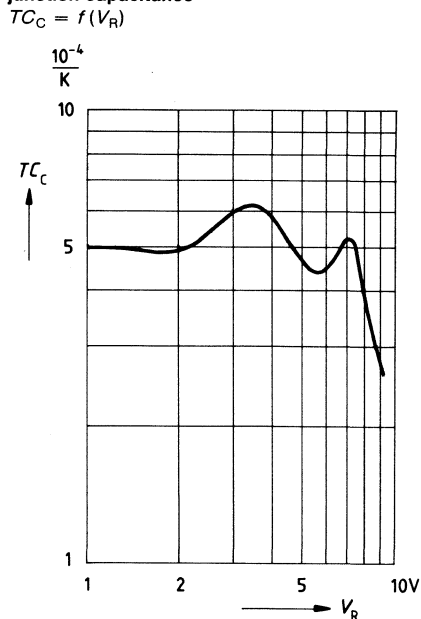

- For FM tuners
- Monolithic chip with common cathode for perfect tracking of both diodes
- Uniform “square law” characteristics
- Ideal Hifi tuning device when used in low-distortion, back-to-back configuration
- Capacitance subgroups available

TO 92

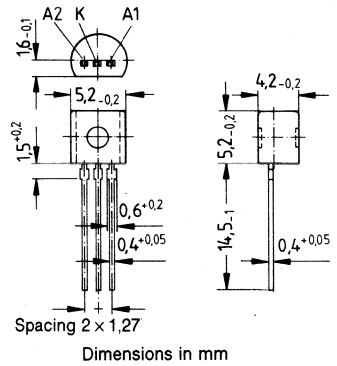

Type	BB 204	
Ordering code	Q62702-B58-X6	Q62702-B57-X5
Color	blue	green

Maximum ratings per diode

Reverse voltage	V_R	30	V
Peak reverse voltage	V_{RM}	32	V
Forward current	I_F	50	mA
$T_A \leq 60^\circ C$			
Storage temperature range	T_{stg}	-55... +100	$^\circ C$

Characteristics per diode ($T_A = 25\text{ }^\circ\text{C}$)**DC characteristics**

		min	typ	max	
Breakdown voltage $I_R = 10\text{ }\mu\text{A}$	$V_{(BR)}$	32	—	—	V
Reverse current $V_R = 30\text{ V}$ $30\text{ V}, T_A = 60\text{ }^\circ\text{C}$	I_R	—	—	20	nA
		—	—	0,2	μA

AC characteristics

Diode capacitance, $f = 1\text{ MHz}$ $V_R = 3\text{ V}$, green 3 V , blue $V_R = 30\text{ V}$, green 30 V , blue	C_T	34 37 — —	— — 13,7 14,4	39 42 — —	pF pF pF pF
Capacitance ratio, $f = 1\text{ MHz}$ $V_R = 3\text{ V}, 30\text{ V}$	$\frac{C_{T3}}{C_{T30}}$	2,55	2,7	2,8	—
Series resistance $C_T = 38\text{ pF}, f = 100\text{ MHz}$	r_s	—	0,2	0,4	Ω
Q factor $C_T = 38\text{ pF}, f = 100\text{ MHz}$	Q	100	200	—	—
Temperature coefficient of diode capacitance $V_R = 3\text{ V}, f = 1\text{ MHz}$	TC_C	—	300	—	ppm/K

Diode capacitance $C_T = f(V_R)$

per diode, $f = 1 \text{ MHz}$

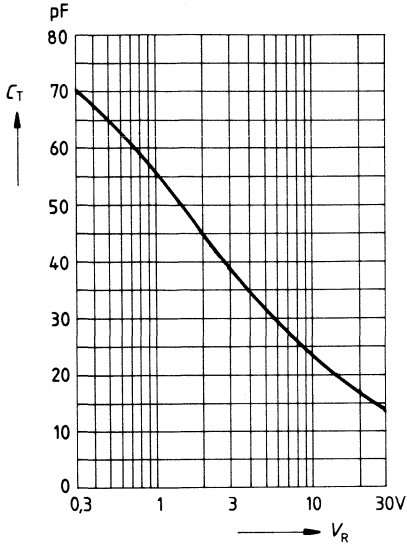

Capacitance ratio $C_{Tref}/C_t = f(V_R)$

per diode; $V_{ref} = 1 \text{ V}, 2 \text{ V}, 3 \text{ V}; f = 1 \text{ MHz}$

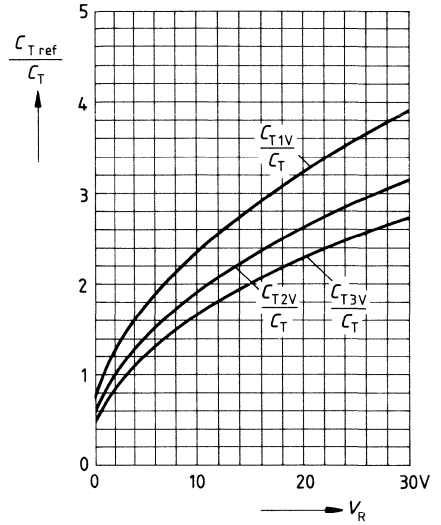

Temperature coefficient of diode capacitance $TC_C = f(V_R)$

per diode, $f = 1 \text{ MHz}$

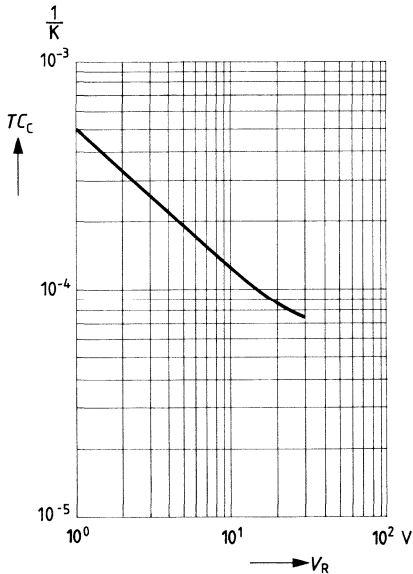

- For FM tuners
- Monolithic chip with common cathode for perfect tracking of both diodes
- Uniform "square law" characteristics
- Ideal Hifi tuning device when used in low-distortion, back-to-back configuration
- Color-coded capacitance subgroups available (see next page)

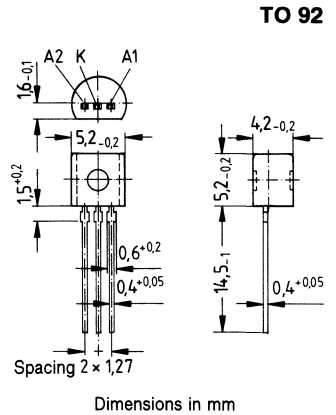

Type	BB 304
Ordering code	Q62702-B84

Maximum ratings per diode

Reverse voltage	V_R	30	V
Peak reverse voltage	V_{RM}	32	V
Forward current	I_F	50	mA
$T_A \leq 60^\circ\text{C}$			
Storage temperature range	T_{stg}	- 55... + 100	$^\circ\text{C}$

Characteristics per diode ($T_A = 25\text{ }^\circ\text{C}$)

		min	typ	max	
Reverse current	I_R				
$V_R = 30\text{ V}$		—	—	20	nA
$30\text{ V}, T_A = 60\text{ }^\circ\text{C}$		—	—	0,2	μA
Diode capacitance	C_T	42	—	47,5	pF
$V_R = 2\text{ V}, f = 1\text{ MHz}$					
Capacitance ratio	$\frac{C_{T2}}{C_{T8}}$	1,65	—	1,75	—
$V_R = 2\text{ V}, 8\text{ V}, f = 1\text{ MHz}$					
Series resistance	r_s	—	0,2	0,4	Ω
$C_T = 38\text{ pF}, f = 100\text{ MHz}$					
Q factor	Q	100	200	—	—
$C_T = 38\text{ pF}, f = 100\text{ MHz}$					
Capacitance subgroups	C_T				
$V_R = 2\text{ V}, f = 1\text{ MHz}$					
Subgroups: red		42	—	43,5	pF
yellow		43	—	44,5	pF
white		44	—	45,5	pF
green		45	—	46,5	pF
blue		46	—	47,5	pF

Diode capacitance $C_T = f(V_R)$
per diode, $f = 1$ MHz

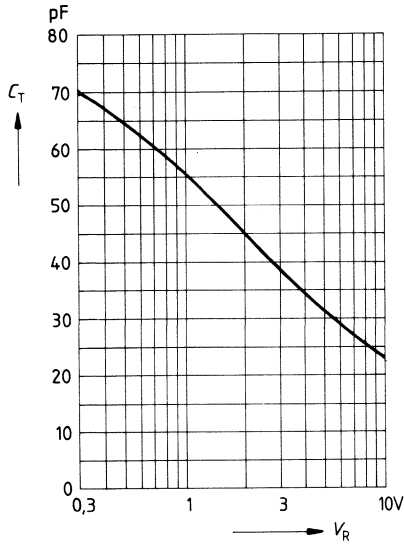

Capacitance ratio $C_{Tref}/C_T = f(V_R)$
per diode; $V_{ref} = 1$ V, 2 V; $f = 1$ MHz

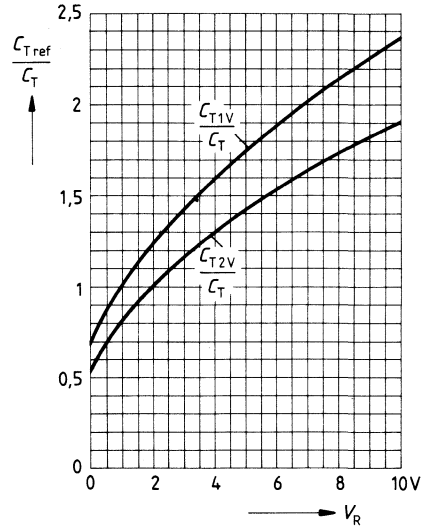

Temperature coefficient of diode capacitance $TC_C = f(V_R)$
per diode, $f = 1$ MHz

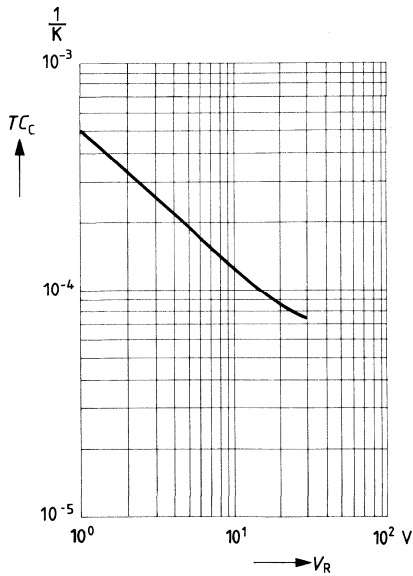

Preliminary data

- Designed for use in FM tuners with extended frequency range
- Special implantation for high capacitance ratio
- Monolithic chip for perfect tracking of both diodes; common cathode
- Capacitance subgroups available upon request

TO 92

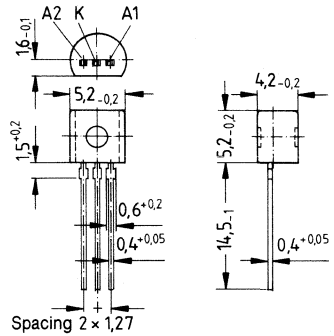

Dimensions in mm

Type	BB 314
Ordering code	Q62702-B397

Maximum ratings per diode

Reverse voltage	V_R	18	V
Peak reverse voltage	V_{RM}	20	V
Forward current	I_F	50	mA
$T_A \leq 60^\circ C$			
Storage temperature range	T_{stg}	-55... + 100	$^\circ C$

Characteristics per diode ($T_A = 25^\circ\text{C}$)

		min	typ	max	
Reverse current	I_R	—	—	20	nA
$V_R = 16\text{ V}$		—	—	0,2	μA
$16\text{ V}, T_A = 60^\circ\text{C}$					
Diode capacitance, $f = 1\text{ MHz}$	C_T	—	44,75	—	pF
$V_R = 2\text{ V}$		—	20,3	—	pF
8 V					
Capacitance ratio	$\frac{C_{T2}}{C_{T8}}$	—	2,2	—	—
$V_R = 2\text{ V}, 8\text{ V}; f = 1\text{ MHz}$	$\frac{C_{T8}}$				

Diode capacitance $C_T = f(V_R)$

per diode, $f = 1\text{ MHz}$

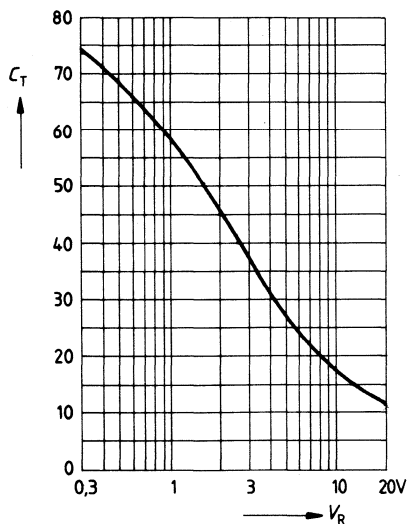

- For VHF tuners

DO 35 DHD

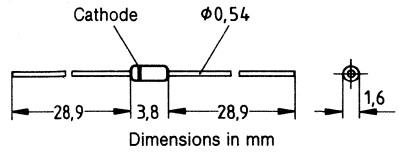

Type	BB 409
Ordering code	Q62702-B112
Color	green

Maximum ratings

Reverse voltage	V_R	28	V
Peak reverse voltage	V_{RM}	30	V
Forward current	I_F	20	mA
$T_A \leq 60^\circ\text{C}$			
Storage temperature range	T_{stg}	-55... + 150	$^\circ\text{C}$



Characteristics ($T_A = 25\text{ }^\circ\text{C}$)

		min	typ	max	
Reverse current	I_R	—	—	50	nA
$V_R = 28\text{ V}$		—	—	0,5	μA
$28\text{ V}, T_A = 60\text{ }^\circ\text{C}$		—	—	—	—
Diode capacitance, $f = 1\text{ MHz}$	C_T	26	—	32	pF
$V_R = 3\text{ V}$		4,5	—	5,6	pF
25 V		—	—	—	—
Capacitance ratio	$\frac{C_{T3}}{C_{T25}}$	5	—	6,5	—
$V_R = 3\text{ V}, 25\text{ V}; f = 1\text{ MHz}$		—	—	—	—
Capacitance matching	$\frac{\Delta C_T}{C_T}$	—	—	3	%
$V_R = 1\text{ V} \dots 28\text{ V}$		—	—	—	—
Series resistance	r_s	—	0,3	—	Ω
$C_T = 12\text{ pF}, f = 100\text{ MHz}$		—	—	—	—
Q factor	Q	—	280	—	—
$V_R = 3\text{ V}, f = 50\text{ MHz}$		—	600	—	—
$25\text{ V}, 200\text{ MHz}$		—	—	—	—
Series inductance	L_s	—	3	—	nH
Temperature coefficient of diode capacitance, $f = 1\text{ MHz}$	TC_C	—	—	—	—
$V_R = 3\text{ V}$		—	$2,5 \cdot 10^{-4}$	—	1/K
25 V		—	$0,8 \cdot 10^{-4}$	—	1/K

Reverse current $I_R = f(V_R)$

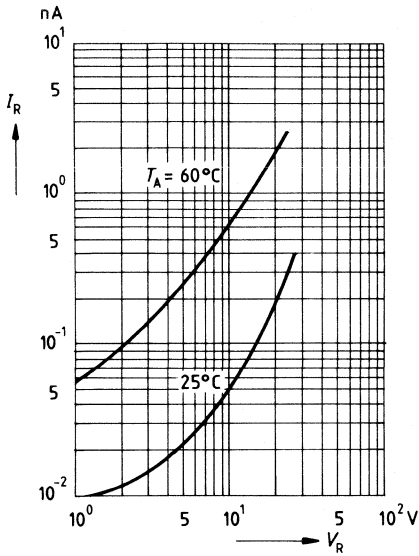

Diode capacitance $C_T = f(V_R)$

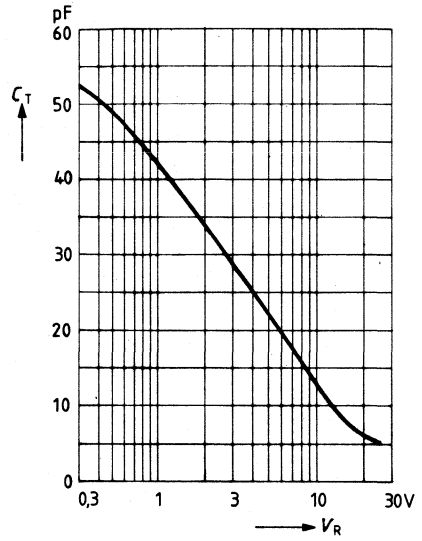

Temperature coefficient of diode capacitance $TC_C = f(V_R)$

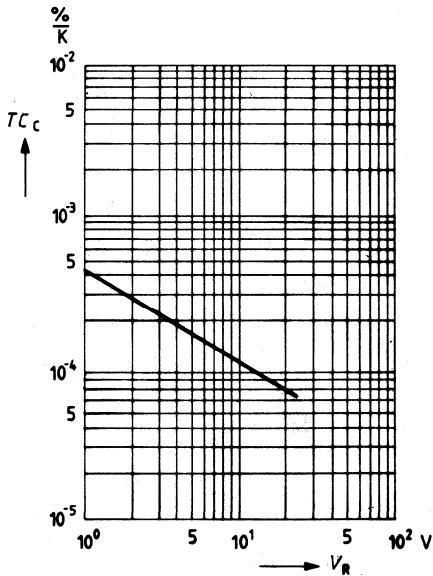

Q factor $Q = f(f)$
 $V_R = \text{Parameter}$

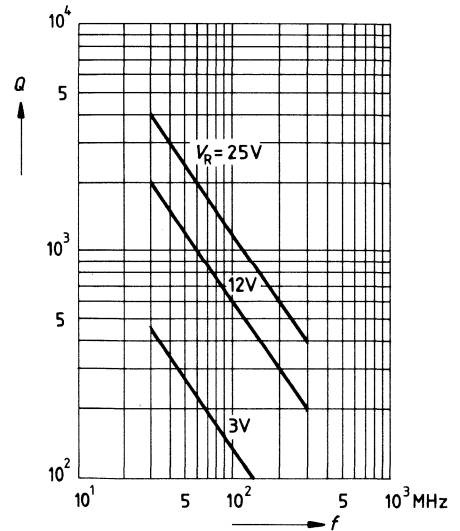

- For UHF and VHF tuners

DO 35 DHD

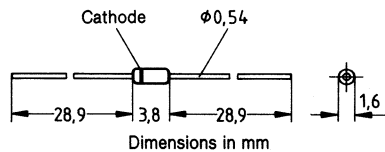

Type	BB 505 B	BB 505 G
Ordering code	Q62702-B37	Q62702-B270
Color	orange	

Maximum ratings

Reverse voltage	V_R	28	V
Peak reverse voltage	V_{RM}	30	V
Forward current	I_F	20	mA
$T_A \leq 60^\circ\text{C}$			
Operating temperature range	T_{op}	-55... +100	$^\circ\text{C}$
Storage temperature range	T_{stg}	-55... +150	$^\circ\text{C}$

Characteristics ($T_A = 25\text{ }^\circ\text{C}$)

		min	typ	max	
Reverse current	I_R				
$V_R = 28\text{ V}$		—	—	20	nA
$28\text{ V}, T_A = 60\text{ }^\circ\text{C}$		—	—	0,5	μA
Diode capacitance, $f = 1\text{ MHz}$	C_T				
BB 505 B: $V_R = 1\text{ V}$		—	17,5	—	pF
28 V		1,85	—	2,25	pF
BB 505 G: $V_R = 1\text{ V}$		—	17,5	—	pF
28 V		1,8	—	2,4	pF
Capacitance ratio	$\frac{C_{T1}}{C_{T28}}$				
$V_R = 1\text{ V}, 28\text{ V}; f = 1\text{ MHz}$					
BB 505 B		7,7	—	9,4	—
BB 505 G		7,5	—	9,5	—
Capacitance matching	$\frac{\Delta C_T}{C_T}$				
$V_R = 0,5\text{ V} \dots 28\text{ V}$		—	—	3	%
Series resistance	r_s				
$C_T = 9\text{ pF}, f = 470\text{ MHz}$					
BB 505 B		—	—	0,7	Ω
BB 505 G		—	—	1	Ω
Series inductance	L_s				
		—	3	—	nH
Temperature coefficient of diode capacitance	TC_C				
$V_R = 1\text{ V}, f = 1\text{ MHz}$		—	480	—	ppm/K

Diode capacitance $C_T = f(V_R)$

$f = 1 \text{ MHz}$

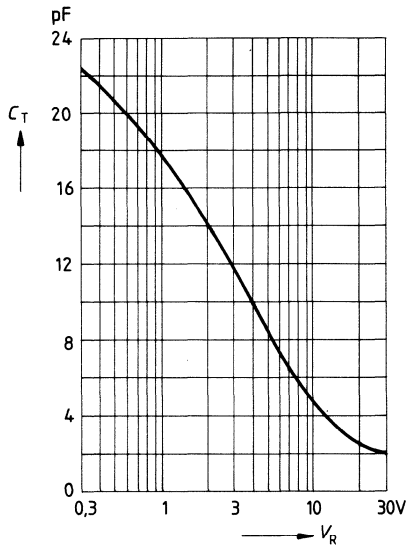

Preliminary data

- For UHF and VHF TV tuners
- Miniature plastic package for surface mounting (SMD)

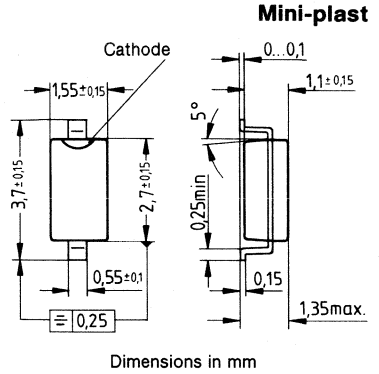

Type	BB 515 B	BB 515 G
Ordering code	Q62702-B398	Q62702-B399

Maximum ratings

Reverse voltage	V_R	28	V
Peak reverse voltage	V_{RM}	30	V
Forward current	I_F	20	mA
$T_A \leq 60^\circ\text{C}$			
Operating temperature range	T_{op}	-55...+100	$^\circ\text{C}$
Storage temperature range	T_{stg}	-55...+100	$^\circ\text{C}$

Characteristics ($T_A = 25\text{ }^\circ\text{C}$)

		min	typ	max	
Reverse current	I_R	—	—	20	nA
$V_R = 28\text{ V}$		—	—	0,2	μA
$28\text{ V}, T_A = 60\text{ }^\circ\text{C}$					
Diode capacitance, $f = 1\text{ MHz}$	C_T				
BB 515 B: $V_R = 1\text{ V}$		—	17,7	—	pF
28 V		1,85	—	2,25	pF
BB 515 G: $V_R = 1\text{ V}$		—	17,7	—	pF
28 V		1,8	—	2,4	pF
Capacitance ratio	$\frac{C_{T1}}{C_{T28}}$				
$V_R = 1\text{ V}, 28\text{ V}; f = 1\text{ MHz}$					
BB 515 B		8	—	9,5	—
BB 515 G		7,5	—	9,5	—
Capacitance matching	$\frac{\Delta C_T}{C_T}$	—	—	3	%
$V_R = 0,5\text{ V} \dots 28\text{ V}$					
Series resistance	r_s				
$C_T = 9\text{ pF}, f = 470\text{ MHz}$					
BB 515 B		—	0,55	—	Ω
BB 515 G		—	—	1	Ω
Series inductance	L_s	—	2,5	—	nH

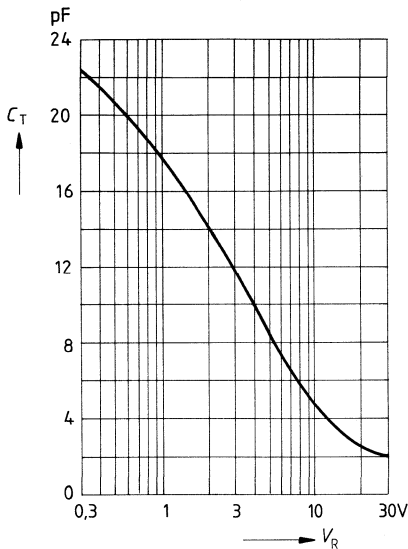

Diode capacitance $C_T = f(V_R)$
 $f = 1\text{ MHz}$

- Especially for tuning of extended frequency bands in VHF and CATV tuners

DO 35 DHD

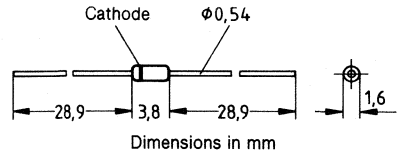

Type	BB 609 A	BB 609 B
Ordering code	Q62702-B196	Q62702-B197
Color	white	

Maximum ratings

Peak reverse voltage	V_{RM}	30	V
Forward current	I_F	20	mA
$T_A \leq 60^\circ\text{C}$			
Operating temperature range	T_{op}	-55... + 100	$^\circ\text{C}$
Storage temperature range	T_{stg}	-55... + 150	$^\circ\text{C}$

Characteristics ($T_A = 25\text{ }^\circ\text{C}$)

		min	typ	max	
Reverse current	I_R	—	—	20	nA
$V_R = 30\text{ V}$		—	—	200	nA
$30\text{ V}, T_A = 60\text{ }^\circ\text{C}$					
Diode capacitance, $f = 1\text{ MHz}$	C_T				
BB 609 A: $V_R = 1\text{ V}$		32,5	—	—	pF
28 V		2,5	—	3	pF
BB 609 B: $V_R = 1\text{ V}$		33,5	—	—	pF
28 V		2,8	—	3,2	pF
Capacitance ratio	$\frac{C_{T1}}{C_{T28}}$	12	—	15	—
$V_R = 1\text{ V}, 28\text{ V}; f = 1\text{ MHz}$					
Capacitance matching	$\frac{\Delta C_T}{C_T}$	—	—	2,5	%
$V_R = 1\text{ V} \dots 28\text{ V}, f = 1\text{ MHz}$					
Series resistance	r_s	—	0,7	1	Ω
$C_T = 12\text{ pF}, f = 100\text{ MHz}$					
Series inductance	L_s	—	3	—	nH

Diode capacitance $C_T = f(V_R)$
 $f = 1\text{ MHz}$

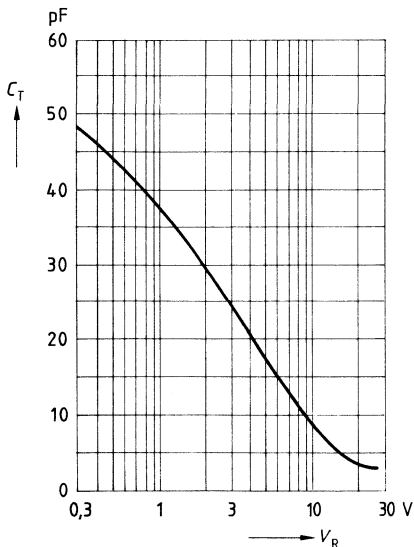

Preliminary data

- For Hyperband TV tuners, Bd I
- Capacitance ratio > 19

DO 35 DHD

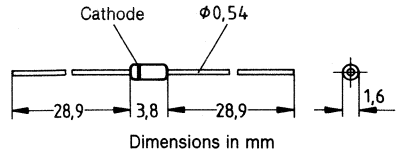

Type	BB 610
Ordering code	Q62702-B400

Maximum ratings

Reverse voltage	V_R	30	V
Forward current	I_F	20	mA
$T_A \leq 60^\circ\text{C}$			
Operating temperature range	T_{op}	-55... + 100	$^\circ\text{C}$
Storage temperature range	T_{stg}	-55... + 150	$^\circ\text{C}$



Characteristics ($T_A = 25\text{ }^\circ\text{C}$)

		min	typ	max	
Reverse current	I_R	—	—	20	nA
$V_R = 30\text{ V}$		—	—	200	nA
$30\text{ V}, T_A = 60\text{ }^\circ\text{C}$					
Diode capacitance, $f = 1\text{ MHz}$	C_T	—	69	—	pF
$V_R = 1\text{ V}$		—	3,35	—	pF
28 V					
Capacitance ratio	$\frac{C_{T1}}{C_{T28}}$	19	—	—	—
$V_R = 1\text{ V}, 28\text{ V}; f = 1\text{ MHz}$					
Capacitance matching	$\frac{\Delta C_T}{C_T}$	—	—	2,5	%
$V_R = 1\text{ V} \dots 28\text{ V}, f = 1\text{ MHz}$					
Series resistance	r_s	—	1,3	—	Ω

Diode capacitance $C_T = f(V_R)$
 $f = 1\text{ MHz}$

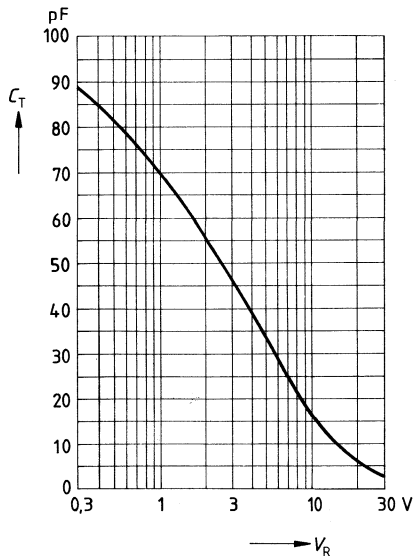

Preliminary data

- For tuning of extended frequency bands in VHF TV tuners
- Miniature plastic package for surface mounting (SMD)

Mini-plast

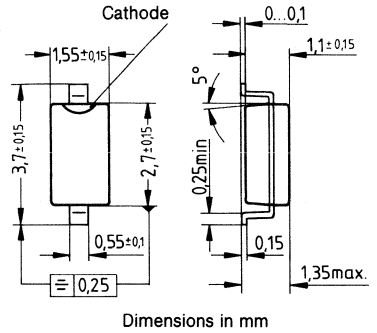

Type	BB 619 A	BB 619 B
Ordering code	Q62702-B401	Q62702-B402

Maximum ratings

Reverse voltage	V_R	30	V
Forward current	I_F	20	mA
$T_A \leq 60^\circ\text{C}$			
Operating temperature range	T_{op}	-55... +100	$^\circ\text{C}$
Storage temperature range	T_{stg}	-55... +100	$^\circ\text{C}$

Characteristics ($T_A = 25\text{ }^\circ\text{C}$)

		min	typ	max	
Reverse current	I_R	—	—	20	nA
$V_R = 30\text{ V}$		—	—	200	nA
$30\text{ V}, T_A = 60\text{ }^\circ\text{C}$					
Diode capacitance, $f = 1\text{ MHz}$	C_T				
BB 619 A: $V_R = 1\text{ V}$		—	37,5	—	pF
28 V		2,5	—	3	pF
BB 619 B: $V_R = 1\text{ V}$		—	39	—	pF
28 V		2,8	—	3,2	pF
Capacitance ratio	$\frac{C_{T1}}{C_{T28}}$	12	—	—	—
$V_R = 1\text{ V}, 28\text{ V}; f = 1\text{ MHz}$					
Capacitance matching	$\frac{\Delta C_T}{C_T}$	—	—	2,5	%
$V_R = 1\text{ V} \dots 28\text{ V}, f = 1\text{ MHz}$					
Series resistance	r_s	—	0,65	—	Ω
Series inductance	L_s	—	2,5	—	nH

Diode capacitance $C_T = f(V_R)$

$f = 1\text{ MHz}$

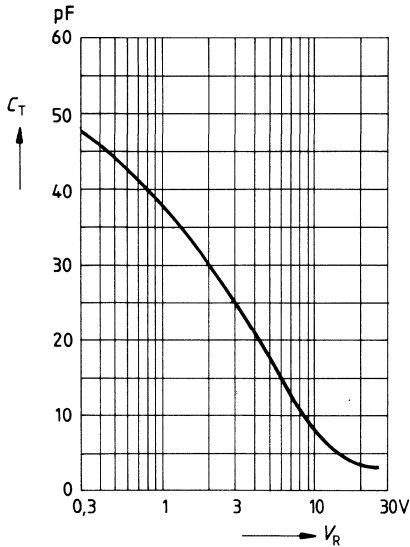

Preliminary data

- For Hyperband TV tuners, Bd I
- Capacitance ratio > 19
- Miniature plastic package for surface mounting (SMD)

Mini-plast

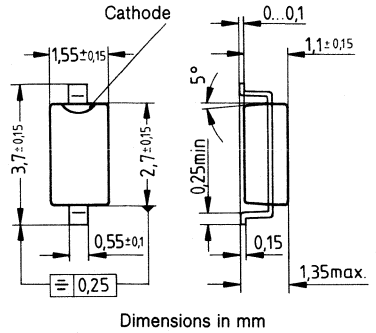

Type	BB 620
Ordering code	Q62702-B403

Maximum ratings

Reverse voltage
 Forward current
 $T_A \leq 60^\circ\text{C}$
 Operating temperature range
 Storage temperature range

V_R	30	V
I_F	20	mA
T_{op}	- 55... + 100	$^\circ\text{C}$
T_{stg}	- 55... + 100	$^\circ\text{C}$

Characteristics ($T_A = 25\text{ }^\circ\text{C}$)

		min	typ	max	
Reverse current	I_R	—	—	20	nA
$V_R = 30\text{ V}$		—	—	200	nA
$30\text{ V}, T_A = 60\text{ }^\circ\text{C}$		—	—	—	—
Diode capacitance, $f = 1\text{ MHz}$	C_T	—	69	—	pF
$V_R = 1\text{ V}$		—	3,35	—	pF
28 V		—	—	—	—
Capacitance ratio	$\frac{C_{T1}}{C_{T28}}$	19	—	—	—
$V_R = 1\text{ V}, 28\text{ V}; f = 1\text{ MHz}$		—	—	—	—
Capacitance matching	$\frac{\Delta C_T}{C_T}$	—	—	2,5	%
$V_R = 1\text{ V} \dots 28\text{ V}, f = 1\text{ MHz}$		—	—	—	—
Series resistance	r_s	—	1,3	—	Ω

Diode capacitance $C_T = f(V_R)$

$f = 1\text{ MHz}$

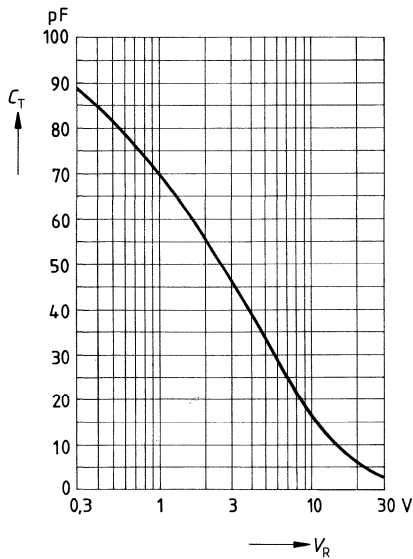

Preliminary data

- Frequency range up to 2 GHz; special design for use in TV-sat indoor units
- High capacitance ratio
- Miniature plastic package for surface mounting (SMD)

SOT 23

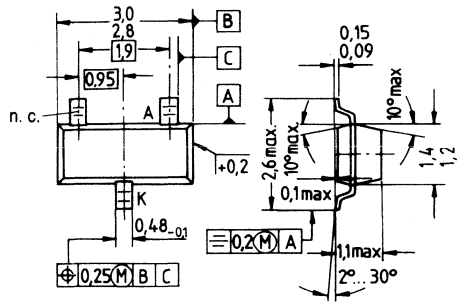

Dimensions in mm

Type	BB 801
Ordering code	bulk: Q62702-B346
Marking	UF

Maximum ratings

- Reverse voltage
- Peak reverse voltage
- Forward current
- $T_A \leq 60^\circ\text{C}$
- Operating temperature
- Storage temperature range

V_R	28	V
V_{RM}	30	V
I_F	20	mA
T_{op}	100	$^\circ\text{C}$
T_{stg}	-65... +150	$^\circ\text{C}$

Characteristics ($T_A = 25\text{ }^\circ\text{C}$)

		min	typ	max	
Reverse current	I_R	—	—	20	nA
$V_R = 28\text{ V}$		—	—	500	nA
$28\text{ V}, T_A = 60\text{ }^\circ\text{C}$					
Diode capacitance, $f = 1\text{ MHz}$	C_T	—	9	—	pF
$V_R = 1\text{ V}$		—	1	—	pF
28 V					
Capacitance ratio	$\frac{C_T1}{C_T28}$	—	9	—	—
$V_R = 1\text{ V}, 28\text{ V}; f = 1\text{ MHz}$					
Series resistance	r_s	—	1	—	Ω
$C_T = 9\text{ pF}, f = 100\text{ MHz}$					
Case capacitance	C_C	—	0,1	—	pF
$f = 1\text{ MHz}$					

Diode capacitance $C_T = f(V_R)$
 $f = 1\text{ MHz}$

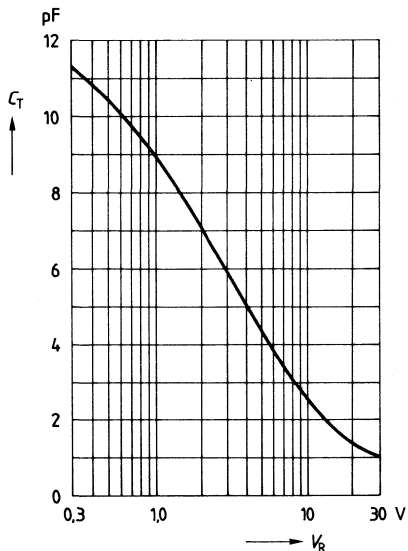

SOT 23

- For FM tuners
- Monolithic chip with common cathode for perfect tracking of both diodes
- Uniform "square law" characteristics
- Ideal Hifi tuning device when used in low-distortion, back-to-back configuration
- Miniature plastic package for surface mounting (SMD)

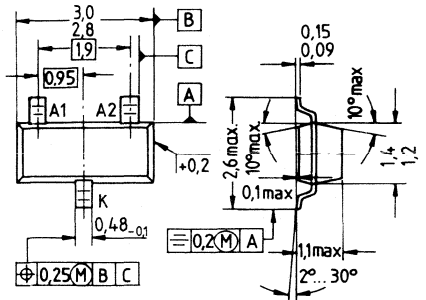

Dimensions in mm

Type	BB 804	
Ordering code	bulk: Q62702-B328	taped: Q62702-B356
Marking	SF (see next page for marking of capacitance subgroups)	

Maximum ratings per diode

Reverse voltage	V_R	18	V
Peak reverse voltage	V_{RM}	20	V
Forward current	I_F	50	mA
$T_A \leq 60^\circ\text{C}$			
Operating temperature	T_{OP}	100	$^\circ\text{C}$
Storage temperature range	T_{STG}	-65... + 150	$^\circ\text{C}$

Characteristics per diode ($T_A = 25\text{ }^\circ\text{C}$)

		min	typ	max	
Reverse current	I_R				
$V_R = 16\text{ V}$		—	—	20	nA
$16\text{ V}, T_A = 60\text{ }^\circ\text{C}$		—	—	200	nA
Diode capacitance	C_T	42	—	47,5	pF
$V_R = 2\text{ V}, f = 1\text{ MHz}$					
Capacitance ratio	$\frac{C_{T2}}{C_{T8}}$	1,65	1,7	—	—
$V_R = 2\text{ V}, 8\text{ V}; f = 1\text{ MHz}$					
Series resistance	r_s	—	0,25	—	Ω
$C_T = 38\text{ pF}, f = 100\text{ MHz}$					
Q factor	Q	—	170	—	—
$C_T = 38\text{ pF}, f = 100\text{ MHz}$					
Temperature coefficient of diode capacitance	TC_C	—	330	—	ppm/K
$V_R = 2\text{ V}, f = 1\text{ MHz}$					
Capacitance subgroups ¹⁾	C_T				
$V_R = 2\text{ V}, f = 1\text{ MHz}$					
Subgroups: 0		42	—	43,5	pF
1		43	—	44,5	pF
2		44	—	45,5	pF
3		45	—	46,5	pF
4		46	—	47,5	pF

¹⁾ The capacitance subgroup is marked by the subgroup number printed on the component and the package label. A packaging unit (e.g. 8-mm tape) contains diodes of one subgroup only. Delivery of discrete capacitance subgroups requires a special agreement.

Diode capacitance $C_T = f(V_R)$
per diode, $f = 1$ MHz

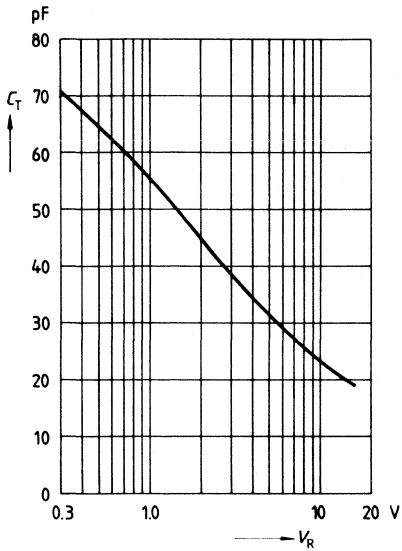

Capacitance ratio $\frac{C_{Tref}}{C_T} = f(V_R)$
per diode; $V_{ref} = 1$ V, 2 V; $f = 1$ MHz

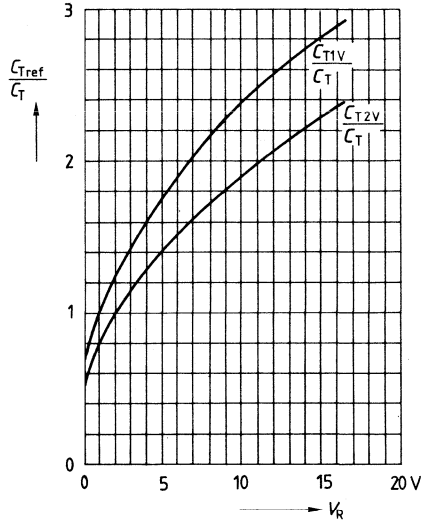

Temperature coefficient $TC_C = f(V_R)$
per diode, $f = 1$ MHz

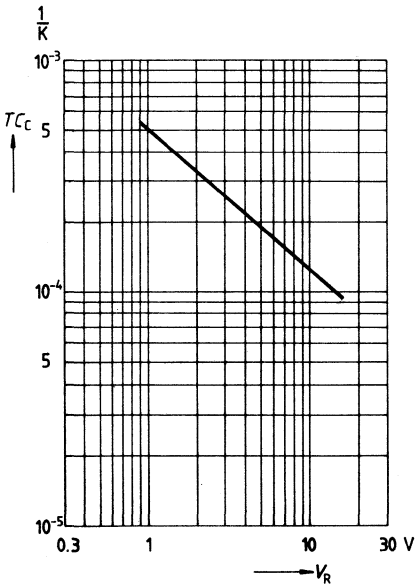

Preliminary data

- High capacitance ratio for FM tuners with extended frequency band
- Monolithic chip (common cathode) for perfect tracking of both diodes
- Capacitance subgroups available upon request
- Miniature plastic package for surface mounting (SMD)

SOT 23

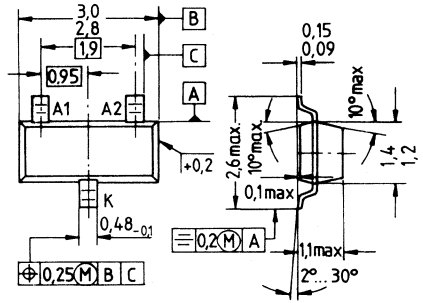

Dimensions in mm

Type	BB 814
Ordering code	Q62702-B404
Marking	SH

Maximum ratings per diode

- Reverse voltage
- Peak reverse voltage
- Forward current
- $T_A \leq 60^\circ\text{C}$
- Storage temperature range

V_R	18	V
V_{RM}	20	V
I_F	50	mA
T_{stg}	- 55... + 100	$^\circ\text{C}$

Characteristics per diode ($T_A = 25\text{ }^\circ\text{C}$)

		min	typ	max	
Reverse current	I_R	—	—	20	nA
$V_R = 16\text{ V}$		—	—	0,2	μA
$16\text{ V}, T_A = 60\text{ }^\circ\text{C}$		—	—	—	—
Diode capacitance, $f = 1\text{ MHz}$	C_T	—	44,75	—	pF
$V_R = 2\text{ V}$		—	20,3	—	pF
8 V		—	—	—	—
Capacitance ratio	$\frac{C_{T2}}{C_{T8}}$	—	2,2	—	—
$V_R = 2\text{ V}, 8\text{ V}; f = 1\text{ MHz}$	$\frac{C_{T8}}{C_{T2}}$	—	—	—	—

Diode capacitance $C_T = f(V_R)$

per diode, $f = 1\text{ MHz}$

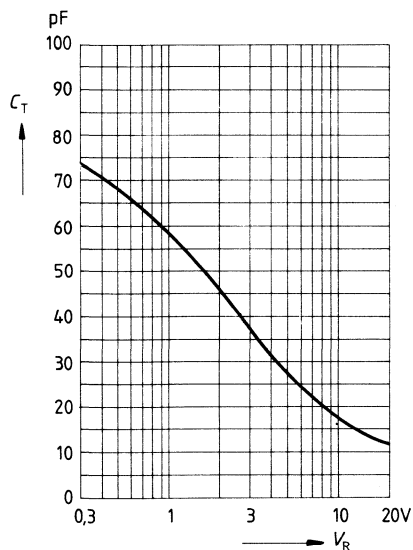

Transistors



- For common emitter IF TV amplifier stages
- Low feedback capacitance due to shield diffusion

TO 92

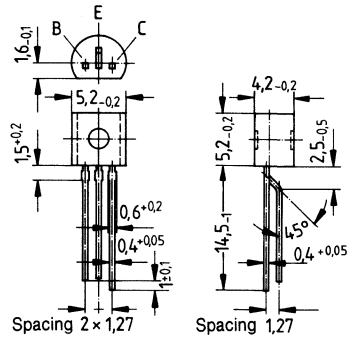

Dimensions in mm

Type	BF 199
Ordering code	Q62702-F355

Maximum ratings

Collector-emitter voltage	V_{CEO}	25	V
Collector-base voltage	V_{CBO}	40	V
Emitter-base voltage	V_{EBO}	4	V
Collector current	I_C	25	mA
Base current	I_B	2	mA
Total power dissipation ($T_A \leq 25^\circ\text{C}$)	P_{tot}	500	mW
Junction temperature	T_j	150	$^\circ\text{C}$
Storage temperature range	T_{stg}	-55... + 150	$^\circ\text{C}$

Thermal resistance

Junction — ambient	R_{thJA}	≤ 250	K/W
--------------------	------------	------------	-----

Characteristics ($T_A = 25^\circ\text{C}$)

DC characteristics		min	typ	max	
Collector cutoff current $V_{CB} = 40\text{ V}$	I_{CBO}	—	—	100	nA
DC current gain $I_C = 7\text{ mA}, V_{CE} = 10\text{ V}$	h_{FE}	38	85	—	—
Base-emitter voltage $I_C = 7\text{ mA}, V_{CE} = 10\text{ V}$	V_{BE}	—	780	—	mV
AC characteristics					
Transition frequency $I_C = 5\text{ mA}, V_{CE} = 10\text{ V}, f = 100\text{ MHz}$	f_T	—	550	—	MHz
Collector-base capacitance $V_{CE} = 10\text{ V}, V_{BE} = 0, f = 1\text{ MHz}$	c_{cb}	—	0,32	—	pF
Optimum power gain $I_C = 7\text{ mA}, V_{CE} = 10\text{ V}, f = 35\text{ MHz}$	$G_{pe\text{ opt}}$	—	43	—	dB
Y parameters, common emitter $I_C = 7\text{ mA}, V_{CE} = 10\text{ V}, f = 35\text{ MHz}$					
	g_{11e}	—	4,8	—	mS
	c_{11e}	—	45	—	pF
	$ y_{12e} $	—	70	—	μS
	φ_{12e}	—	-95	—	deg
	$ y_{21e} $	—	175	—	mS
	φ_{21e}	—	-25	—	deg
	g_{22e}	—	80	—	μS
	c_{22e}	—	1,7	—	pF

Total power dissipation $P_{tot} = f(T_A)$

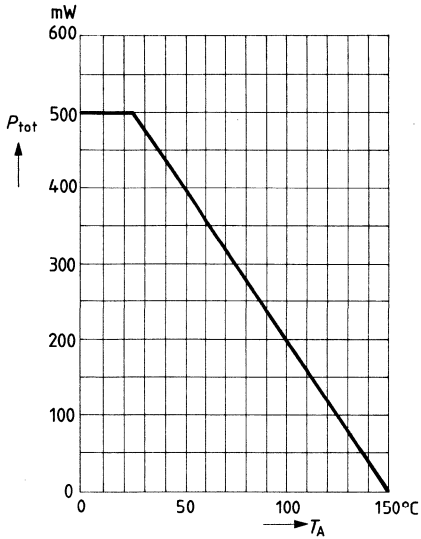

Collector-emitter breakdown voltage $V_{(BR)CER} = f(R_{BE})$

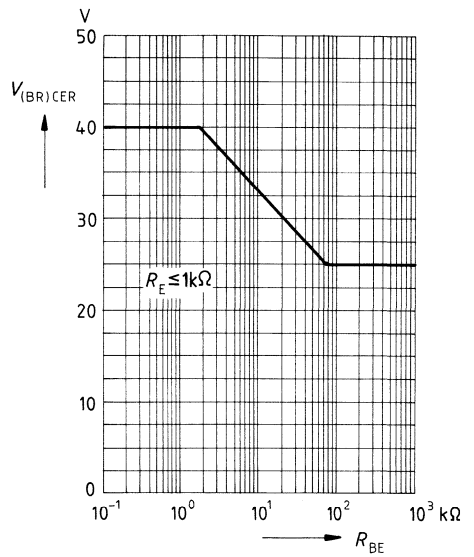

Collector current $I_C = f(V_{BE})$

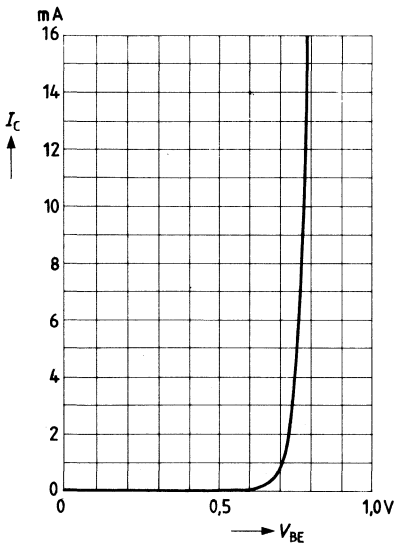

Collector current $I_C = f(I_B)$

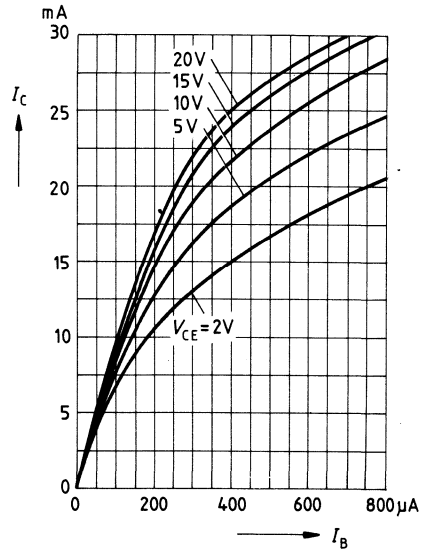

Output characteristics $I_C = f(V_{CE})$

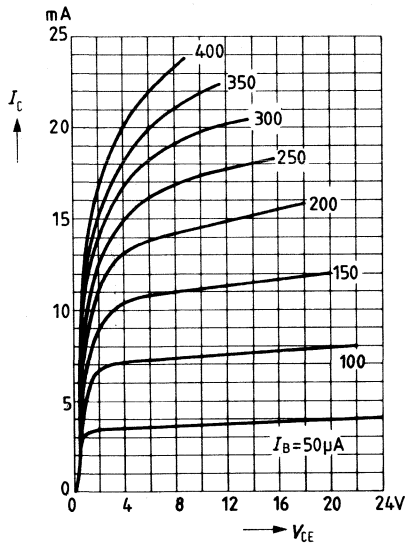

Collector-base capacitance $C_{cb} = f(V_{CB})$
 $f = 1$ MHz

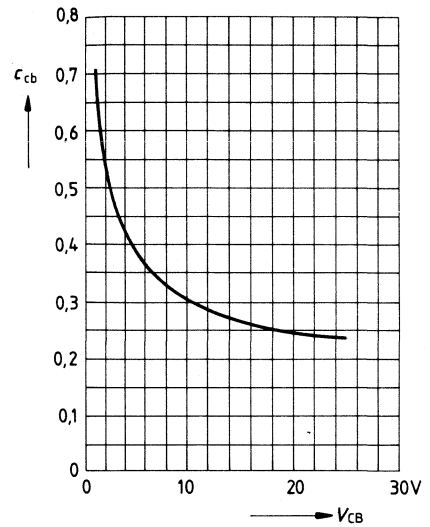

Forward transfer admittance $y_{21e} = f(I_C)$
 $f = 35$ MHz

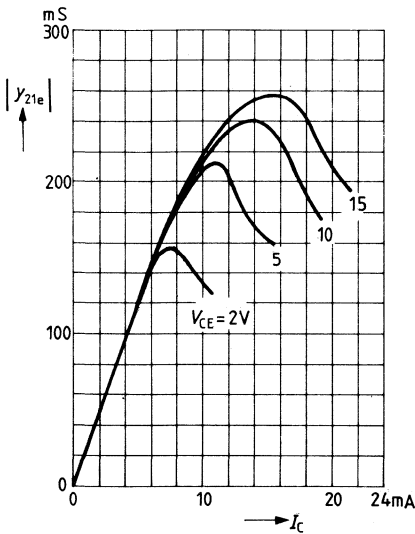

Transition frequency $f_T = f(I_C)$
 $f = 100$ MHz

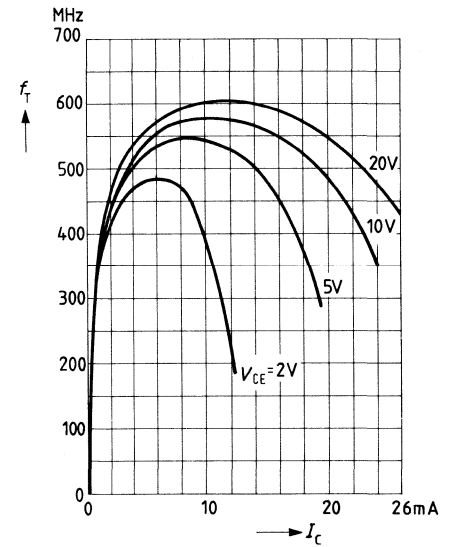

- For AM and FM stages
- Low feedback capacitance due to shield diffusion
- Low output conductance

TO 92

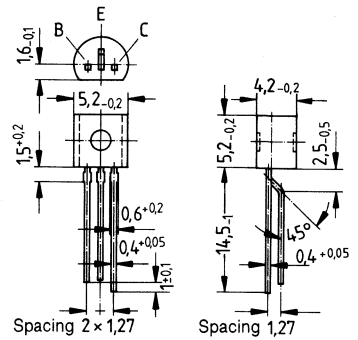

Dimensions in mm

Type	BF 240	BF 241
Ordering code	Q62702-F302	Q62702-F303

Maximum ratings

Collector-emitter voltage	V_{CEO}	40	V
Collector-base voltage	V_{CBO}	40	V
Emitter-base voltage	V_{EBO}	4	V
Collector current	I_C	25	mA
Base current	I_B	2	mA
Total power dissipation ($T_A \leq 45^\circ\text{C}$)	P_{tot}	250	mW
Junction temperature	T_j	150	$^\circ\text{C}$
Storage temperature range	T_{stg}	-55... +150	$^\circ\text{C}$

Thermal resistance

Junction — ambient	R_{thJA}	≤ 420	K/W
--------------------	------------	------------	-----

Characteristics ($T_A = 25^\circ\text{C}$)

DC characteristics

		min	typ	max	
Collector-base breakdown voltage $I_C = 10\ \mu\text{A}$	$V_{(BR)CBO}$	40	—	—	V
Emitter-base breakdown voltage $I_E = 10\ \mu\text{A}$	$V_{(BR)EBO}$	4	—	—	V
Collector cutoff current $V_{CB} = 20\ \text{V}$	I_{CBO}	—	—	100	nA
Base-emitter voltage $I_C = 1\ \text{mA}, V_{CE} = 10\ \text{V}$	V_{BE}	—	700	—	mV
DC current gain $I_C = 1\ \text{mA}, V_{CE} = 10\ \text{V}$	h_{FE}				
BF 240		65	—	220	—
BF 241		35	—	125	—

AC characteristics

Transition frequency $I_C = 1\ \text{mA}, V_{CE} = 10\ \text{V}$	f_T	—	400	—	MHz
Collector-base capacitance $V_{CE} = 10\ \text{V}, V_{BE} = 0\ \text{V}, f = 1\ \text{MHz}$	C_{cb}	—	0,3	—	pF
Noise figure $I_C = 1\ \text{mA}, V_{CE} = 10\ \text{V}, f = 100\ \text{kHz}$ $R_S = 300\ \Omega$	F	—	1,7	—	dB
Output conductance $I_C = 1\ \text{mA}, V_{CE} = 10\ \text{V}, f = 10,7\ \text{MHz}$ $0,5\ \text{MHz}$	g_{22e}	—	—	10,5 8,3	μS μS

Total power dissipation $P_{\text{tot}} = f(T_A)$

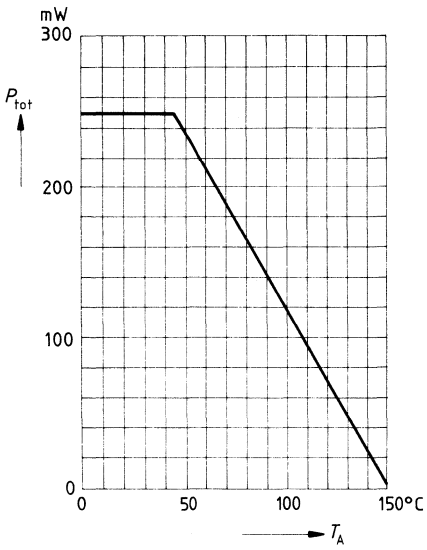

- For AM and FM stages

TO 92

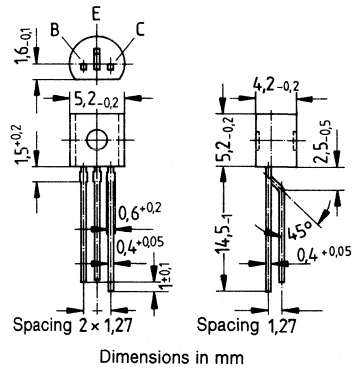

Type	BF 254	BF 255
Ordering code	Q62702-F201	Q62702-F202

Maximum ratings

Collector-emitter voltage	V_{CE0}	20	V
Collector-base voltage	V_{CES}	30	V
Emitter-base voltage	V_{EBO}	5	V
Collector current	I_C	30	mA
Total power dissipation ($T_A \leq 45^\circ\text{C}$)	P_{tot}	250	mW
Junction temperature	T_j	150	$^\circ\text{C}$
Storage temperature range	T_{stg}	-65... +150	$^\circ\text{C}$

Thermal resistance

Junction — ambient	R_{thJA}	≤ 420	K/W
--------------------	------------	------------	-----

Characteristics ($T_A = 25^\circ\text{C}$)

DC characteristics		min	typ	max	
DC current gain $I_C = 1\text{ mA}, V_{CE} = 10\text{ V}$	h_{FE}				
BF 254		65	—	220	—
BF 255		35	—	130	—
Base-emitter voltage $I_C = 1\text{ mA}, V_{CE} = 10\text{ V}$	V_{BE}	—	0,68	—	V

AC characteristics

Transition frequency $I_C = 1\text{ mA}, V_{CE} = 10\text{ V}, f = 100\text{ MHz}$	f_T				
BF 254		—	260	—	MHz
BF 255		—	220	—	MHz
Collector-base capacitance $V_{CB} = 10\text{ V}, V_{BE} = 0\text{ V}, f = 1\text{ MHz}$	C_{cb}	—	0,6	—	pF
Collector-emitter capacitance $V_{CE} = 10\text{ V}, V_{BE} = 0\text{ V}, f = 1\text{ MHz}$	C_{ce}	—	0,6	—	pF
Noise figure $I_C = 1\text{ mA}, V_{CE} = 10\text{ V}$	F				
$f = 1\text{ MHz}, g_s = 1,5\text{ mS}^{1)}$		—	1,2	—	dB
100 MHz, 10 mS ¹⁾		—	3,8	—	dB

¹⁾ g_s = Generator conductance

AC characteristics (continued)

Y parameters, typical values, $I_C = 10\text{ V}$

f MHz		g_{11} mS	b_{11} mS	$ y_{12} $ μS	φ_{12} deg.	$ y_{21} $ mS	φ_{21} deg.	g_{22} μS	b_{22} μS
Common emitter									
0,45	BF 254	0,3	0,06	1,7	-90	38	0	3,2	3,4
	BF 255	0,45	0,08	1,7	-90	38	0	2,7	3,4
10,7	BF 254	0,4	1,5	41	-90	37	-10	4	8,1
	BF 255	0,5	1,75	41	-90	37	-10	3,8	8,1
Common base									
100	BF 255	34	-3,5	250	-85	33	150	18	700

Total power dissipation $P_{\text{tot}} = f(T_A)$

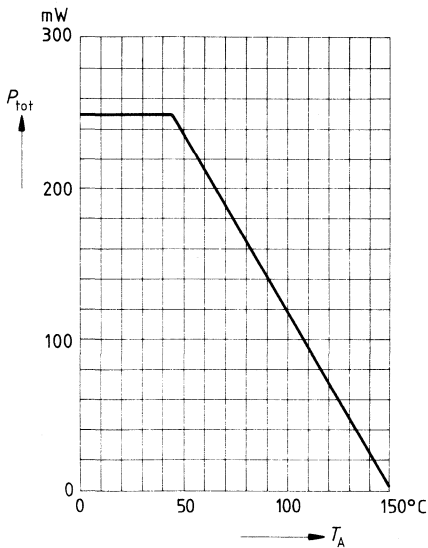

Characteristics ($T_A = 25^\circ\text{C}$)**DC characteristics**

		min	typ	max	
Collector-emitter breakdown voltage $I_C = 2\text{ mA}$, $I_B = 0$	$V_{(BR)CEO}$	30	—	—	V
Collector-base breakdown voltage $I_C = 10\text{ }\mu\text{A}$, $I_E = 0$	$V_{(BR)CBO}$	40	—	—	V
Emitter-base breakdown voltage $I_E = 10\text{ }\mu\text{A}$	$V_{(BR)EBO}$	4	—	—	V
Collector cutoff current $V_{CB} = 20\text{ V}$	I_{CBO}	—	—	60	nA
DC current gain $I_C = 4\text{ mA}$, $V_{CE} = 10\text{ V}$	h_{FE}	30	80	—	—

AC characteristics

Transition frequency $I_C = 1\text{ mA}$, $V_{CE} = 10\text{ V}$, $f = 100\text{ MHz}$ 5 mA , 10 V , 100 MHz	f_T	—	400 560	—	MHz MHz
Collector-emitter capacitance $V_{CE} = 10\text{ V}$, $V_{BE} = 0\text{ V}$, $f = 1\text{ MHz}$	C_{ce}	—	0,1	—	pF
Noise figure $I_C = 5\text{ mA}$, $V_{CE} = 10\text{ V}$, $f = 100\text{ MHz}$ $R_S = 60\text{ }\Omega$	F	—	3	—	dB

Characteristics ($T_A = 25^\circ\text{C}$)

DC characteristics

		min	typ	max	
Collector-emitter breakdown voltage $I_C = 2\text{mA}$	$V_{(BR)CEO}$	40	—	—	V
Collector-base breakdown voltage $I_C = 10\ \mu\text{A}$	$V_{(BR)CBO}$	40	—	—	V
Emitter-base breakdown voltage $I_E = 10\ \mu\text{A}$	$V_{(BR)EBO}$	4	—	—	V
Collector cutoff current $V_{CB} = 30\text{V}$	I_{CBO}	—	—	50	nA
DC current gain $I_C = 1\text{mA}$, $V_{CE} = 10\text{V}$	h_{FE}				
BF 450		65	—	220	—
BF 451		35	—	125	—
Base-emitter voltage $I_C = 1\text{mA}$, $V_{CE} = 10\text{V}$	V_{BE}	—	0,72	—	V

AC characteristics

Transition frequency $I_C = 1\text{mA}$, $V_{CE} = 10\text{V}$, $f = 100\text{MHz}$	f_t				
BF 450		—	375	—	MHz
BF 451		—	325	—	MHz
Collector-base capacitance $V_{CE} = 10\text{V}$, $V_{BE} = 0\text{V}$, $f = 1\text{MHz}$	C_{cb}	—	0,32	—	pF
Noise figure, $V_{CE} = 10\text{V}$	F				
$I_C = 1\text{mA}$, $f = 100\text{kHz}$, $R_S = 300\ \Omega$		—	2	—	dB
2 mA, 100 MHz, 60 Ω		—	3	—	dB
Y parameters , common emitter $I_C = 1\text{mA}$, $V_{CE} = 10\text{V}$ $f = 0,45 \dots 10\text{MHz}$					
BF 450	g_{11e}	—	0,5	—	mS
BF 451		—	0,8	—	mS
BF 450	C_{11e}	—	17	—	pF
BF 451		—	19	—	pF
	$ y_{21e} $	—	35	—	mS
	C_{22e}	—	1,4	—	pF
$f = 500\text{kHz}$	g_{22e}	—	—	8	μS
10 MHz	g_{22e}	—	—	10	μS

Total power dissipation $P_{tot} = f(T_A)$

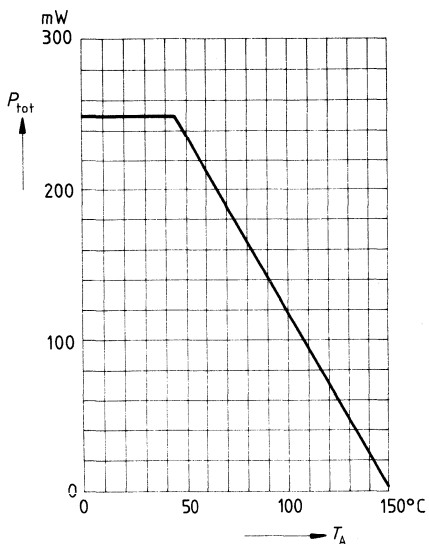

Input characteristics $I_C = f(V_{BE})$
 $V_{CE} = 10 \text{ V}$

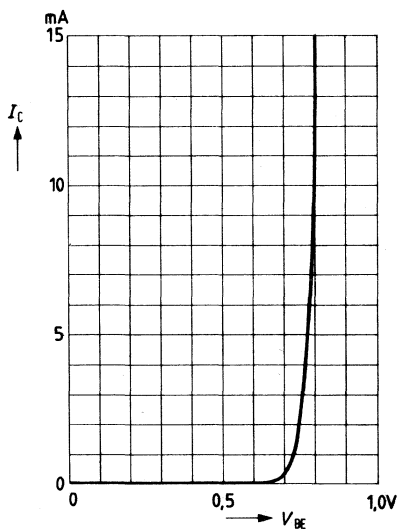

Output characteristics $I_C = f(V_{CE})$

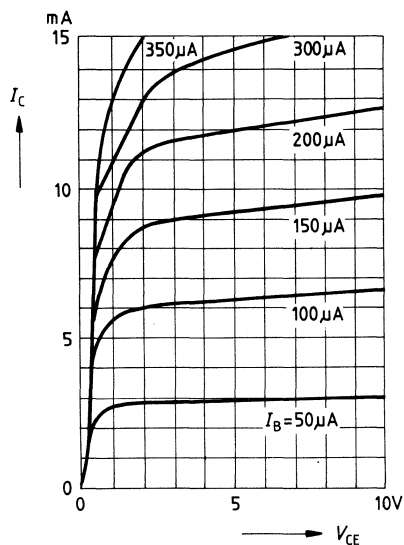

Collector current $I_C = f(I_B)$

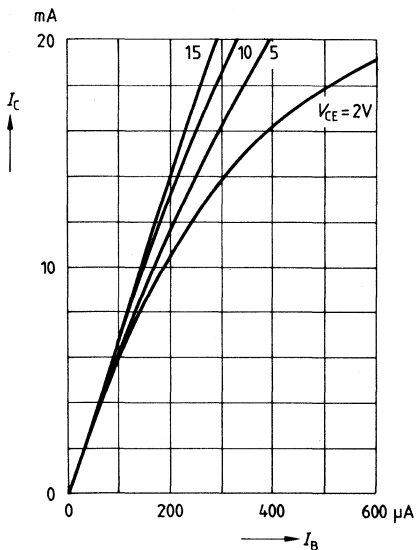

Transition frequency $f_T = f(I_C)$
 $f = 100 \text{ MHz}$

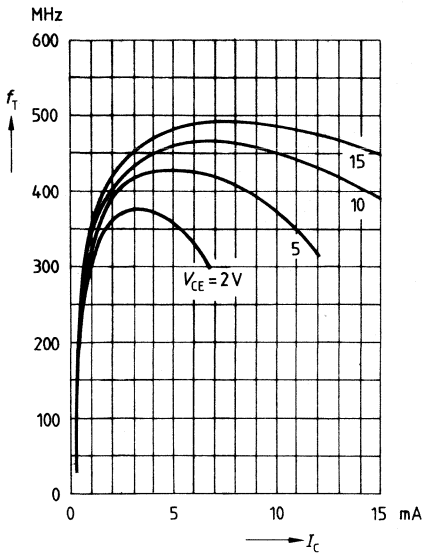

Output conductance $g_{22e} = f(I_C)$
 $V_{CE} = 10 \text{ V}, f = 500 \text{ kHz}$

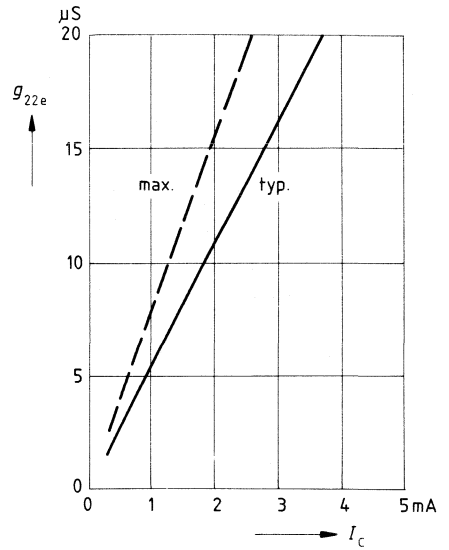

Collector-base capacitance $c_{cb} = f(V_{CB})$
 $f = 1 \text{ MHz}$

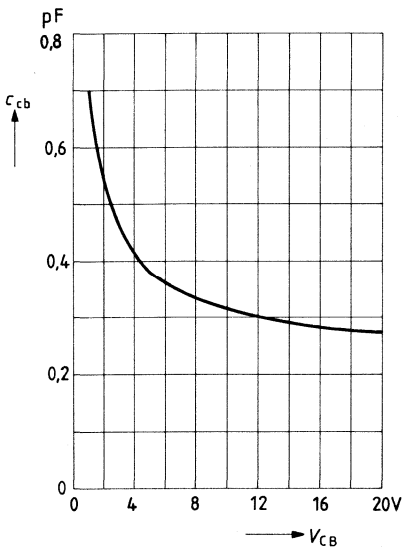

Forward transfer admittance $|y_{21e}| = f(I_C)$
 $f = 10,7 \text{ MHz}$

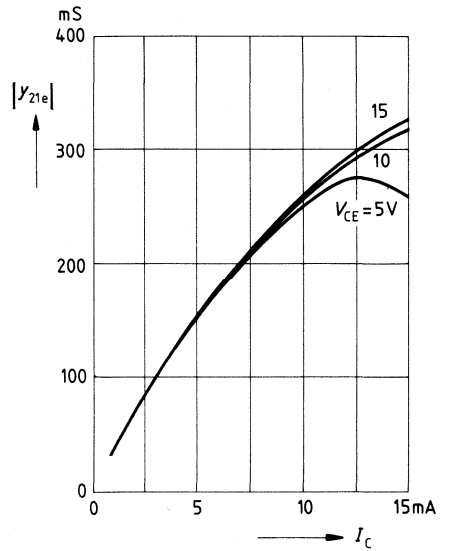

Input admittance y_{11e}

$V_{CE} = 10\text{ V}$

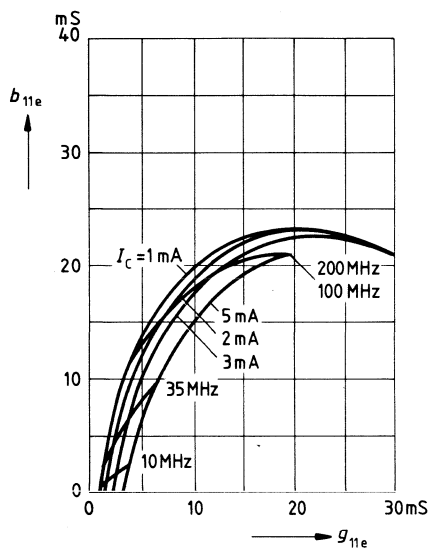

Output admittance y_{22e}

$V_{CE} = 10\text{ V}$

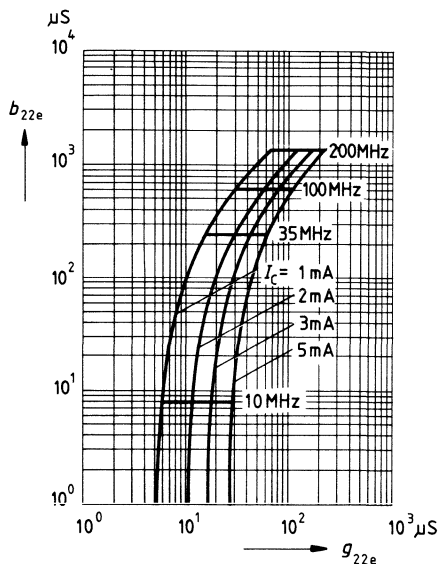

Forward transfer admittance y_{21e}

$V_{CE} = 10\text{ V}$

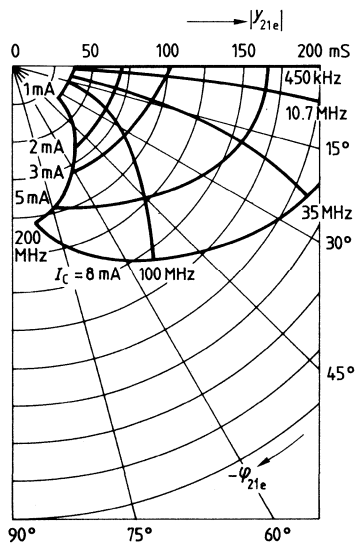

- For VHF mixer and oscillator stages

TO 92

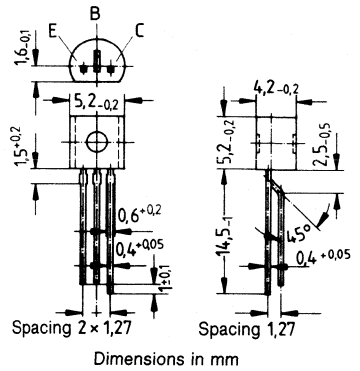

Type	BF 506
Ordering code	Q62702-F534

Maximum ratings

- Collector-emitter voltage
- Collector-base voltage
- Emitter-base voltage
- Collector current
- Base current
- Total power dissipation
($T_A \leq 45^\circ\text{C}$)
- Junction temperature
- Storage temperature range

V_{CEO}	35	V
V_{CBO}	40	V
V_{EBO}	4	V
I_C	30	mA
I_B	5	mA
P_{tot}	300	mW
T_j	150	$^\circ\text{C}$
T_{stg}	-55... + 150	$^\circ\text{C}$

Thermal resistance

- Junction — ambient

R_{thJA}	≤ 350	K/W
------------	------------	-----

Characteristics ($T_A = 25^\circ\text{C}$)

DC characteristics		min	typ	max	
Collector-emitter breakdown voltage $I_C = 2\text{ mA}$	$V_{(BR)CEO}$	35	—	—	V
Collector-base breakdown voltage $I_C = 10\ \mu\text{A}$	$V_{(BR)CBO}$	40	—	—	V
Emitter-base breakdown voltage $I_E = 10\ \mu\text{A}$	$V_{(BR)EBO}$	4	—	—	V
Collector cutoff current $V_{CB} = 20\text{ V}$	I_{CBO}	—	—	100	nA
DC current gain $I_C = 3\text{ mA}, V_{CE} = 10\text{ V}$	h_{FE}	25	—	—	—

AC characteristics					
Transition frequency $I_C = 2\text{ mA}, V_{CE} = 10\text{ V}, f = 100\text{ MHz}$	f_T	—	550	—	MHz
Collector-emitter capacitance $V_{CB} = 10\text{ V}, V_{BE} = 0\text{ V}, f = 1\text{ MHz}$	C_{ce}	—	0,12	—	pF
Noise figure $I_C = 2\text{ mA}, V_{CB} = 10\text{ V}, f = 200\text{ MHz}$ $R_S = 60\ \Omega$	F	—	3	—	dB

- For broadband amplifier and oscillator applications up to 1 GHz
- Miniature plastic package for surface mounting (SMD)

SOT 23

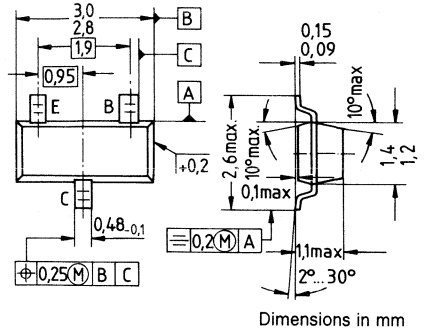

Type	BF 517	
Ordering code	bulk: Q62702-F988	taped: Q62702-F78
Marking	LR	

Maximum ratings

Collector-emitter voltage	V_{CEO}	15	V
Collector-base voltage	V_{CBO}	20	V
Emitter-base voltage	V_{EBO}	3	V
Collector current	I_C	25	mA
Base current	I_B	5	mA
Total power dissipation ($T_A \leq 25^\circ\text{C}$)	P_{tot}	280	mW
Junction temperature	T_j	150	$^\circ\text{C}$
Storage temperature range	T_{stg}	-65... +150	$^\circ\text{C}$

Thermal resistance

Junction — ambient	R_{thJA}	≤ 450	K/W ¹⁾
--------------------	------------	------------	-------------------

¹⁾ Package mounted on alumina 16.7 mm × 15 mm × 0.7 mm

Characteristics ($T_A = 25^\circ\text{C}$)

DC characteristics		min	typ	max	
Collector-emitter breakdown voltage $I_C = 1\text{ mA}, I_B = 0$	$V_{(BR)CEO}$	15	—	—	V
Collector cutoff current $V_{CB} = 15\text{ V}, I_E = 0$	I_{CBO}	—	—	50	nA
DC current gain $I_C = 5\text{ mA}, V_{CE} = 10\text{ V}$	h_{FE}	25	—	250	—
Collector-emitter saturation voltage $I_C = 10\text{ mA}, I_B = 1\text{ mA}$	V_{CEsat}	—	0,1	0,5	V
Base-emitter saturation voltage $I_C = 10\text{ mA}, I_B = 1\text{ mA}$	V_{BEsat}	—	—	0,95	V

AC characteristics

Transition frequency $I_C = 5\text{ mA}, V_{CE} = 10\text{ V}, f = 200\text{ MHz}$	f_T	1	2	—	GHz
Collector-base capacitance $V_{CB} = 10\text{ V}, V_{BE} = 0\text{ V}, f = 1\text{ MHz}$	c_{cb}	0,3	0,5	0,75	pF
Collector-emitter capacitance $V_{CE} = 10\text{ V}, V_{BE} = 0\text{ V}, f = 1\text{ MHz}$	c_{ce}	—	0,26	0,4	pF
Noise figure $I_C = 5\text{ mA}, V_{CE} = 10\text{ V}, f = 100\text{ MHz}$ 800 MHz	F	—	2,5	—	dB
		—	5	—	dB

Total power dissipation $P_{\text{tot}} = f(T_A)$

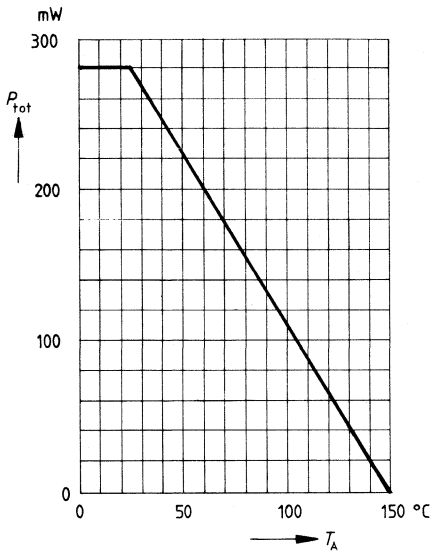

Transition frequency $f_T = f(I_C)$

$V_{\text{CE}} = 10 \text{ V}, f = 200 \text{ MHz}$

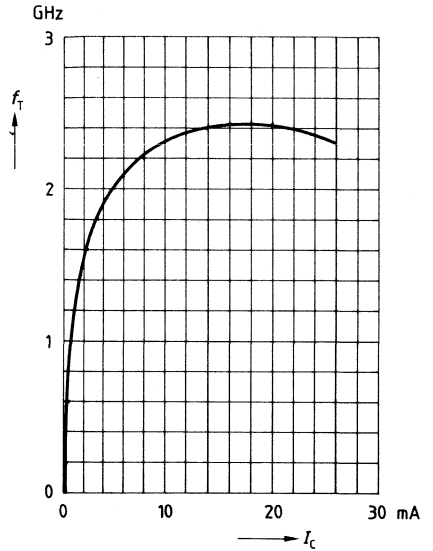

Collector-base capacitance $c_{\text{cb}} = f(V_{\text{CB}})$

$f = 1 \text{ MHz}$

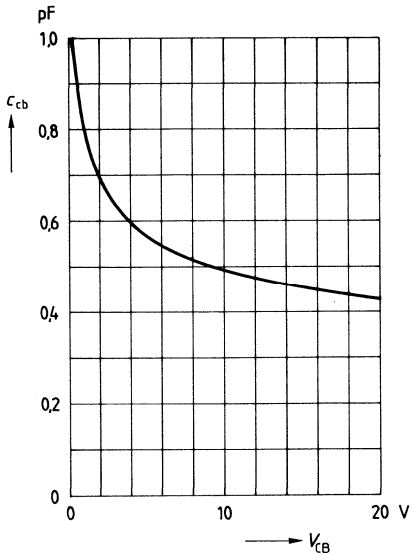

- For common emitter amplifier stages up to 300 MHz
- For mixer applications in AM/FM radios and VHF TV tuners
- Low feedback capacitance due to shield diffusion
- Controlled low output conductance
- Miniature plastic package for surface mounting (SMD)

SOT 23

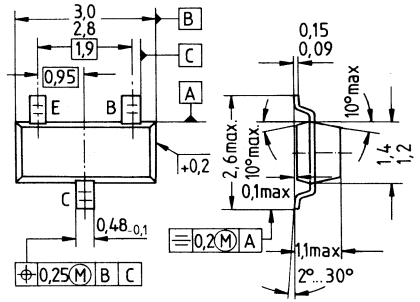

Dimensions in mm

Type	BF 550	
Ordering code	bulk: Q62702-F547	taped: Q62702-F944
Marking	LA	

Maximum ratings

Collector-emitter voltage	V_{CEO}	40	V
Collector-base voltage	V_{CBO}	40	V
Emitter-base voltage	V_{EBO}	4	V
Collector current	I_C	25	mA
Base current	I_B	5	mA
Total power dissipation ($T_A \leq 25^\circ\text{C}$)	P_{tot}	280	mW
Junction temperature	T_j	150	$^\circ\text{C}$
Storage temperature range	T_{stg}	-65... +150	$^\circ\text{C}$

Thermal resistance

Junction — ambient	R_{thJA}	≤ 450	$\text{K/W}^{(1)}$
--------------------	------------	------------	--------------------

¹⁾ Package mounted on alumina 16.7 mm × 15 mm × 0.7 mm

Characteristics ($T_A = 25^\circ\text{C}$)

DC characteristics		min	typ	max	
Collector-emitter breakdown voltage $I_C = 1\text{ mA}, I_B = 0$	$V_{(BR)CEO}$	40	—	—	V
Collector-base breakdown voltage $I_C = 10\text{ }\mu\text{A}, I_E = 0$	$V_{(BR)CBO}$	40	—	—	V
Emitter-base breakdown voltage $I_E = 10\text{ }\mu\text{A}, I_C = 0$	$V_{(BR)EBO}$	4	—	—	V
Collector cutoff current $V_{CB} = 30\text{ V}, I_E = 0$	I_{CBO}	—	—	100	nA
DC current gain $I_C = 1\text{ mA}, V_{CE} = 10\text{ V}$	h_{FE}	50	—	250	—
Base-emitter voltage $I_C = 1\text{ mA}, V_{CE} = 10\text{ V}$	V_{BE}	—	0,72	—	V

AC characteristics

Transition frequency $I_C = 1\text{ mA}, V_{CE} = 10\text{ V}, f = 100\text{ MHz}$	f_T	—	350	—	MHz
Collector-base capacitance $V_{CB} = 10\text{ V}, V_{BE} = 0\text{ V}, f = 1\text{ MHz}$	C_{cb}	—	0,33	—	pF
Collector-emitter capacitance $V_{CE} = 10\text{ V}, V_{BE} = 0\text{ V}, f = 1\text{ MHz}$	C_{ce}	—	0,67	—	pF
Noise figure $V_{CE} = 10\text{ V}$ $I_C = 1\text{ mA}, f = 100\text{ kHz}, R_S = 300\text{ }\Omega$ 2 mA, 100 MHz, 60 Ω	F	—	2	—	dB
		—	3,4	—	dB

Y parameters, common emitter

$I_C = 1\text{ mA}, V_{CE} = 10\text{ V}$					
$f = 0,45 \dots 10\text{ MHz}$	g_{11e}	—	550	—	μS
	C_{11e}	—	17	—	pF
	$ y_{21e} $	—	35	—	mS
	C_{22e}	—	1,3	—	pF
$f = 500\text{ kHz}$	g_{22e}	—	5	8	μS
10 MHz	g_{22e}	—	5	10	μS

Total power dissipation $P_{tot} = f(T_A)$

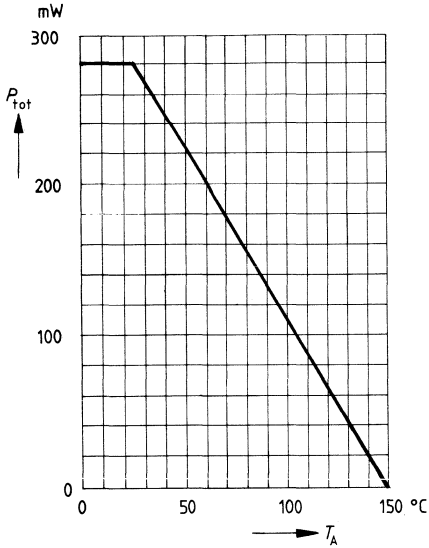

DC current gain $h_{FE} = f(I_C)$

$V_{CE} = 10\text{ V}$

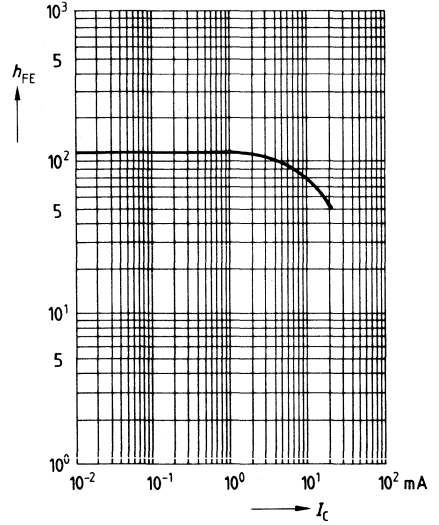

Collector current $I_C = f(V_{BE})$

$V_{CE} = 10\text{ V}$

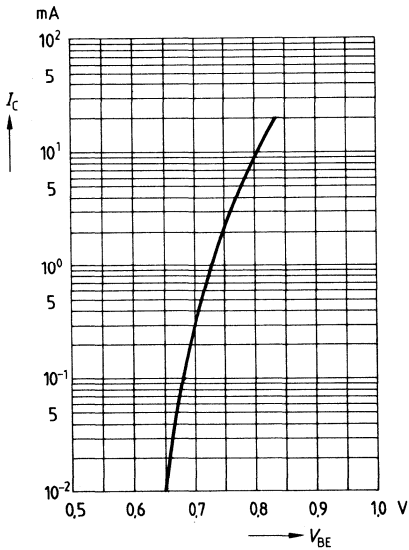

Collector-emitter saturation voltage

$V_{CEsat} = f(I_C)$

$h_{FE} = 10$

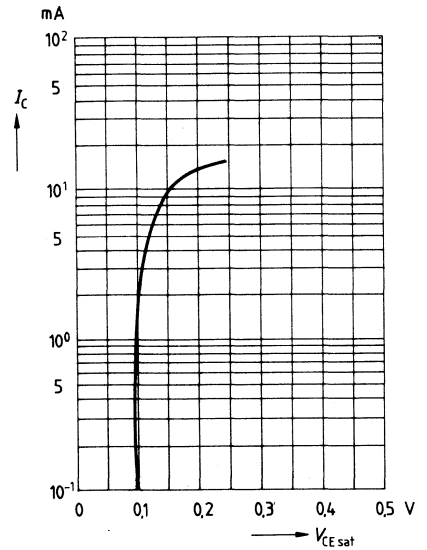

Collector cutoff current $I_{CBO} = f(T_A)$

$V_{CB} = 30 \text{ V}$

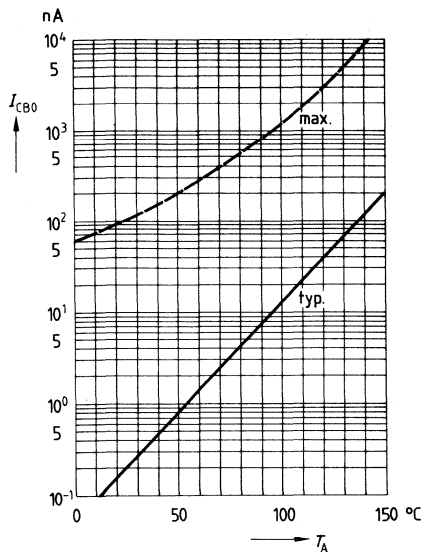

Transition frequency $f_T = f(I_C)$

$f = 100 \text{ MHz}$

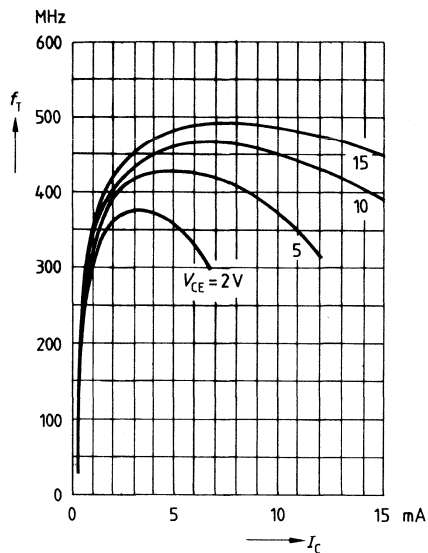

Collector-base capacitance $c_{cb} = f(V_{CB})$

$f = 1 \text{ MHz}$

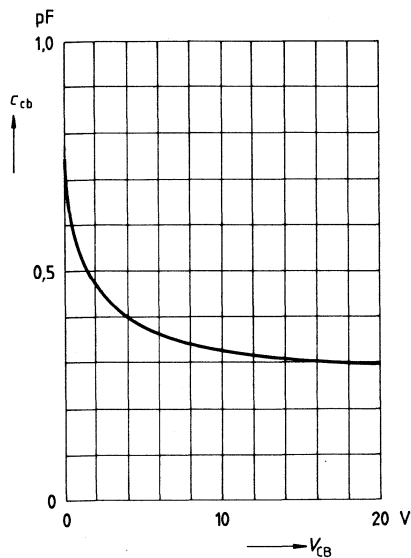

Output conductance $g_{22e} = f(I_C)$

$V_{CE} = 10 \text{ V}, f = 500 \text{ kHz}$

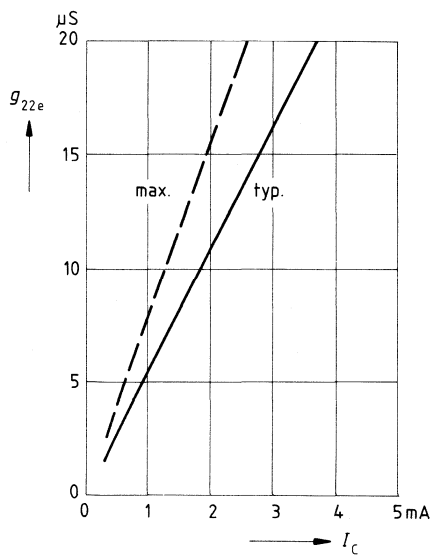

Forward transfer admittance $|y_{21e}| = f(I_C)$
 $f = 10,7 \text{ MHz}$

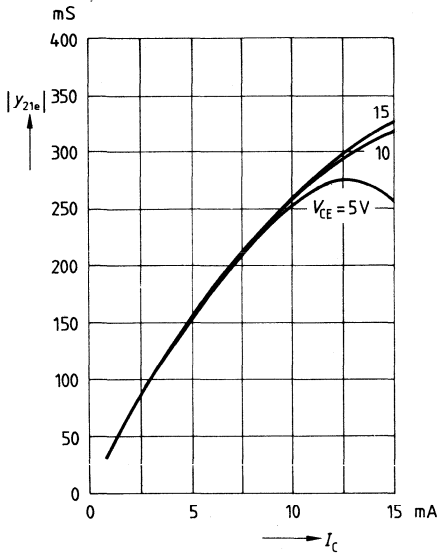

Forward transfer admittance y_{21e}
 $V_{CE} = 10 \text{ V}$

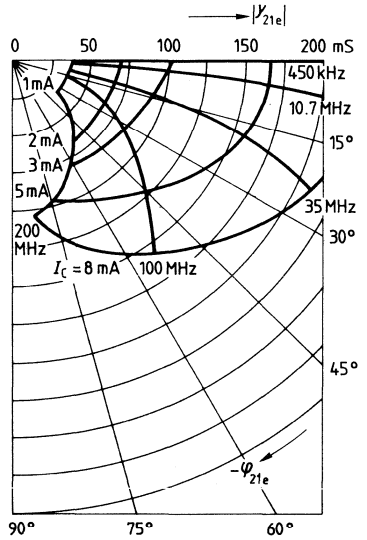

- For general small-signal RF applications up to 300 MHz in amplifier, mixer and oscillator circuits
- Miniature plastic package for surface mounting (SMD)

SOT 23

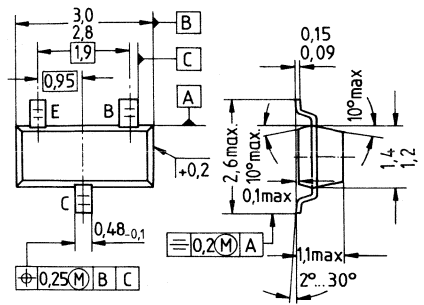

Dimensions in mm

Type	BF 554	
Ordering code	bulk: Q62702-F551	taped: Q62702-F1042
Marking	CC	

Maximum ratings

Collector-emitter voltage	V_{CEO}	20	V
Collector-base voltage	V_{CBO}	30	V
Emitter-base voltage	V_{EBO}	5	V
Collector current	I_C	30	mA
Total power dissipation ($T_A \leq 25^\circ\text{C}$)	P_{tot}	280	mW
Junction temperature	T_j	150	$^\circ\text{C}$
Storage temperature range	T_{stg}	-65... +150	$^\circ\text{C}$

Thermal resistance

Junction — ambient	R_{thJA}	≤ 450	$ \text{K/W}^{1)}$
--------------------	------------	------------	---------------------

¹⁾ Package mounted on alumina 16.7 mm x 15 mm x 0.7 mm

Characteristics ($T_A = 25^\circ\text{C}$)

DC characteristics		min	typ	max	
Collector-emitter breakdown voltage $I_C = 1\text{ mA}, I_B = 0$	$V_{(BR)_{CEO}}$	20	—	—	V
Collector cutoff current $V_{CB} = 20\text{ V}, I_E = 0$	I_{CBO}	—	—	100	nA
DC current gain $I_C = 1\text{ mA}, V_{CE} = 10\text{ V}$	h_{FE}	60	—	250	—
Base-emitter voltage $I_C = 1\text{ mA}, V_{CE} = 10\text{ V}$	V_{BE}	—	0,7	—	V

AC characteristics					
Transition frequency $I_C = 1\text{ mA}, V_{CE} = 10\text{ V}, f = 100\text{ MHz}$	f_T	—	250	—	MHz
Collector-base capacitance $V_{CE} = 10\text{ V}, V_{BE} = 0\text{ V}, f = 1\text{ MHz}$	C_{cb}	—	0,6	—	pF
Noise figure $I_C = 1\text{ mA}, V_{CE} = 10\text{ V}$ $f = 200\text{ kHz}, g_s = 2\text{ mS}$ 1 MHz, 1,5 mS 100 MHz, 10 mS	F	—	1,5	—	dB
		—	1,2	—	dB
		—	3	—	dB
Output conductance $I_C = 1\text{ mA}, V_{CE} = 10\text{ V}, f = 0,5 \dots 10\text{ MHz}$	g_{22e}	—	4	—	μS

Total power dissipation $P_{tot} = f(T_A)$

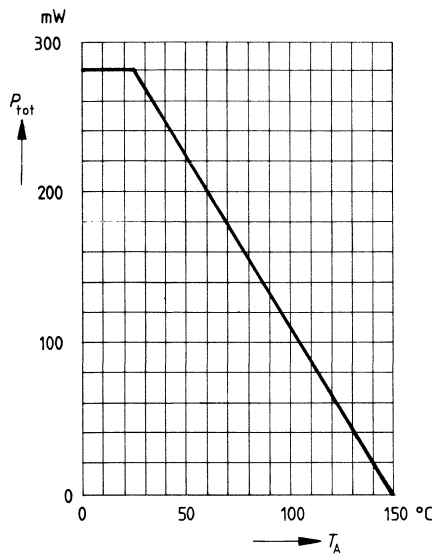

DC current gain $h_{FE} = f(I_C)$

$V_{CE} = 10\text{ V}$

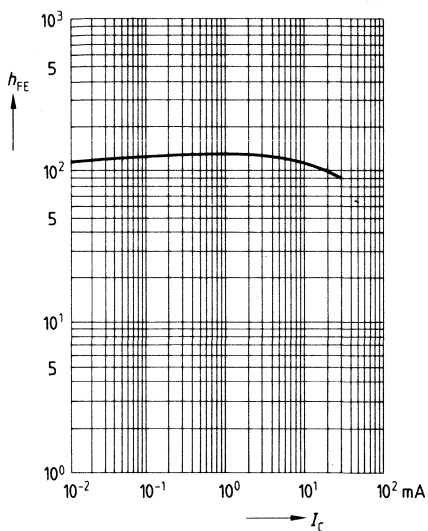

Collector current $I_C = f(V_{BE})$

$V_{CE} = 10\text{ V}$

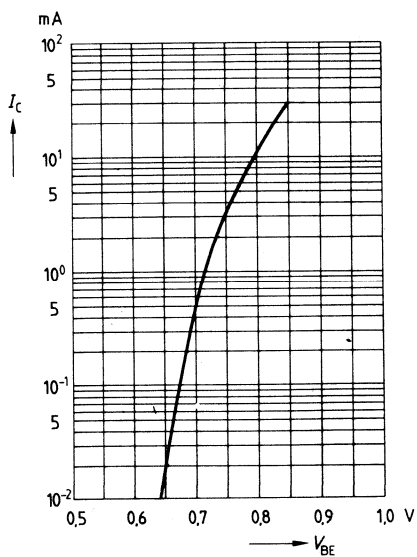

Collector-emitter saturation voltage

$V_{CEsat} = f(I_C)$

$h_{FE} = 10$

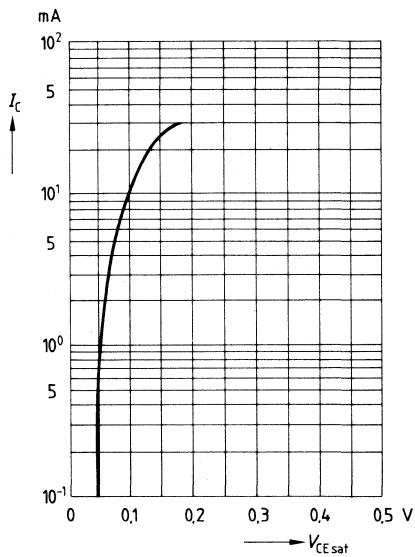

Collector cutoff current $I_{CBO} = f(T_A)$

$V_{CB} = 20\text{ V}$

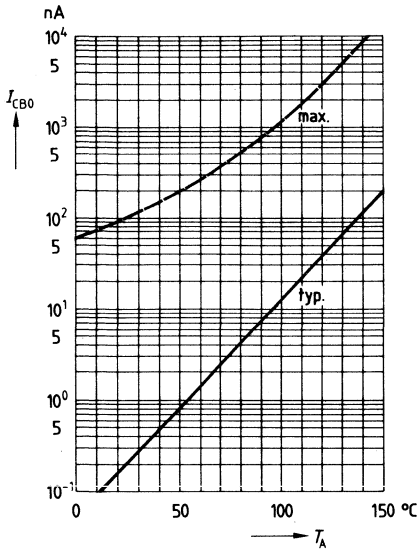

Transition frequency $f_T = f(I_C)$

$V_{CE} = 10\text{ V}, f = 100\text{ MHz}$

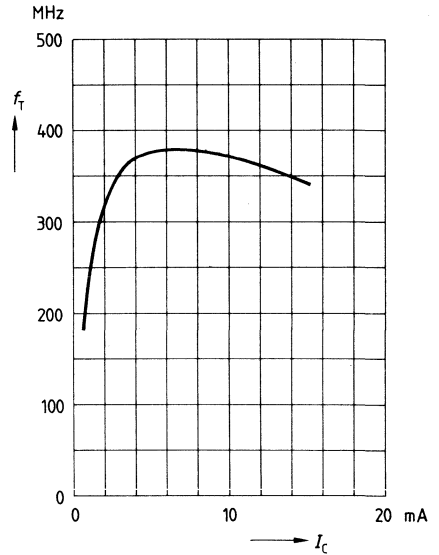

Collector-base capacitance $c_{cb} = f(V_{CB})$

$f = 1\text{ MHz}$

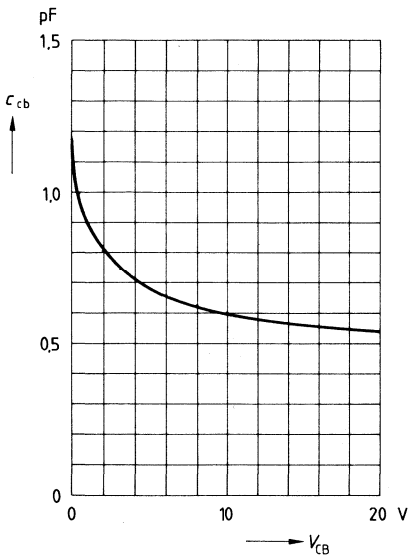

Noise figure $F = f(f)$

$I_C = 1\text{ mA}, V_{CE} = 10\text{ V}, R_S = 60\ \Omega$

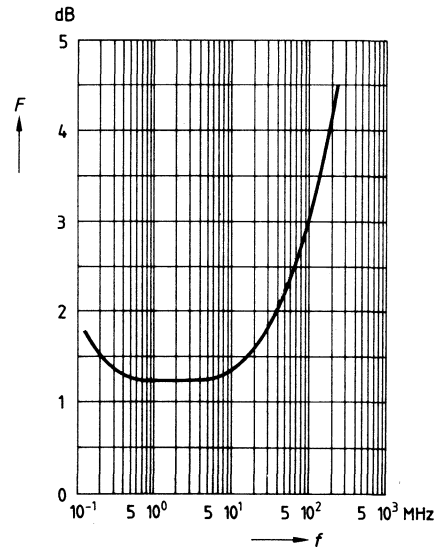

- For oscillators, mixers and self-oscillating mixer stages in UHF TV tuners
- Miniature plastic package for surface mounting (SMD)

SOT 23

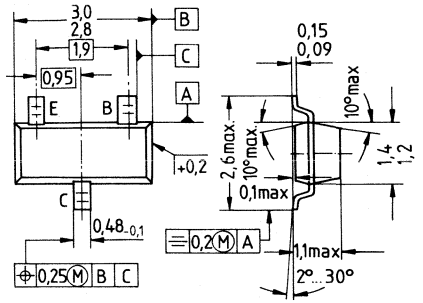

Dimensions in mm

Type	BF 569	
Ordering code	bulk: Q62702-F548	taped: Q62702-F869
Marking	LH	

Maximum ratings

Collector-emitter voltage	V_{CEO}	35	V
Collector-base voltage	V_{CBO}	40	V
Emitter-base voltage	V_{EBO}	3	V
Collector current	I_C	30	mA
Base current	I_B	5	mA
Total power dissipation ($T_A \leq 25^\circ\text{C}$)	P_{tot}	280	mW
Junction temperature	T_j	150	$^\circ\text{C}$
Storage temperature range	T_{stg}	-55... + 150	$^\circ\text{C}$

Thermal resistance

Junction — ambient	R_{thJA}	≤ 450	$\text{K/W}^{(1)}$
--------------------	------------	------------	--------------------

¹⁾ Package mounted on alumina 16.7 mm × 15 mm × 0.7 mm

Characteristics ($T_A = 25^\circ\text{C}$)

DC characteristics		min	typ	max	
Collector-emitter breakdown voltage $I_C = 1\text{ mA}, I_B = 0$	$V_{(BR)CEO}$	35	—	—	V
Collector cutoff current $V_{CB} = 20\text{ V}, I_E = 0$	I_{CBO}	—	—	100	nA
DC current gain $I_C = 3\text{ mA}, V_{CE} = 10\text{ V}$	h_{FE}	20	50	—	—

AC characteristics

Transition frequency $I_C = 3\text{ mA}, V_{CE} = 10\text{ V}, f = 100\text{ MHz}$	f_T	—	950	—	MHz
Collector-base capacitance $V_{CB} = 10\text{ V}, V_{BE} = 0\text{ V}, f = 1\text{ MHz}$	c_{cb}	—	0,32	—	pF
Collector-emitter capacitance $V_{CE} = 10\text{ V}, V_{BE} = 0\text{ V}, f = 1\text{ MHz}$	c_{ce}	—	0,15	—	pF
Noise figure $I_C = 3\text{ mA}, V_{CB} = 10\text{ V}, f = 800\text{ MHz}$ $R_S = 60\ \Omega$	F	—	4,5	—	dB
Common base power gain $I_C = 3\text{ mA}, V_{CB} = 10\text{ V}, f = 800\text{ MHz}$ $R_L = 500\ \Omega$	G_P	—	14,8	—	dB

Total power dissipation $P_{tot} = f(T_A)$

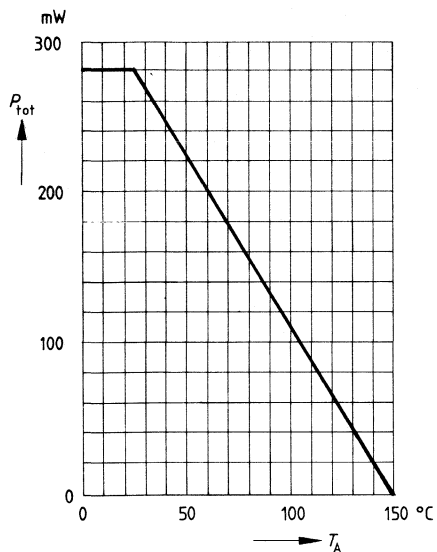

Transition frequency $f_T = f(I_C)$

$V_{CE} = 10\text{ V}, f = 100\text{ MHz}$

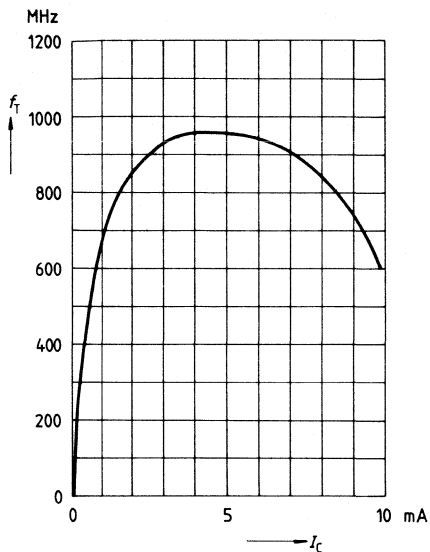

Collector-base capacitance $c_{cb} = f(V_{CB})$

$f = 1\text{ MHz}$

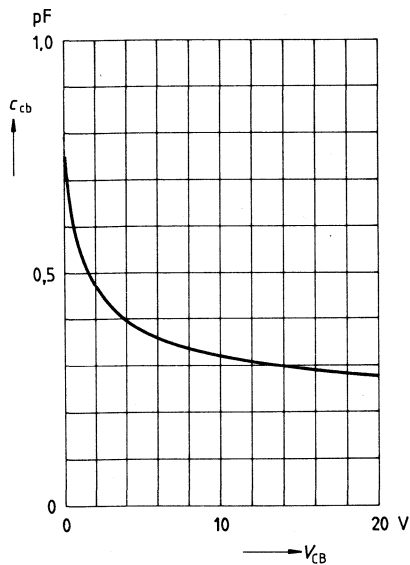

- For low-distortion, low-noise VHF/UHF amplifier and UHF oscillator applications in TV tuners
- Typical collector current 10 mA
- Miniature plastic package for surface mounting (SMD)

SOT 23

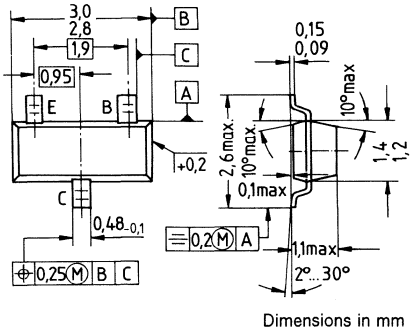

Type	BF 579	
Ordering code	bulk: Q62702-F552	taped: Q62702-F971
Marking	LJ	

Maximum ratings

Collector-emitter voltage	V_{CEO}	20	V
Collector-base voltage	V_{CBO}	25	V
Emitter-base voltage	V_{EBO}	3	V
Collector current	I_C	30	mA
Base current	I_B	5	mA
Total power dissipation ($T_A \leq 25^\circ\text{C}$)	P_{tot}	280	mW
Junction temperature	T_j	150	$^\circ\text{C}$
Storage temperature range	T_{stg}	-55... + 150	$^\circ\text{C}$

Thermal resistance

Junction — ambient	R_{thJA}	≤ 450	$\text{K/W}^{(1)}$
--------------------	------------	------------	--------------------

¹⁾ Package mounted on alumina 16.7 mm × 15 mm × 0.7 mm

Characteristics ($T_A = 25^\circ\text{C}$)

DC characteristics		min	typ	max	
Collector-emitter breakdown voltage $I_C = 1\text{ mA}, I_B = 0$	$V_{(BR)CE0}$	20	—	—	V
Collector cutoff current $V_{CB} = 20\text{ V}, I_E = 0$	I_{CBO}	—	—	100	nA
DC current gain $I_C = 10\text{ mA}, V_{CE} = 10\text{ V}$	h_{FE}	20	—	—	—
AC characteristics					
Transition frequency $I_C = 10\text{ mA}, V_{CE} = 10\text{ V}, f = 100\text{ MHz}$	f_T	—	1,6	—	GHz
Collector-base capacitance $V_{CB} = 10\text{ V}, V_{BE} = 0\text{ V}, f = 1\text{ MHz}$	C_{cb}	—	0,41	—	pF
Collector-emitter capacitance $V_{CE} = 10\text{ V}, V_{BE} = 0\text{ V}, f = 1\text{ MHz}$	C_{ce}	—	0,16	—	pF
Noise figure $I_C = 10\text{ mA}, V_{CB} = 10\text{ V}, R_S = 60\ \Omega$ $f = 800\text{ MHz}$ 200 MHz	F	—	4	—	dB
		—	2,9	—	dB
Common base power gain $I_C = 10\text{ mA}, V_{CB} = 10\text{ V}, f = 800\text{ MHz}$ $R_L = 500\ \Omega$	G_P	—	16	—	dB

Total power dissipation $P_{tot} = f(T_A)$

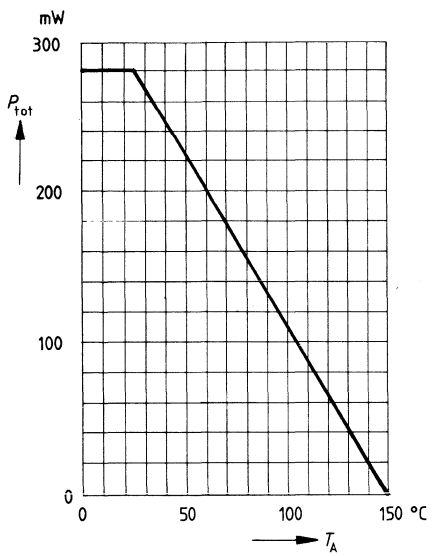

Transition frequency $f_T = f(I_C)$
 $V_{CE} = 10$ V, $f = 100$ MHz

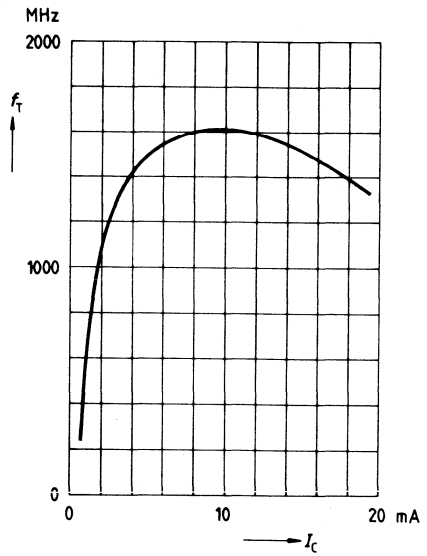

Collector-base capacitance $c_{cb} = f(V_{CB})$
 $f = 1$ MHz

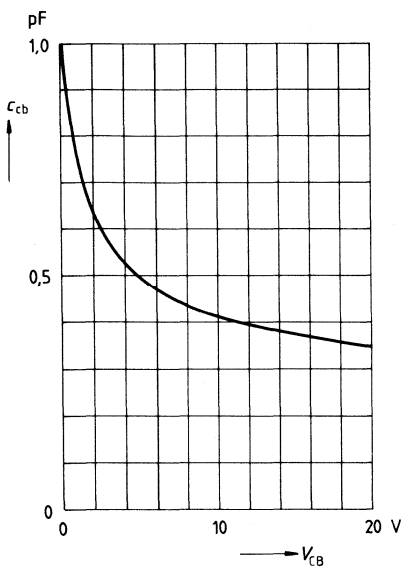

- Common emitter IF/RF amplifier
- Low feedback capacitance due to shield diffusion
- Miniature plastic package for surface mounting (SMD)

SOT 23

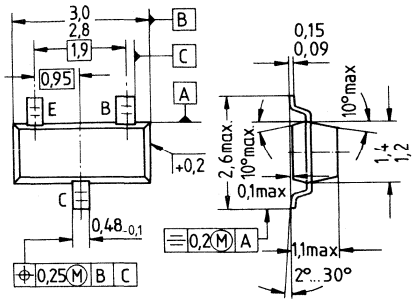

Dimensions in mm

Type	BF 599	
Ordering code	bulk: Q62702-F550	taped: Q62702-F979
Marking	NB	

Maximum ratings

Collector-emitter voltage	V_{CEO}	25	V
Collector-base voltage	V_{CBO}	40	V
Emitter-base voltage	V_{EBO}	4	V
Collector current	I_C	25	mA
Base current	I_B	5	mA
Total power dissipation ($T_A \leq 25^\circ\text{C}$)	P_{tot}	280	mW
Junction temperature	T_j	150	$^\circ\text{C}$
Storage temperature range	T_{stg}	-65... +150	$^\circ\text{C}$

Thermal resistance

Junction — ambient	R_{thJA}	≤ 450	$\text{K/W}^{(1)}$
--------------------	------------	------------	--------------------

¹⁾ Package mounted on alumina 16.7 mm × 15 mm × 0.7 mm

Characteristics ($T_A = 25^\circ\text{C}$)

DC characteristics		min	typ	max	
Collector-emitter breakdown voltage $I_C = 1\text{ mA}, I_B = 0$	$V_{(BR)CEO}$	25	—	—	V
Collector cutoff current $V_{CB} = 20\text{ V}, I_E = 0$	I_{CBO}	—	—	100	nA
DC current gain $I_C = 7\text{ mA}, V_{CE} = 10\text{ V}$	h_{FE}	38	70	—	—
Collector-emitter saturation voltage $I_C = 10\text{ mA}, I_B = 1\text{ mA}$	V_{CEsat}	—	0,15	—	V
Base-emitter voltage $I_C = 7\text{ mA}, V_{CE} = 10\text{ V}$	V_{BE}	—	0,78	—	V
AC characteristics					
Transition frequency $I_C = 5\text{ mA}, V_{CE} = 10\text{ V}, f = 100\text{ MHz}$	f_T	—	550	—	MHz
Collector-base capacitance $V_{CB} = 10\text{ V}, V_{BE} = 0\text{ V}, f = 1\text{ MHz}$	C_{cb}	—	0,35	—	pF
Collector-emitter capacitance $V_{CE} = 10\text{ V}, V_{BE} = 0\text{ V}, f = 1\text{ MHz}$	C_{ce}	—	0,68	—	pF
Optimum power gain $I_C = 7\text{ mA}, V_{CE} = 10\text{ V}, f = 35\text{ MHz}$	G_{peopt}	—	43	—	dB
Forward transfer admittance $I_C = 7\text{ mA}, V_{CE} = 10\text{ V}, f = 35\text{ MHz}$	$ y_{21e} $	—	175	—	mS

Total power dissipation $P_{tot} = f(T_A)$

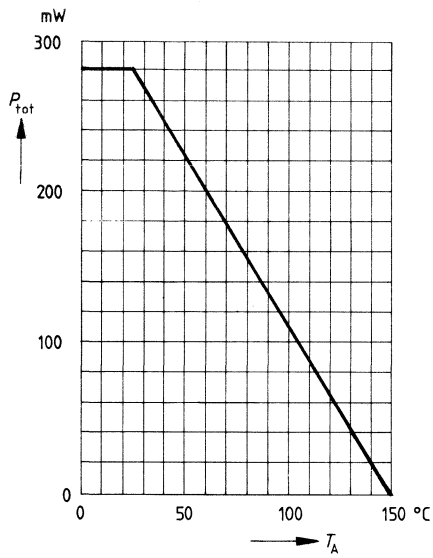

DC current gain $h_{FE} = f(I_C)$

$V_{CE} = 10\text{ V}$

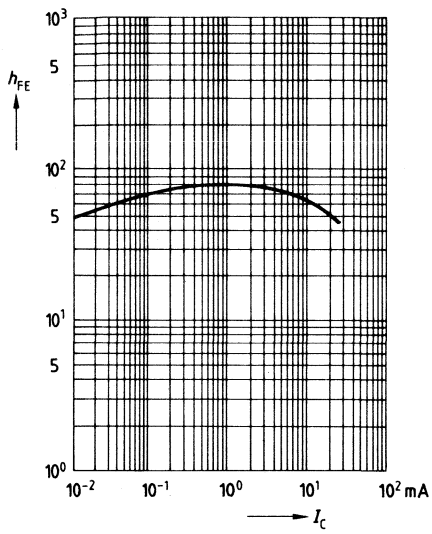

Collector current $I_C = f(V_{BE})$

$V_{CE} = 10\text{ V}$

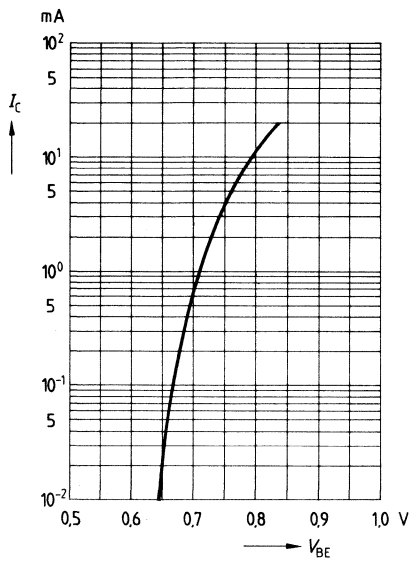

Collector-emitter saturation voltage

$V_{CEsat} = f(I_C)$

$h_{FE} = 10$

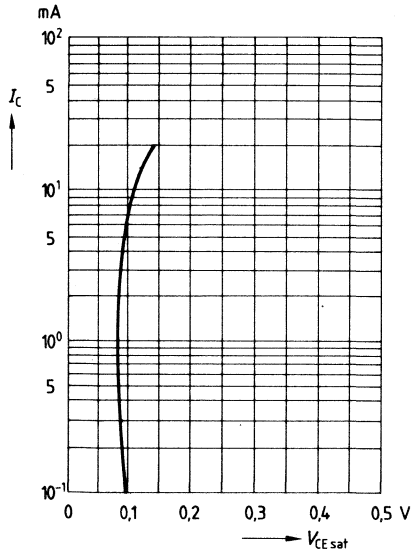

Collector cutoff current $I_{CBO} = f(T_A)$

$V_{CB} = 20\text{ V}$

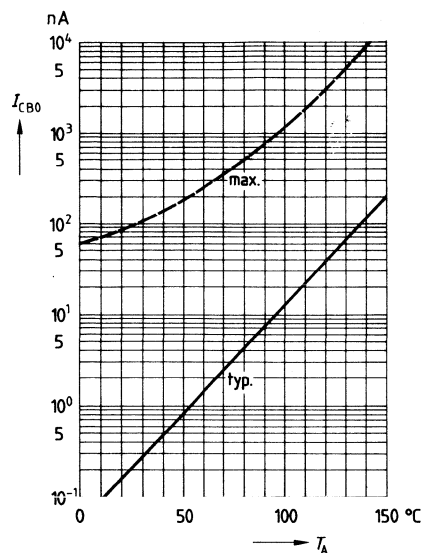

Transition frequency $f_T = f(I_C)$

$f = 100\text{ MHz}$

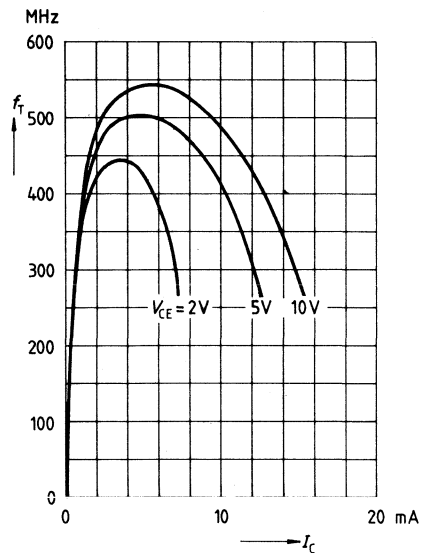

Collector-base capacitance $c_{cb} = f(V_{CB})$

$f = 1\text{ MHz}$

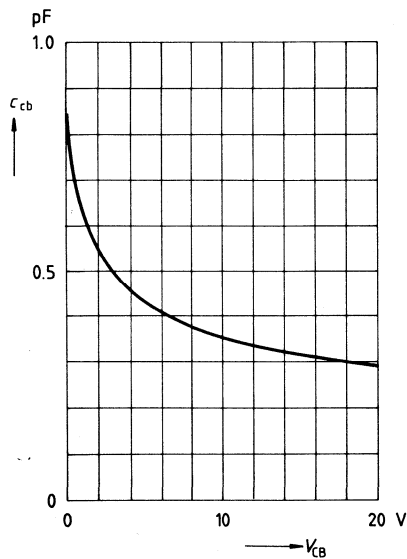

Forward transfer admittance $|y_{21e}| = f(I_C)$

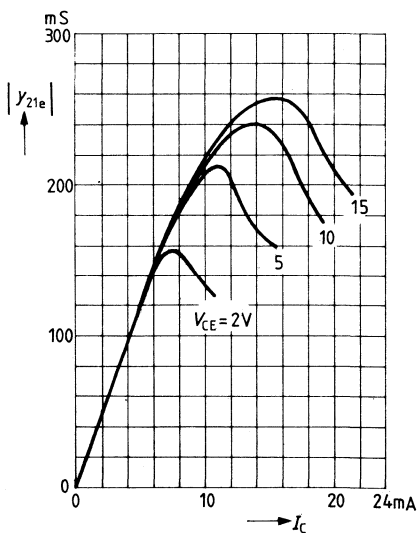

- For VHF oscillator stages

TO 92

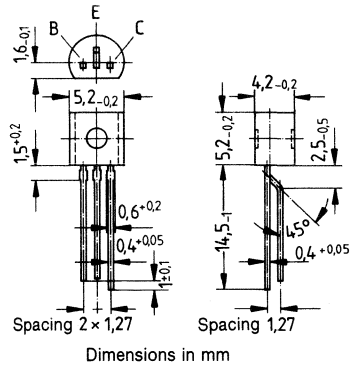

Type	BF 606 A
Ordering code	Q62702-F535

Maximum ratings

Collector-emitter voltage	V_{CEO}	30	V
Collector-base voltage	V_{CBO}	40	V
Emitter-base voltage	V_{EBO}	4	V
Collector current	I_C	25	mA
Emitter current	I_E	30	mA
Total power dissipation ($T_A \leq 45^\circ\text{C}$)	P_{tot}	300	mW
Junction temperature	T_j	150	$^\circ\text{C}$
Storage temperature range	T_{stg}	-55... + 150	$^\circ\text{C}$

Thermal resistance

Junction — ambient	R_{thJA}	≤ 350	K/W
--------------------	------------	------------	-----

Characteristics ($T_A = 25^\circ\text{C}$)

DC characteristics

		min	typ	max	
Collector-emitter breakdown voltage $I_C = 2\text{ mA}$	$V_{(BR)CEO}$	30	—	—	V
Collector-base breakdown voltage $I_C = 10\ \mu\text{A}$	$V_{(BR)CBO}$	40	—	—	V
Emitter-base breakdown voltage $I_E = 10\ \mu\text{A}$	$V_{(BR)EBO}$	4	—	—	V
Collector cutoff current $V_{CB} = 20\text{ V}$	I_{CBO}	—	—	60	nA
DC current gain $I_C = 1\text{ mA}, V_{CE} = 10\text{ V}$	h_{FE}	30	—	—	—

AC characteristics

Transition frequency $I_C = 5\text{ mA}, V_{CE} = 10\text{ V}, f = 100\text{ MHz}$	f_T	—	700	—	MHz
Collector-emitter capacitance $V_{CE} = 10\text{ V}, V_{BE} = 0\text{ V}, f = 1\text{ MHz}$	C_{ce}	—	0,35	—	pF
Collector-base capacitance $V_{CB} = 10\text{ V}, V_{BE} = 0\text{ V}, f = 1\text{ MHz}$	C_{cb}	—	—	0,85	pF

- For VHF oscillator applications
- Miniature plastic package for surface mounting (SMD)

SOT 23

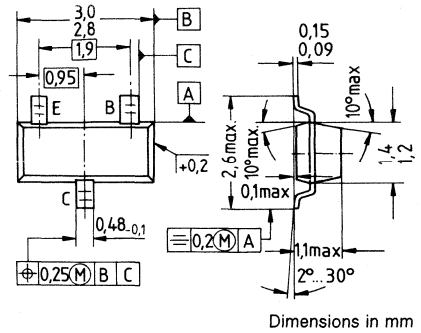

Type	BF 660	
Ordering code	bulk: Q62702-F549	taped: Q62702-F982
Marking	LE	

Maximum ratings

Collector-emitter voltage	V_{CEO}	30	V
Collector-base voltage	V_{CBO}	40	V
Emitter-base voltage	V_{EBO}	4	V
Collector current	I_C	25	mA
Emitter current	I_E	30	mA
Total power dissipation ($T_A \leq 25^\circ C$)	P_{tot}	280	mW
Junction temperature	T_j	150	$^\circ C$
Storage temperature range	T_{stg}	- 65... + 150	$^\circ C$

Thermal resistance

Junction — ambient	R_{thJA}	≤ 450	$ K/W^{1)}$
--------------------	------------	------------	--------------

¹⁾ Package mounted on alumina 16.7 mm x 15 mm x 0.7 mm

Characteristics ($T_A = 25^\circ\text{C}$)

DC characteristics		min	typ	max	
Collector-emitter breakdown voltage $I_C = 1\text{ mA}, I_E = 0$	$V_{(BR)CEO}$	30	—	—	V
Collector-base breakdown voltage $I_C = 10\text{ }\mu\text{A}, I_E = 0$	$V_{(BR)CBO}$	40	—	—	V
Emitter-base breakdown voltage $I_E = 10\text{ }\mu\text{A}, I_C = 0$	$V_{(BR)EBO}$	4	—	—	V
Collector cutoff current $V_{CB} = 20\text{ V}, I_E = 0$	I_{CBO}	—	—	50	nA
DC current gain $I_C = 3\text{ mA}, V_{CE} = 10\text{ V}$	h_{FE}	30	—	—	—

AC characteristics

AC characteristics					
Transition frequency $I_C = 5\text{ mA}, V_{CE} = 10\text{ V}, f = 100\text{ MHz}$	f_T	—	700	—	MHz
Collector-base capacitance $V_{CB} = 10\text{ V}, V_{BE} = 0\text{ V}, f = 1\text{ MHz}$	C_{cb}	—	0,6	—	pF
Collector-emitter capacitance $V_{CE} = 10\text{ V}, V_{BE} = 0\text{ V}, f = 1\text{ MHz}$	C_{ce}	—	0,28	—	pF

Total power dissipation $P_{tot} = f(T_A)$

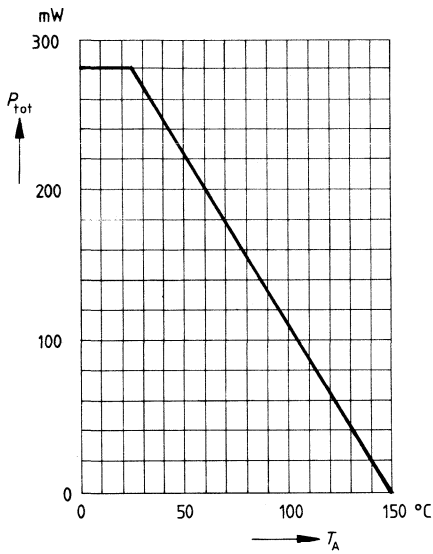

Transition frequency $f_T = f(I_C)$

$V_{CE} = 10 \text{ V}, f = 100 \text{ MHz}$

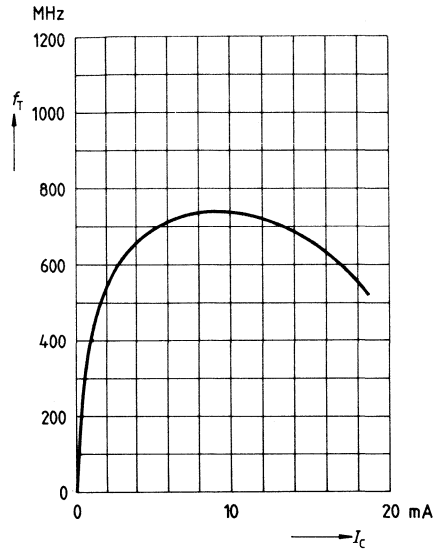

Collector-base capacitance $c_{cb} = f(V_{CB})$

$f = 1 \text{ MHz}$

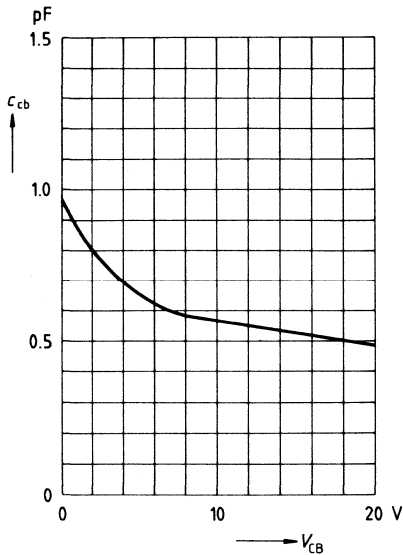

- For low-noise amplifiers and oscillators up to 1 GHz

TO 92

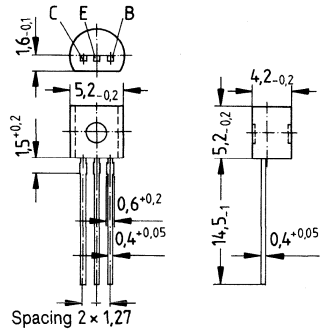

Dimensions in mm

Type	BF 763
Ordering code	Q62702-F766

Maximum ratings

Collector-emitter voltage
 Collector-base voltage
 Emitter-base voltage
 Collector current
 Total power dissipation
 ($T_A \leq 25^\circ\text{C}$)
 Junction temperature
 Storage temperature range

V_{CE0}	15	V
V_{CBO}	25	V
V_{EBO}	3,5	V
I_C	25	mA
P_{tot}	500	mW
T_j	150	$^\circ\text{C}$
T_{stg}	-55... +150	$^\circ\text{C}$

Thermal resistance

Junction — ambient

R_{thJA}	≤ 250	K/W
------------	------------	-----

Characteristics ($T_A = 25^\circ\text{C}$)**DC characteristics**

		min	typ	max	
Collector-emitter breakdown voltage $I_C = 1\text{ mA}$	$V_{(BR)CEO}$	15	—	—	V
Collector-base breakdown voltage $I_C = 10\ \mu\text{A}$	$V_{(BR)CBO}$	25	—	—	V
Emitter-base breakdown voltage $I_E = 10\ \mu\text{A}$	$V_{(BR)EBO}$	3,5	—	—	V
Collector cutoff current $V_{CB} = 15\text{ V}$	I_{CBO}	—	—	50	nA
DC current gain $I_C = 5\text{ mA}$, $V_{CE} = 10\text{ V}$	h_{FE}	25	—	250	—
Collector-emitter saturation voltage $I_C = 10\text{ mA}$, $I_B = 1\text{ mA}$	V_{CEsat}	—	—	0,5	V

AC characteristics

Transition frequency $I_C = 5\text{ mA}$, $V_{CE} = 10\text{ V}$, $f = 200\text{ MHz}$	f_T	—	2000	—	MHz
Collector-base capacitance $V_{CB} = 10\text{ V}$, $V_{BE} = 0\text{ V}$, $f = 1\text{ MHz}$	c_{cb}	0,3	—	0,9	pF
Noise figure $I_C = 5\text{ mA}$, $V_{CE} = 10\text{ V}$, $R_s = 60\ \Omega$ $f = 200\text{ MHz}$ 800 MHz	F	—	2,5 5	—	dB dB

- Low-noise broadband transistor for frequencies up to 2 GHz at collector currents up to 30 mA
- For IF amplifiers in TV-sat tuners and for VCR modulators
- Miniature plastic package for surface mounting (SMD)

SOT 23

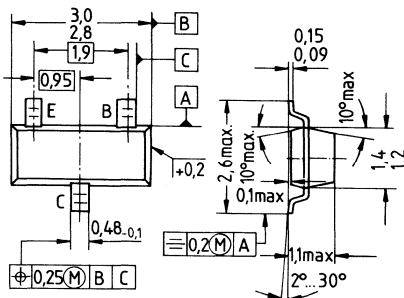

Dimensions in mm

Type	BF 770 A	
Ordering code	bulk: Q62702-F1068	taped: Q62702-F1080
Marking	LS	

Maximum ratings

Collector-emitter voltage	V_{CEO}	12	V
Collector-base voltage	V_{CBO}	15	V
Emitter-base voltage	V_{EBO}	2	V
Collector current	I_C	50	mA
Base current	I_B	10	mA
Total power dissipation ($T_A \leq 25^\circ\text{C}$)	P_{tot}	280	mW
Junction temperature	T_j	150	$^\circ\text{C}$
Storage temperature range	T_{stg}	-65... + 150	$^\circ\text{C}$

Thermal resistance

Junction — ambient	R_{thJA}	≤ 450	$\text{K/W}^{1)}$
--------------------	------------	------------	-------------------

¹⁾ Package mounted on alumina 16.7 mm × 15 mm × 0.7 mm

Characteristics ($T_A = 25^\circ\text{C}$)**DC characteristics**

		min	typ	max	
Collector-emitter breakdown voltage $I_C = 1\text{ mA}, I_B = 0$	$V_{(BR)CEO}$	12	—	—	V
Collector cutoff current $V_{CB} = 5\text{ V}, I_E = 0$	I_{CBO}	—	—	50	nA
DC current gain $I_C = 30\text{ mA}, V_{CE} = 5\text{ V}$	h_{FE}	40	90	—	—
Collector-emitter saturation voltage $I_C = 50\text{ mA}, I_B = 5\text{ mA}$	V_{CEsat}	—	0,13	0,5	V

AC characteristics

Transition frequency $I_C = 30\text{ mA}, V_{CE} = 5\text{ V}, f = 200\text{ MHz}$	f_T	—	5,5	—	GHz
Collector-base capacitance $V_{CB} = 5\text{ V}, V_{BE} = 0\text{ V}, f = 1\text{ MHz}$	C_{cb}	—	0,6	—	pF
Collector-emitter capacitance $V_{CE} = 5\text{ V}, V_{BE} = 0\text{ V}, f = 1\text{ MHz}$	C_{ce}	—	0,3	—	pF
Noise figure $I_C = 10\text{ mA}, V_{CE} = 5\text{ V}, f = 800\text{ MHz}$	F	—	2	—	dB
Power gain $I_C = 30\text{ mA}, V_{CB} = 5\text{ V}, f = 800\text{ MHz}$	G_p	—	13	—	dB

Total power dissipation $P_{tot} = f(T_A)$

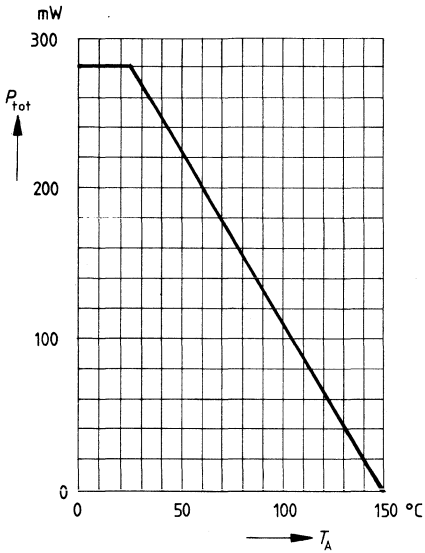

Transition frequency $f_T = f(I_C)$

$V_{CE} = 5\text{ V}, f = 200\text{ MHz}$

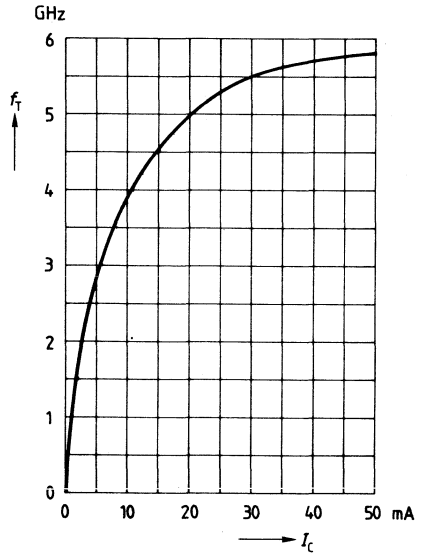

Collector-base capacitance $c_{cb} = f(V_{CB})$

$f = 1\text{ MHz}$

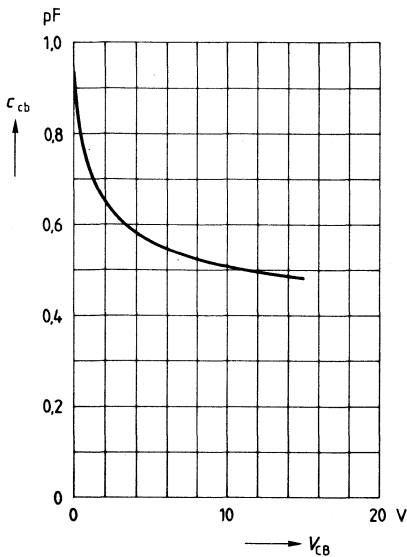

Noise figure $F = f(I_C)$

$V_{CE} = 8\text{ V}$

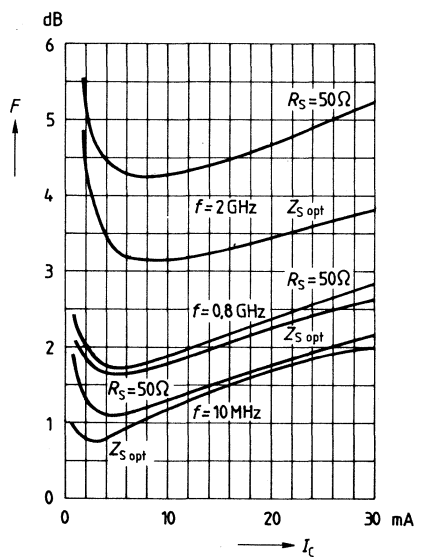

- For broadband applications up to 2 GHz
- Especially for RF amplifiers, mixers, and oscillators in TV-sat tuners
- Miniature plastic package for surface mounting (SMD)

SOT 23

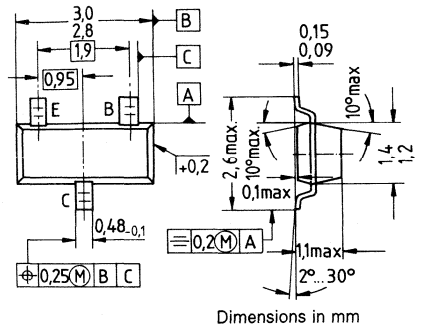

Type	BF 775	
Ordering code	bulk: Q62702-F991	taped: Q62702-F102
Marking	LO	

Maximum ratings

Collector-emitter voltage	V_{CEO}	12	V
Collector-base voltage	V_{CBO}	20	V
Emitter-base voltage	V_{EBO}	2,5	V
Collector current	I_C	30	mA
Base current	I_B	4	mA
Total power dissipation ($T_A \leq 25^\circ\text{C}$)	P_{tot}	280	mW
Junction temperature	T_j	150	$^\circ\text{C}$
Storage temperature range	T_{stg}	-65... + 150	$^\circ\text{C}$

Thermal resistance

Junction — ambient	R_{thJA}	≤ 450	$ \text{K/W}^1)$
--------------------	------------	------------	-------------------

¹⁾ Package mounted on alumina 16.7 mm × 15 mm × 0.7 mm

Characteristics ($T_A = 25^\circ\text{C}$)

DC characteristics		min	typ	max	
Collector-emitter breakdown voltage $I_C = 1\text{ mA}, I_B = 0$	$V_{(BR)_{CEO}}$	12	—	—	V
Collector cutoff current $V_{CB} = 10\text{ V}, I_E = 0$	I_{CBO}	—	—	50	nA
DC current gain, $V_{CE} = 6\text{ V}$ $I_C = 5\text{ mA}$ 20 mA	h_{FE}	40	90	250	—
		40	100	—	—
Collector-emitter saturation voltage $I_C = 20\text{ mA}, I_B = 2\text{ mA}$	V_{CEsat}	—	0,16	0,5	V

AC characteristics

Transition frequency $I_C = 5\text{ mA}, V_{CE} = 6\text{ V}, f = 200\text{ MHz}$ 20 mA 6 V 200 MHz	f_T	—	3,5	—	GHz
		—	4,5	—	GHz
Collector-base capacitance $V_{CB} = 6\text{ V}, V_{BE} = 0\text{ V}, f = 1\text{ MHz}$	C_{cb}	—	0,58	—	pF
Collector-emitter capacitance $V_{CE} = 10\text{ V}, V_{BE} = 0\text{ V}, f = 1\text{ MHz}$	C_{ce}	—	0,27	—	pF
Noise figure $I_C = 2\text{ mA}, V_{CE} = 6\text{ V}, f = 800\text{ MHz}$	F	—	2,1	—	dB

Total power dissipation $P_{tot} = f(T_A)$

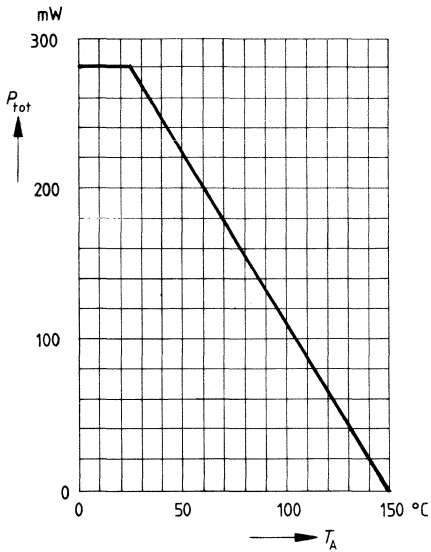

Transition frequency $f_T = f(I_C)$

$V_{CE} = 6\text{ V}, f = 200\text{ MHz}$

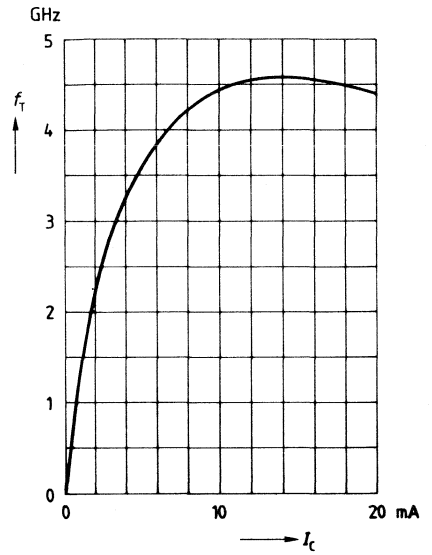

Collector-base capacitance $c_{cb} = f(V_{CB})$

$f = 1\text{ MHz}$

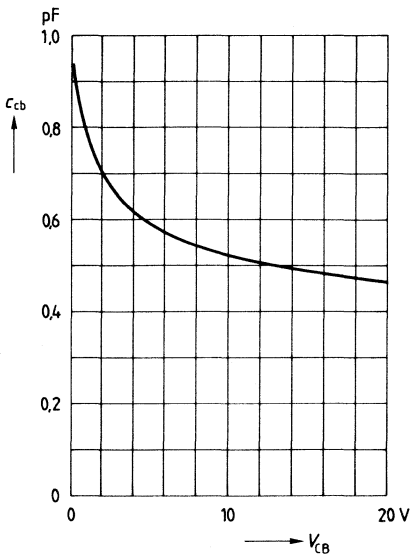

- For linear broadband amplifier applications up to 500 MHz
- SAW filter driver in TV tuners
- Miniature plastic package for surface mounting (SMD)

SOT 23

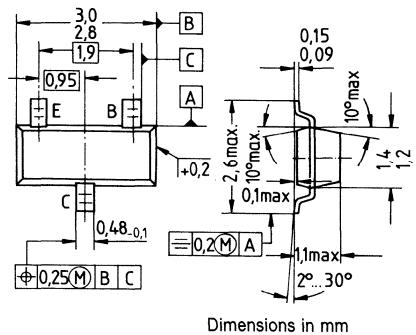

Type	BF 799	
Ordering code	bulk: Q62702-F788	taped: Q62702-F935
Marking	LK	

Maximum ratings

Collector-emitter voltage	V_{CE0}	20	V
Collector-emitter reverse voltage	V_{CES}	30	V
Collector-base voltage	V_{CBO}	30	V
Emitter-base voltage	V_{EBO}	3	V
Collector current	I_C	35	mA
Peak collector current	I_{CM}	50	mA
Peak base current	I_{BM}	15	mA
Total power dissipation ($T_A \leq 25^\circ\text{C}$)	P_{tot}	280	mW
Junction temperature	T_j	150	$^\circ\text{C}$
Storage temperature range	T_{stg}	-65... +150	$^\circ\text{C}$

Thermal resistance

Junction — ambient	R_{thJA}	≤ 450	$ \text{K/W}^{(1)}$
--------------------	------------	------------	----------------------

¹⁾ Package mounted on alumina 16.7 mm × 15 mm × 0.7 mm

Characteristics ($T_A = 25^\circ\text{C}$)

DC characteristics		min	typ	max	
Collector-emitter breakdown voltage $I_C = 1\text{ mA}, I_B = 0$	$V_{(BR)CE0}$	20	—	—	V
Collector-base breakdown voltage $I_C = 10\ \mu\text{A}, I_E = 0$	$V_{(BR)CBO}$	30	—	—	V
Emitter-base breakdown voltage $I_E = 10\ \mu\text{A}$	$V_{(BR)EBO}$	3	—	—	V
Collector cutoff current $V_{CB} = 20\text{ V}$	I_{CBO}	—	—	100	nA
DC current gain, $V_{CE} = 10\text{ V}$ $I_C = 5\text{ mA}$ 20 mA	h_{FE}	35 40	95 100	— 250	— —
Collector-emitter saturation voltage $I_C = 20\text{ mA}, I_B = 2\text{ mA}$	V_{CEsat}	—	0,15	0,5	V
Base-emitter saturation voltage $I_C = 20\text{ mA}, I_B = 2\text{ mA}$	V_{BEsat}	—	—	0,95	V

AC characteristics

Transition frequency $I_C = 5\text{ mA}, V_{CE} = 10\text{ V}, f = 100\text{ MHz}$ $20\text{ mA}, 8\text{ V}, 100\text{ MHz}$	f_T	— —	800 1100	— —	MHz MHz
Output capacitance $V_{CB} = 10\text{ V}, f = 1\text{ MHz}, I_E = 0$	C_{ob}	—	0,96	—	pF
Collector-base capacitance $V_{CB} = 10\text{ V}, V_{BE} = 0\text{ V}, f = 1\text{ MHz}$	C_{cb}	—	0,7	—	pF
Collector-emitter capacitance $V_{CE} = 10\text{ V}, V_{BE} = 0\text{ V}, f = 1\text{ MHz}$	C_{ce}	—	0,28	—	pF
Noise figure $I_C = 5\text{ mA}, V_{CE} = 10\text{ V}, f = 100\text{ MHz}$ $R_S = 50\ \Omega$	F	—	3	—	dB
Output conductance $I_C = 20\text{ mA}, V_{CE} = 10\text{ V}, f = 35\text{ MHz}$	g_{22e}	—	60	—	μS

Total power dissipation $P_{\text{tot}} = f(T_A)$

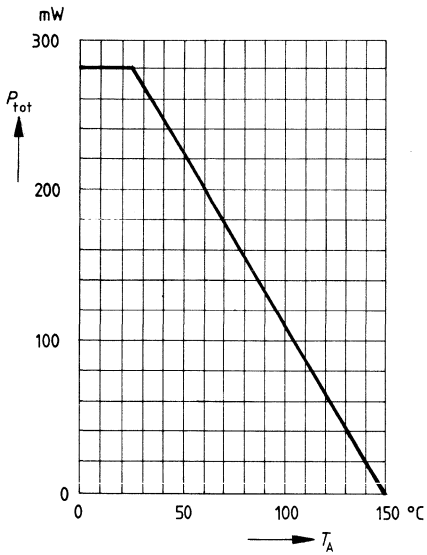

Transition frequency $f_T = f(I_C)$
 $f = 100$ MHz

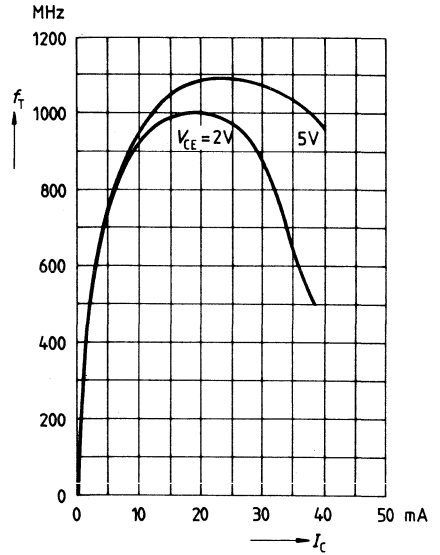

Collector-base capacitance $c_{cb} = f(V_{CB})$
 $f = 1$ MHz

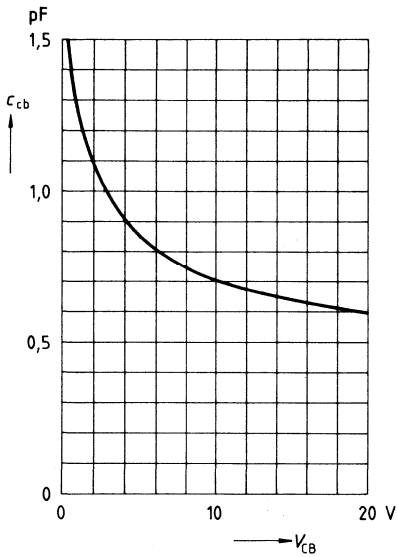

- For SAW filter driver applications in TV tuners
- For linear broadband VHF amplifier stages
- For oscillator applications

TO 92

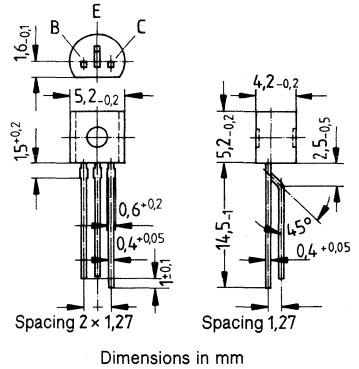

Type	BF 959
Ordering code	Q62702-F640

Maximum ratings

Collector-emitter voltage	V_{CE0}	20	V
Collector-emitter reverse voltage	V_{CES}	30	V
Collector-base voltage	V_{CBO}	30	V
Emitter-base voltage	V_{EBO}	3	V
Peak collector current	I_{CM}	100	mA
Peak base current	I_{BM}	30	mA
Total power dissipation ($T_A \leq 25^\circ\text{C}$, $V_{CE} \leq 15\text{ V}$)	P_{tot}	500	mW
Junction temperature	T_j	150	$^\circ\text{C}$
Storage temperature range	T_{stg}	- 55... + 150	$^\circ\text{C}$

Thermal resistance

Junction — ambient	R_{thJA}	≤ 250	K/W
--------------------	------------	------------	-----

Characteristics ($T_A = 25^\circ\text{C}$)

DC characteristics		min	typ	max	
Collector-emitter breakdown voltage $I_C = 1\text{ mA}$	$V_{(BR)CEO}$	20	—	—	V
Collector-base breakdown voltage $I_C = 10\ \mu\text{A}$	$V_{(BR)CBO}$	30	—	—	V
Emitter-base breakdown voltage $I_E = 10\ \mu\text{A}$	$V_{(BR)EBO}$	3	—	—	V
Collector cutoff current $V = 20\text{ V}$	I_{CBO}	—	—	100	nA
DC current gain, $V_{CE} = 10\text{ V}$ $I_C = 5\text{ mA}$ 20 mA	h_{FE}	35 40	— 85	— —	— —
Base-emitter voltage $I_C = 20\text{ mA}$, $V_{CE} = 10\text{ V}$	V_{BE}	—	0,75	—	V
Collector-emitter saturation voltage $I_C = 30\text{ mA}$, $I_B = 2\text{ mA}$	V_{CEsat}	—	—	1	V
Base-emitter saturation voltage $I_C = 30\text{ mA}$, $I_B = 2\text{ mA}$	V_{BEsat}	—	—	0,95	V

AC characteristics

Transition frequency $I_C = 20\text{ mA}$, $V_{CE} = 10\text{ V}$, $f = 100\text{ MHz}$ 30 mA, 5 V	f_T	700 600	1100 —	— —	MHz MHz
Output capacitance $V_{CB} = 10\text{ V}$, $I_E = 0$, $f = 1\text{ MHz}$	C_{obo}	—	0,9	—	pF
Collector-base capacitance $V_{CE} = 10\text{ V}$, $V_{BE} = 0$, $f = 1\text{ MHz}$	C_{cb}	—	0,75	—	pF
Noise figure $V_{CE} = 10\text{ V}$, $f = 200\text{ MHz}$, $R_s = 60\ \Omega$ $I_C = 5\text{ mA}$ 20 mA	F	— —	3 4	— —	dB dB
Output conductance $I_C = 20\text{ mA}$, $V_{CE} = 10\text{ V}$, $f = 35\text{ MHz}$	g_{22e}	—	0,06	—	mS

Total power dissipation $P_{\text{tot}} = f(T_A)$

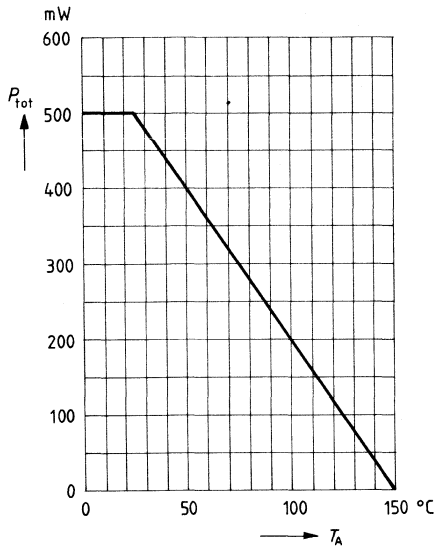

Transition frequency $f_T = f(I_C)$
 $f = 100 \text{ MHz}$

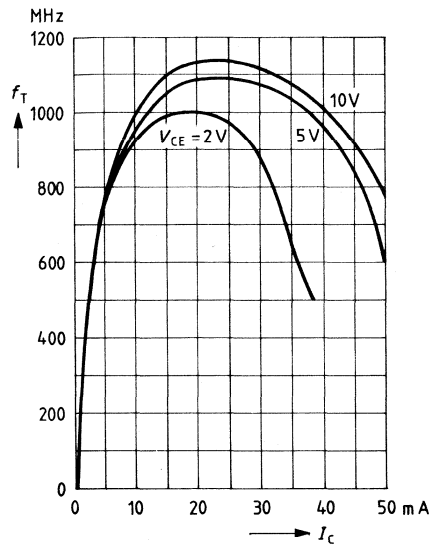

Collector-base capacitance $c_{cb} = f(V_{CB})$
 $f = 1 \text{ MHz}$

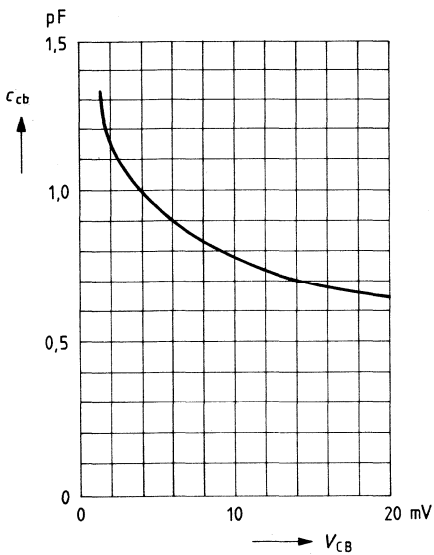

- For amplifier and mixer stages up to 1 GHz in UHF and VHF TV tuners
- Low input and output capacitance

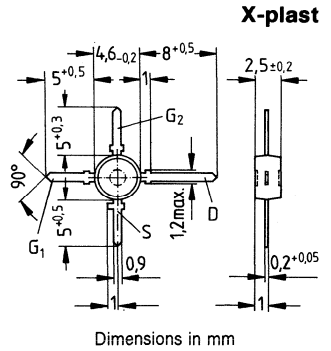

Type	BF 960
Ordering code	Q62702-F499

Maximum ratings

Drain-source voltage	V_{DS}	20	V
Drain current	I_D	30	mA
Gate 1/gate 2 peak source current	$\pm I_{G1/2SM}$	10	mA
Total power dissipation $T_A \leq 60^\circ C$	P_{tot}	200	mW
Storage temperature range	T_{stg}	- 55 ... + 150	$^\circ C$
Channel temperature	T_{Ch}	150	$^\circ C$

Thermal resistance

Junction — ambient	T_{thJA}	≤ 450	K/W
--------------------	------------	------------	-----

Characteristics ($T_A = 25^\circ\text{C}$)

DC characteristics

		min	typ	max	
Drain-source breakdown voltage $I_D = 10\ \mu\text{A}$, $-V_{G1S} = -V_{G2S} = 4\ \text{V}$	$V_{(BR)DS}$	20	—	—	V
Gate 1 source breakdown voltage $\pm I_{G1S} = 10\ \text{mA}$, $V_{G2S} = V_{DS} = 0$	$\pm V_{(BR)G1SS}$	8,5	—	17	V
Gate 2 source breakdown voltage $\pm I_{G2S} = 10\ \text{mA}$, $V_{G1S} = V_{DS} = 0$	$\pm V_{(BR)G2SS}$	8,5	—	17	V
Gate 1 source leakage current $\pm V_{G1S} = 5\ \text{V}$, $V_{G2S} = V_{DS} = 0$	$\pm I_{G1SS}$	—	—	50	nA
Gate 2 source leakage current $\pm V_{G2S} = 5\ \text{V}$, $V_{G1S} = V_{DS} = 0$	$\pm I_{G2SS}$	—	—	50	nA
Drain current $V_{DS} = 15\ \text{V}$, $V_{G1S} = 0$, $V_{G2S} = 4\ \text{V}$	I_{DSS}	2	—	20	mA
Gate 1 source pinch-off voltage $V_{DS} = 15\ \text{V}$, $V_{G2S} = 4\ \text{V}$, $I_D = 20\ \mu\text{A}$	$-V_{G1S(p)}$	—	—	2,7	V
Gate 2 source pinch-off voltage $V_{DS} = 15\ \text{V}$, $V_{G1S} = 0$, $I_D = 20\ \mu\text{A}$	$-V_{G2S(p)}$	—	—	2,7	V

Characteristics ($T_A = 25^\circ\text{C}$)

AC characteristics		min	typ	max	
Forward transconductance $V_{DS} = 15\text{ V}, I_D = 7\text{ mA}, V_{G2S} = 4\text{ V}, f = 1\text{ kHz}$	g_{fs}	9,5	12	—	mS
Gate 1 input capacitance $V_{DS} = 15\text{ V}, I_D = 7\text{ mA}, V_{G2S} = 4\text{ V}, f = 1\text{ MHz}$	C_{g1ss}	—	1,8	—	pF
Gate 2 input capacitance $V_{DS} = 15\text{ V}, I_D = 7\text{ mA}, V_{G2S} = 4\text{ V}, f = 1\text{ MHz}$	C_{g2ss}	—	1	—	pF
Feedback capacitance $V_{DS} = 15\text{ V}, I_D = 7\text{ mA}, V_{G2S} = 4\text{ V}, f = 1\text{ MHz}$	C_{dg1}	—	25	—	fF
Output capacitance $V_{DS} = 15\text{ V}, I_D = 7\text{ mA}, V_{G2S} = 4\text{ V}, f = 1\text{ MHz}$	C_{dss}	—	0,8	—	pF
Power gain $V_{DS} = 15\text{ V}, I_D = 7\text{ mA},$ $f = 200\text{ MHz}, G_G = 2\text{ mS}, G_L = 0,5\text{ mS}$ (test circuit 1)	G_{ps}	—	23	—	dB
$f = 800\text{ MHz}, G_G = 3,3\text{ mS}, G_L = 1\text{ mS}$ (test circuit 2)		—	16,5	—	dB
Noise figure $V_{DS} = 15\text{ V}, I_D = 7\text{ mA},$ $f = 200\text{ MHz}, G_G = 2\text{ mS}, G_L = 0,5\text{ mS}$ (test circuit 1)	F	—	1,6	—	dB
$f = 800\text{ MHz}, G_G = 3,3\text{ mS}, G_L = 1\text{ mS}$ (test circuit 2)		—	2,8	—	dB
Gain control range $V_{DS} = 15\text{ V}, V_{G2S} = 4 \dots -2\text{ V}, f = 800\text{ MHz}$	ΔG_{ps}	40	—	—	dB
Mixer gain $V_{DS} = 15\text{ V}, V_{G2S} = 4\text{ V}, f = 800\text{ MHz}$ $f_{IF} = 36\text{ MHz}, 2 \Delta f_{IF} = 5\text{ MHz}, V_{osc} = 800\text{ mV}$ (test circuit 3)	G_{psc}	—	16	—	dB

Total power dissipation $P_{tot} = f(T_A)$

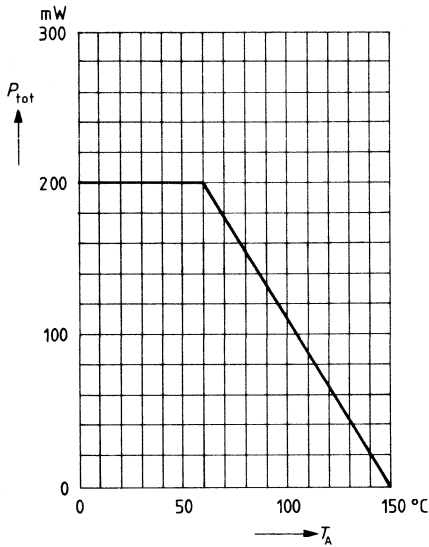

Output characteristics $I_D = f(V_{DS})$

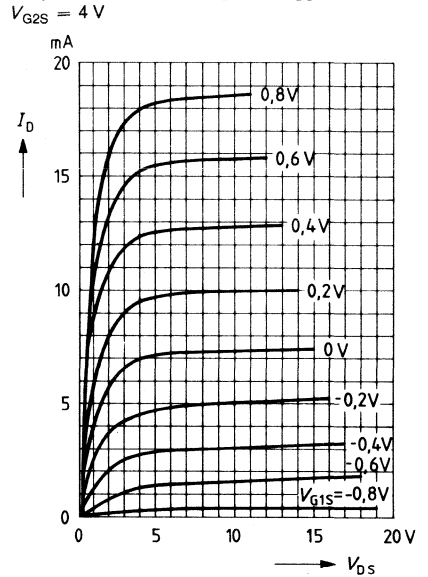

Gate 1 forward transconductance

$g_{fs1} = f(V_{G1S})$
 $V_{DS} = 15\text{ V}$
 $I_{DSS} = 7\text{ mA}, f = 1\text{ kHz}$

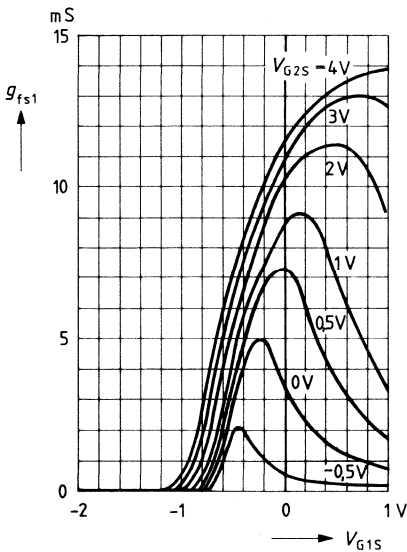

Gate 2 forward transconductance

$g_{fs2} = f(V_{G2S})$
 $V_{DS} = 15\text{ V}$
 $I_{DSS} = 7\text{ mA}, f = 1\text{ kHz}$

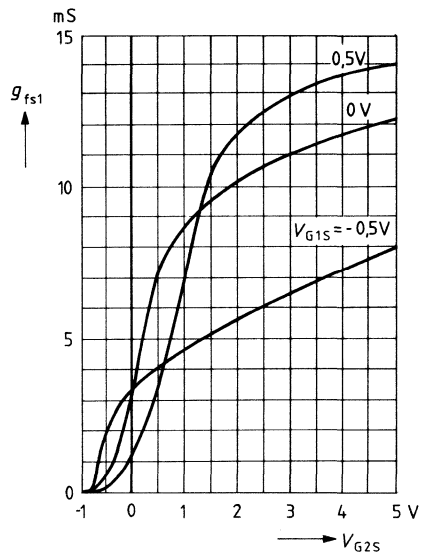

Drain current $I_D = f(V_{G1S})$

$V_{DS} = 15\text{ V}$

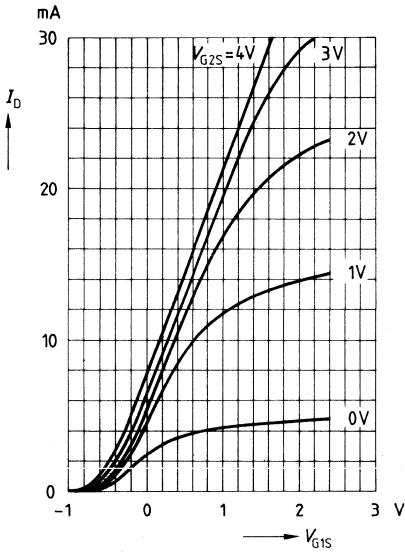

Gate 1 input capacitance $c_{g1ss} = f(V_{G1S})$

$V_{G2S} = 4\text{ V}, V_{DS} = 15\text{ V}$

$I_{DSS} = 7\text{ mA}, f = 1\text{ MHz}$

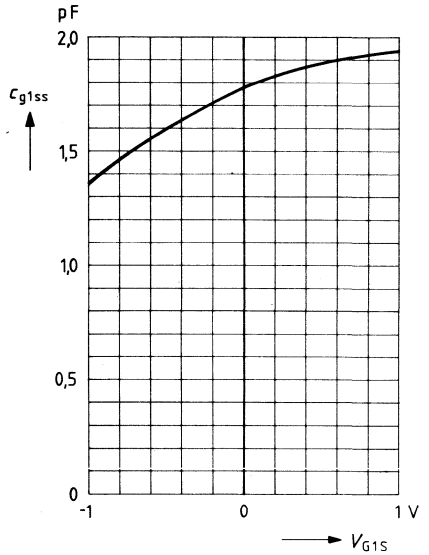

Gate 2 input capacitance $c_{g2ss} = f(V_{G2S})$

$V_{G1S} = 0\text{ V}, V_{DS} = 15\text{ V}$

$I_{DSS} = 7\text{ mA}, f = 1\text{ MHz}$

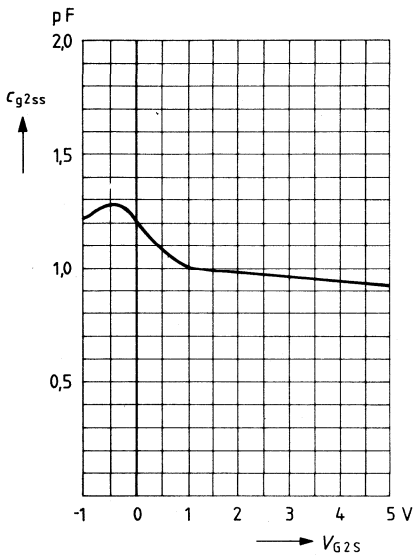

Output capacitance $c_{dss} = f(V_{DS})$

$V_{G1S} = 0\text{ V}, V_{G2S} = 4\text{ V}$

$I_{DSS} = 7\text{ mA}, f = 1\text{ MHz}$

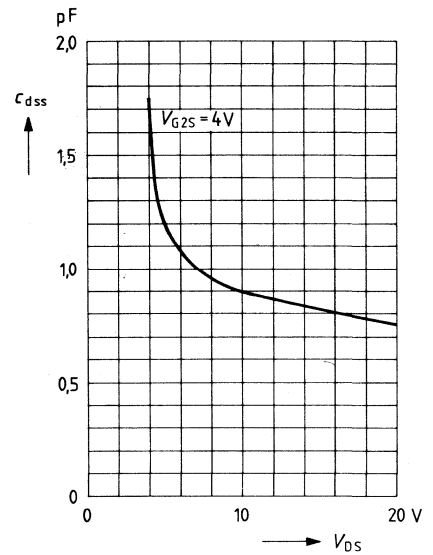

Gate 1 input admittance y_{11s}

$V_{DS} = 15\text{ V}$, $V_{G2S} = 4\text{ V}$

(common source)

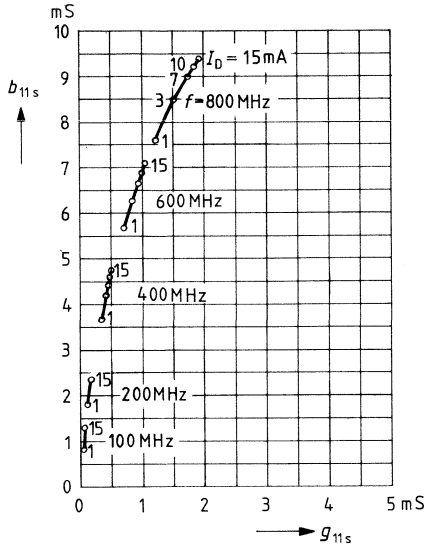

Gate 1 forward transfer admittance y_{21s}

$V_{DS} = 15\text{ V}$, $V_{G2S} = 4\text{ V}$

(common source)

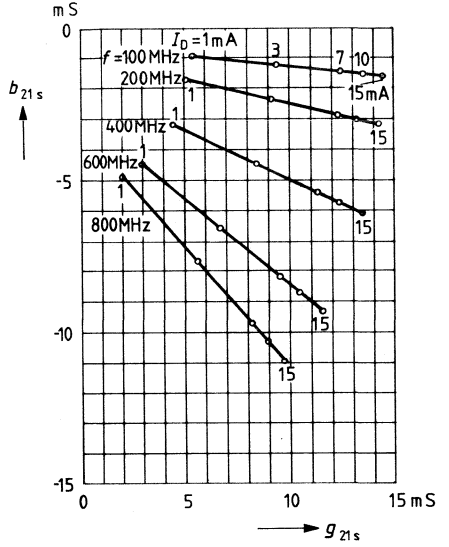

Output admittance y_{22s}

$V_{DS} = 15\text{ V}$, $V_{G2S} = 4\text{ V}$

(common source)

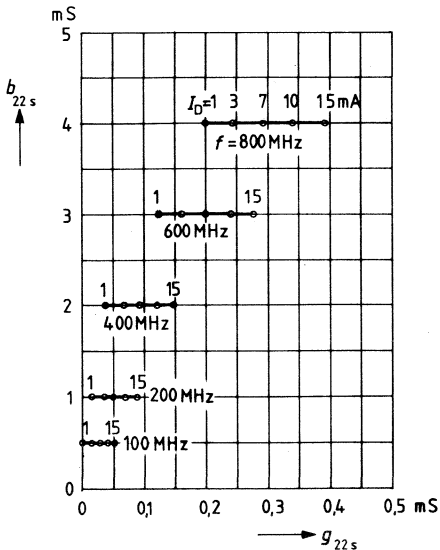

Power gain $G_{ps} = f(V_{G2S})$

$V_{DS} = 15\text{ V}$, $V_{G1S} = 0$, $I_{DSS} = 7\text{ mA}$
 $f = 200\text{ MHz}$ (see test circuit 1)

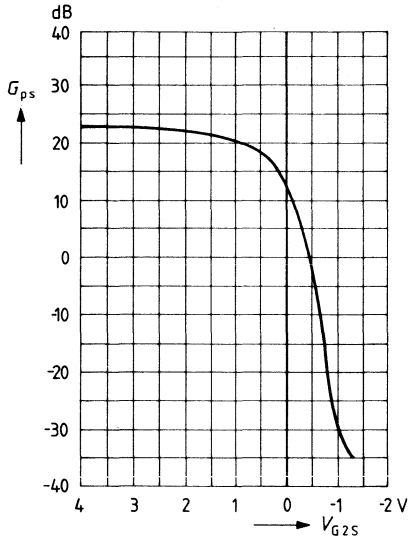

Noise figure $F = f(V_{G2S})$

$V_{DS} = 15\text{ V}$, $V_{G1S} = 0$, $I_{DSS} = 7\text{ mA}$
 $f = 200\text{ MHz}$ (see test circuit 1)

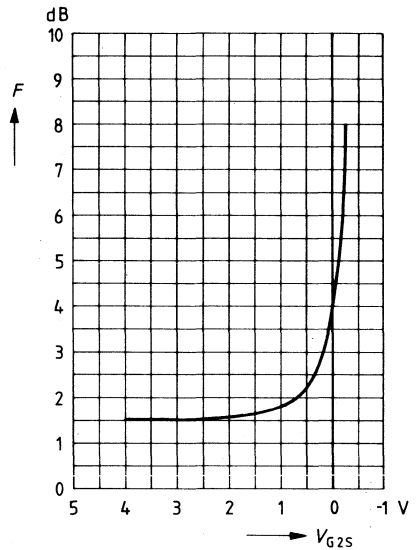

Power gain $G_{ps} = f(V_{G2S})$

$V_{DS} = 15\text{ V}$, $V_{G1S} = 0$, $I_{DSS} = 7\text{ mA}$
 $f = 800\text{ MHz}$, $R_S = 0$ (see test circuit 2)

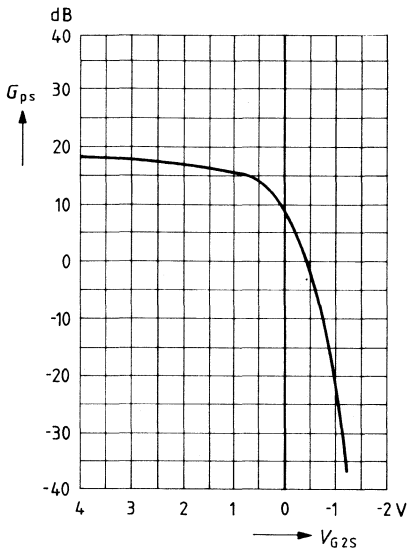

Noise figure $F = f(V_{G2S})$

$V_{DS} = 15\text{ V}$, $V_{G1S} = 0$, $I_{DSS} = 7\text{ mA}$
 $f = 800\text{ MHz}$, $R_S = 0$ (see test circuit 2)

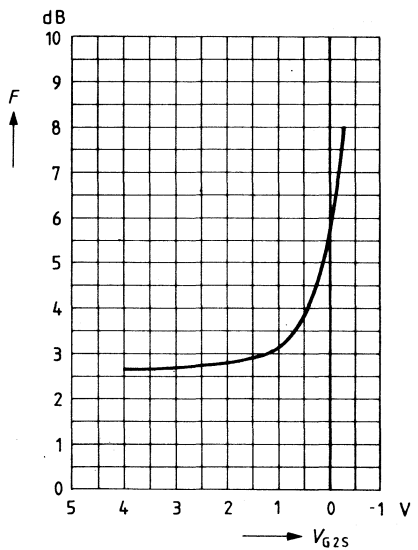

Interference voltage for 1% cross modulation

$V_{int(1\%)} = f(f_{int})^{1.1}$
 $V_{DS} = 15\text{ V}, V_{G2S} = 4\text{ V}, V_{G1S} = 1\text{ V}$
 $f = 800\text{ MHz}$ (see test circuit 2)

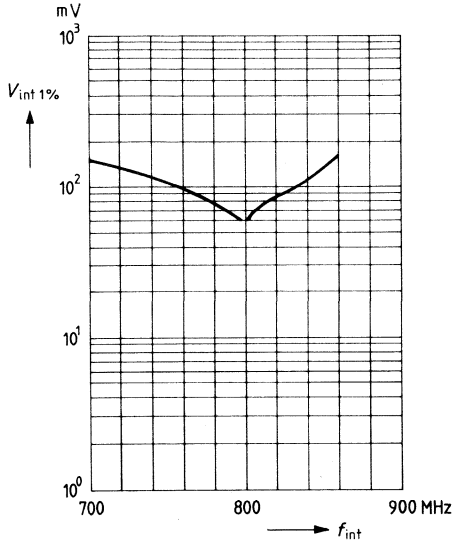

Interference voltage for 1% cross modulation

$V_{int(1\%)} = f(\Delta G_{ps})^{1.1}$
 $V_{DS} = 15\text{ V}, V_{G1S} = 1\text{ V}, f = 800\text{ MHz}$
 $f_{int} = 700\text{ MHz}$ (see test circuit 2)

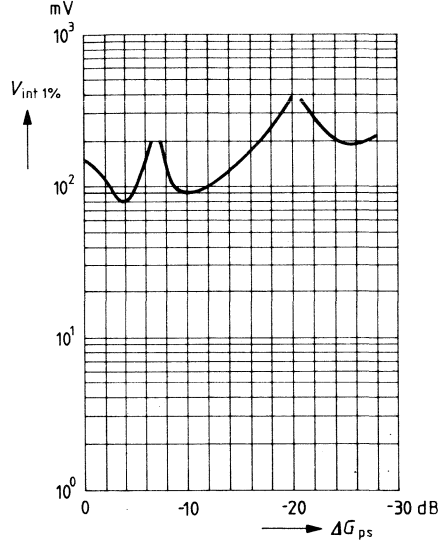

Mixer gain $G_{psc} = f(R_S)$

$f = 800\text{ MHz}, f_{osc} = 836\text{ MHz}, V_{osc} = 800\text{ mV}$
 $V_{DS} = 15\text{ V}, V_{G2S} = 4\text{ V}, I_{DSS} = 7\text{ mA}$
 (see test circuit 3)

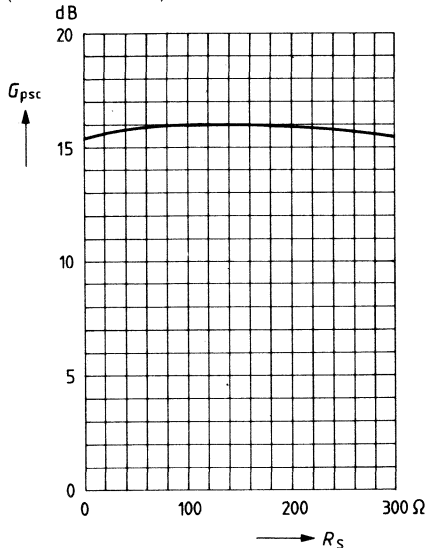

Mixer gain $G_{psc} = f(V_{osc})$

$f = 800\text{ MHz}, f_{osc} = 836\text{ MHz}, R_S = 150\ \Omega$
 $V_{DS} = 15\text{ V}, V_{G2S} = 4\text{ V}, I_{DSS} = 7\text{ mA}$
 (see test circuit 3)

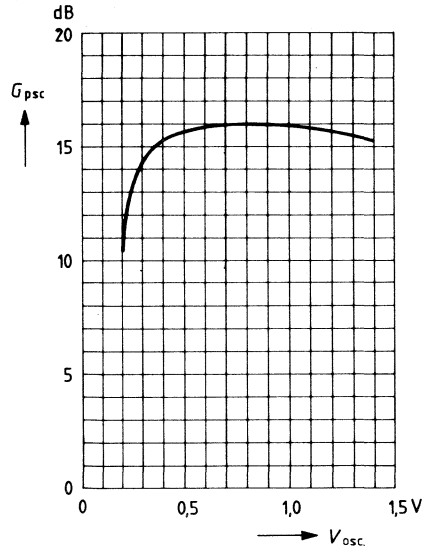

¹⁾ Footnote see page 151

Test circuit 1 for power gain and noise figure

$f = 200 \text{ MHz}$, $G_G = 2 \text{ mS}$, $G_L = 0,5 \text{ mS}$

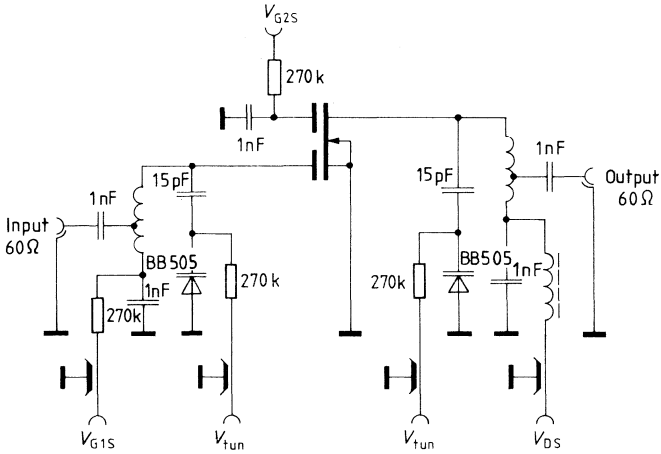

Test circuit 2 for power gain, noise figure and cross modulation

$f = 800 \text{ MHz}$, $G_G = 3,3 \text{ mS}$, $G_L = 1,0 \text{ mS}$

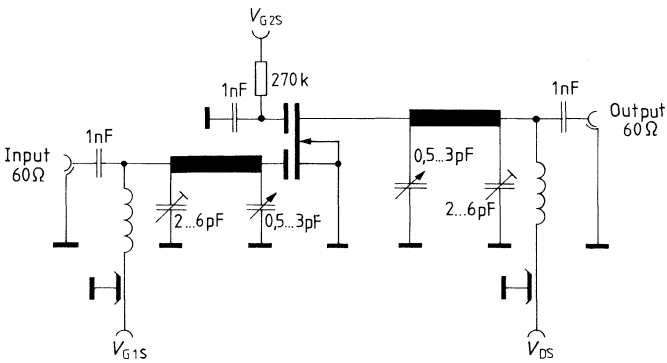

Test circuit 3 for mixer gain

$f = 800/36 \text{ MHz}$

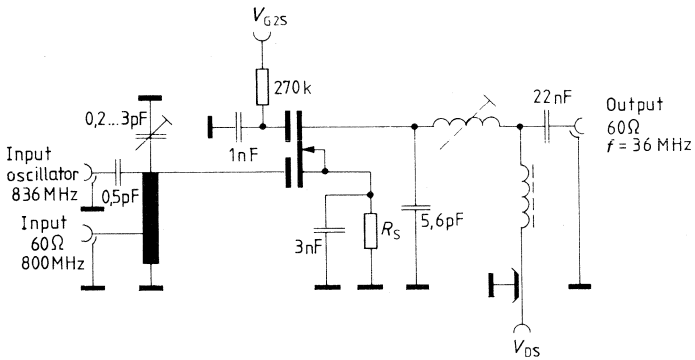

¹⁾ $V_{Int (1\%)}$ is the rms value of half the emf (terminal voltage at matching) of a 100% sine modulated TV carrier at an internal generator resistance of 60Ω , causing 1% amplitude modulation on the active carrier.

- For input and mixer stages in FM and VHF TV tuners

X-plast

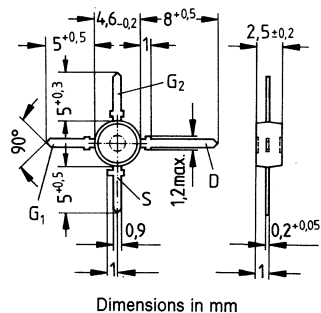

Type	BF 961
Ordering code	Q62702-F518

Maximum ratings

Drain-source voltage	V_{DS}	20	V
Drain current	I_D	30	mA
Gate 1/gate 2 peak source current	$\pm I_{G1/2SM}$	10	mA
Total power dissipation $T_A \leq 60^\circ C$	P_{tot}	200	mW
Storage temperature range	T_{stg}	-55... +150	$^\circ C$
Channel temperature	T_{ch}	150	$^\circ C$

Thermal resistance

Junction — ambient	R_{thJA}	≤ 450	K/W
--------------------	------------	------------	-----

Characteristics ($T_A = 25^\circ\text{C}$)**DC characteristics**

		min	typ	max	
Drain-source breakdown voltage $I_D = 10\ \mu\text{A}$, $-V_{G1S} = -V_{G2S} = 4\ \text{V}$	$V_{(BR)DS}$	20	—	—	V
Gate 1 source breakdown voltage $\pm I_{G1S} = 10\ \text{mA}$, $V_{G2S} = V_{DS} = 0$	$\pm V_{(BR)G1SS}$	8,5	—	17	V
Gate 2 source breakdown voltage $\pm I_{G2S} = 10\ \text{mA}$, $V_{G1S} = V_{DS} = 0$	$\pm V_{(BR)G2SS}$	8,5	—	17	V
Gate 1 source leakage current $\pm V_{G1S} = 5\ \text{V}$, $V_{G2S} = V_{DS} = 0$	$\pm I_{G1SS}$	—	—	50	nA
Gate 2 source leakage current $\pm V_{G2S} = 5\ \text{V}$, $V_{G1S} = V_{DS} = 0$	$\pm I_{G2SS}$	—	—	50	nA
Drain current $V_{DS} = 15\ \text{V}$, $V_{G1S} = 0$, $V_{G2S} = 4\ \text{V}$	I_{DSS}	4	—	20	mA
Gate 1 source pinch-off voltage $V_{DS} = 15\ \text{V}$, $V_{G2S} = 4\ \text{V}$, $I_D = 20\ \mu\text{A}$	$-V_{G1S(p)}$	—	—	3,5	V
Gate 2 source pinch-off voltage $V_{DS} = 15\ \text{V}$, $V_{G1S} = 0$, $I_D = 20\ \mu\text{A}$	$-V_{G2S(p)}$	—	—	3,5	V

Characteristics ($T_A = 25^\circ\text{C}$)

AC characteristics		min	typ	max	
Forward transconductance $V_{DS} = 15\text{ V}$, $I_D = 10\text{ mA}$, $V_{G2S} = 4\text{ V}$, $f = 1\text{ kHz}$	g_{fs}	12	17	—	mS
Gate 1 input capacitance $V_{DS} = 15\text{ V}$, $I_D = 10\text{ mA}$, $V_{G2S} = 4\text{ V}$, $f = 1\text{ MHz}$	C_{g1ss}	—	3,6	—	pF
Gate 2 input capacitance $V_{DS} = 15\text{ V}$, $I_D = 10\text{ mA}$, $V_{G2S} = 4\text{ V}$, $f = 1\text{ MHz}$	C_{g2ss}	—	1,6	—	pF
Feedback capacitance $V_{DS} = 15\text{ V}$, $I_D = 10\text{ mA}$, $V_{G2S} = 4\text{ V}$, $f = 1\text{ MHz}$	C_{dg1}	—	25	—	fF
Output capacitance $V_{DS} = 15\text{ V}$, $I_D = 10\text{ mA}$, $V_{G2S} = 4\text{ V}$, $f = 1\text{ MHz}$	C_{dss}	—	1,6	—	pF
Power gain $V_{DS} = 15\text{ V}$, $I_D = 10\text{ mA}$ $f = 200\text{ MHz}$, $G_G = 2\text{ mS}$, $G_L = 0,5\text{ mS}$ $2\Delta f = 12\text{ MHz}$ (test circuit 1)	G_{ps}	—	23	—	dB
Noise figure $V_{DS} = 15\text{ V}$, $I_D = 10\text{ mA}$ $f = 200\text{ MHz}$, $G_G = 2\text{ mS}$, $G_L = 0,5\text{ mS}$ (test circuit 1)	F	—	1,1	—	dB
Gain control range $V_{DS} = 15\text{ V}$, $V_{G2S} = 4 \dots -2\text{ V}$, $f = 200\text{ MHz}$ (test circuit 1)	ΔG_{ps}	—	50	—	dB
Mixer gain (additive) $V_{DS} = 15\text{ V}$, $V_{G2S} = 6\text{ V}$, $R_S = 220\ \Omega$ $f = 200\text{ MHz}$, $f_{IF} = 36\text{ MHz}$ $2\Delta f_{IF} = 5\text{ MHz}$, $V_{osc} = 0,5\text{ V}$ (test circuit 2)	G_{psc}	—	16	—	dB
Mixer gain (multiplicative) $V_{DS} = 15\text{ V}$, $V_{G1S} = 1,7\text{ V}$, $V_{G2S} = 2,5\text{ V}$ $R_S = 220\ \Omega$, $f = 200\text{ MHz}$, $f_{IF} = 36\text{ MHz}$ $2\Delta f_{IF} = 5\text{ MHz}$, $V_{osc} = 2\text{ V}$ (test circuit 3)	G_{psc}	—	18	—	dB

Total power dissipation $P_{tot} = f(T_A)$

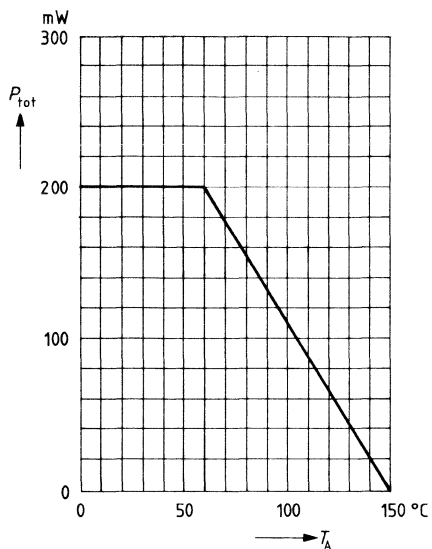

Output characteristics $I_D = f(V_{DS})$

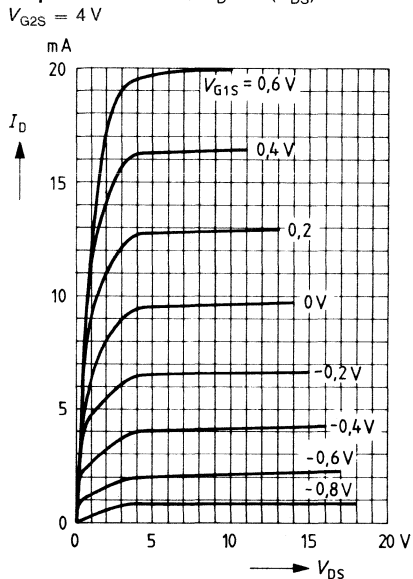

Gate 1 forward transconductance

$g_{fs1} = f(V_{G1S})$
 $V_{DS} = 15\text{ V}$
 $I_{DSS} = 10\text{ mA}, f = 1\text{ kHz}$

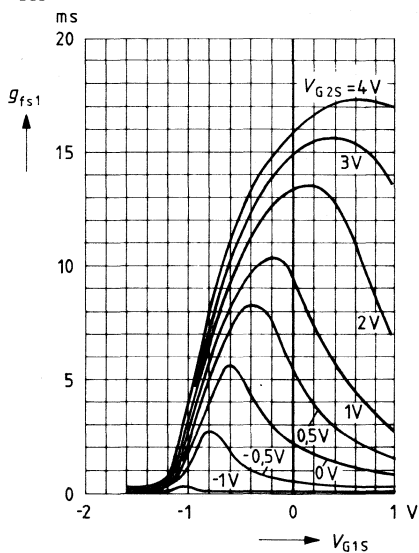

Gate 1 forward transconductance

$g_{fs1} = f(V_{G2S})$
 $V_{DS} = 15\text{ V}$
 $I_{DSS} = 10\text{ mA}, f = 1\text{ kHz}$

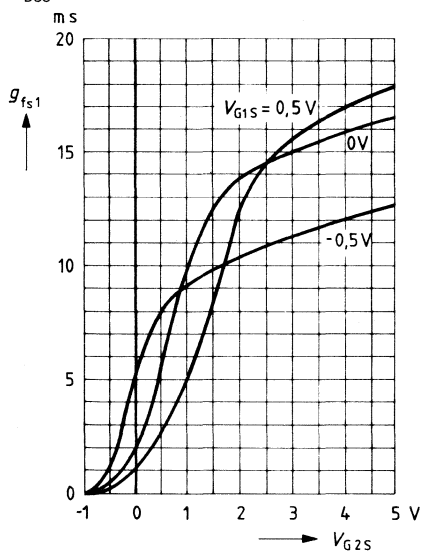

Drain current $I_D = f(V_{G1S})$
 $V_{DS} = 15\text{ V}$

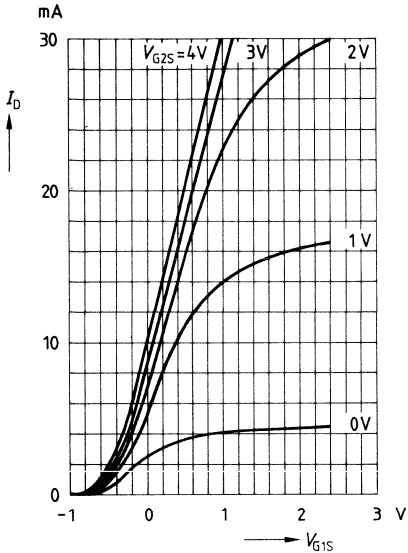

Gate 1 input capacitance $c_{g1ss} = f(V_{G1S})$
 $V_{G2S} = 4\text{ V}, V_{DS} = 15\text{ V}$
 $I_{DSS} = 10\text{ mA}, f = 1\text{ MHz}$

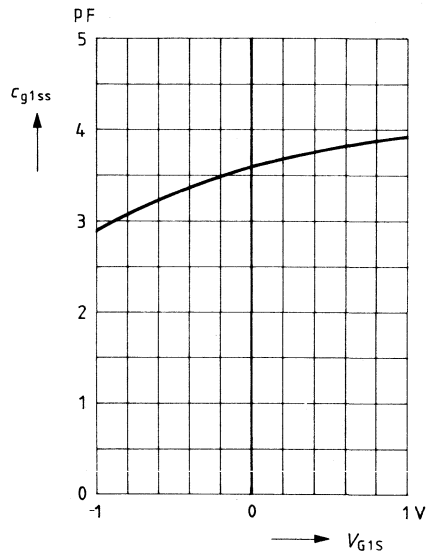

Gate 2 input capacitance $c_{g2ss} = f(V_{G2S})$
 $V_{G1S} = 0\text{ V}, V_{DS} = 15\text{ V}$
 $I_{DSS} = 10\text{ mA}, f = 1\text{ MHz}$

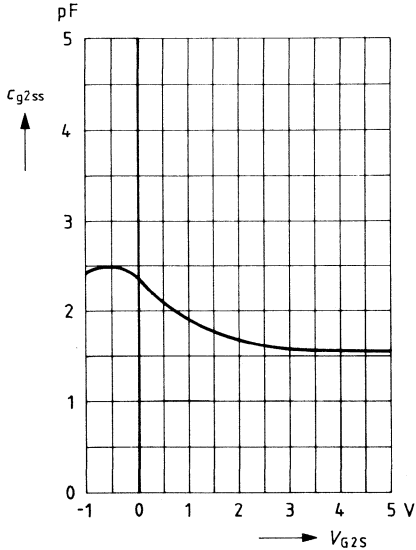

Output capacitance $c_{dss} = f(V_{DS})$
 $V_{G1S} = 0\text{ V}, V_{G2S} = 4\text{ V}$
 $I_{DSS} = 10\text{ mA}, f = 1\text{ MHz}$

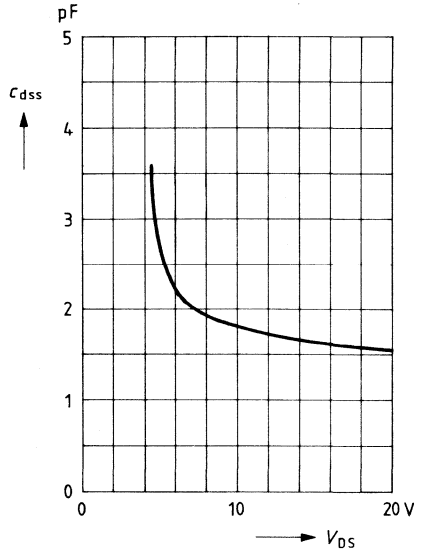

Gate 1 input admittance y_{11s}

$V_{DS} = 15\text{ V}, V_{G2S} = 4\text{ V}$

(common source)

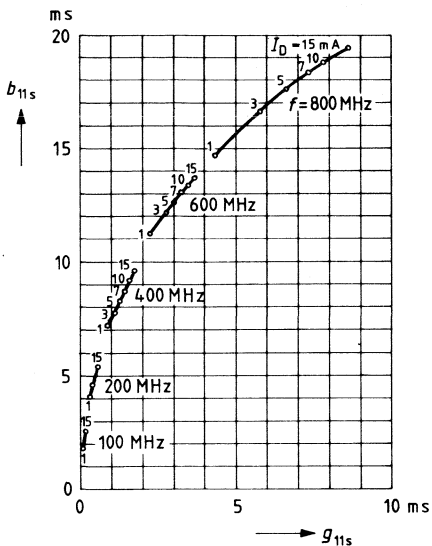

Gate 1 forward transfer admittance y_{21s}

$V_{DS} = 15\text{ V}, V_{G2S} = 4\text{ V}$

(common source)

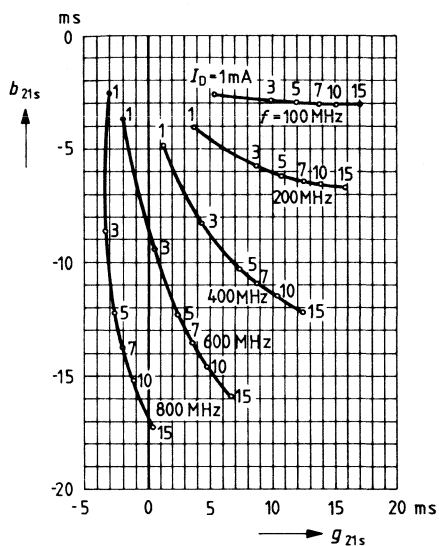

Output admittance y_{22s}

$V_{DS} = 15\text{ V}, V_{G2S} = 4\text{ V}$

(common source)

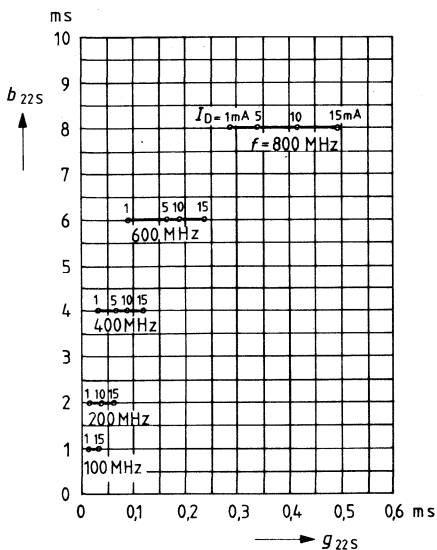

Power gain $G_{ps} = f(V_{G2S})$

$V_{DS} = 15\text{ V}$, $V_{G1S} = 0\text{ V}$, $I_{DSS} = 10\text{ mA}$
 $f = 200\text{ MHz}$ (see test circuit 1)

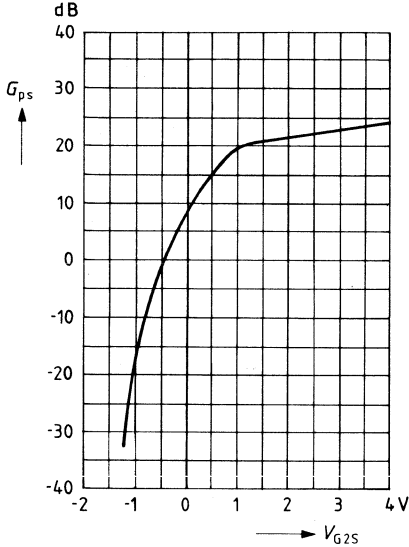

Noise figure $F = f(V_{G2S})$

$V_{DS} = 15\text{ V}$, $V_{G1S} = 0\text{ V}$, $I_{DSS} = 10\text{ mA}$
 $f = 200\text{ MHz}$, (see test circuit 1)

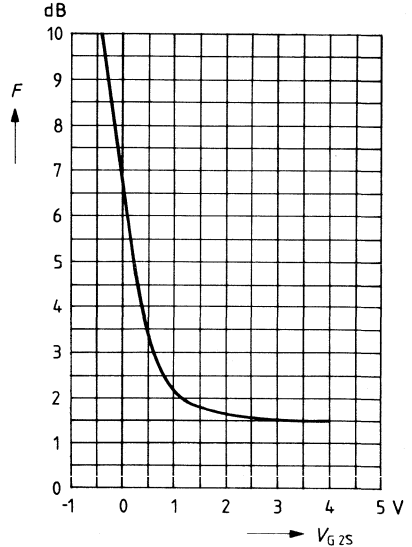

Interference voltage for 1% cross modulation

$V_{int}(1\%) = f(\Delta G_{psc})^{11}$
 $V_{DS} = 15\text{ V}$, $V_{G1S} = 0$, $f = 200\text{ MHz}$
 $f_{int} = 221\text{ MHz}$ (see test circuit 1)

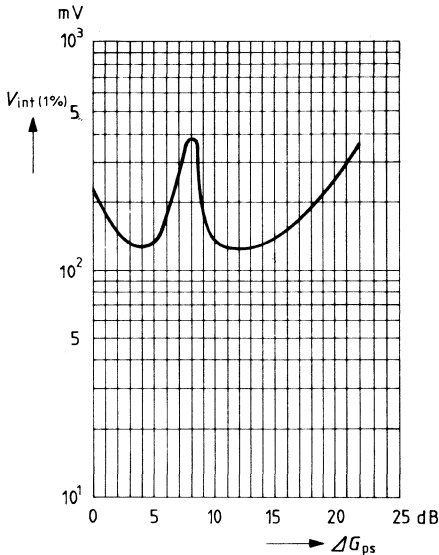

Interference voltage for 1% cross modulation

$V_{int}(1\%) = f(f_{int})^{11}$
 $V_{DS} = 15\text{ V}$, $V_{G2S} = 4\text{ V}$, $V_{G1S} = 0$
 $f = 200\text{ MHz}$ (see test circuit 1)

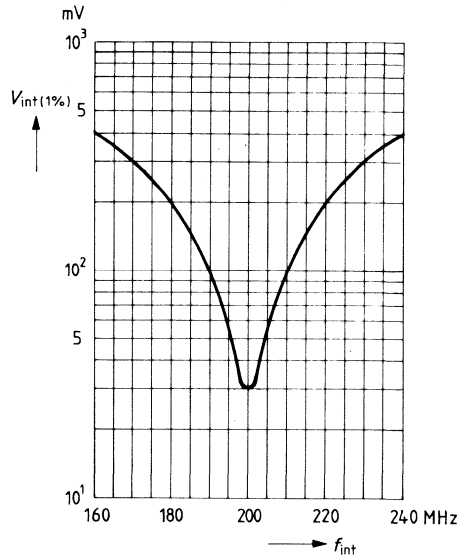

1) Footnote see page 161

Mixer gain (additive) $G_{psc} = f(V_{osc})$

$V_D = 15\text{ V}$, $V_{G1S} = 0$, $V_{G2S} = 6\text{ V}$
 $R_S = 220\ \Omega$, $I_{DSS} = 10\text{ mA}$, $f = 200\text{ MHz}$
 $f_{IF} = 36\text{ MHz}$ (see test circuit 2)

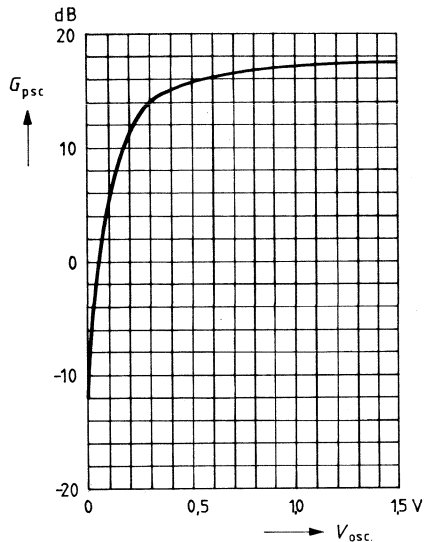

Mixer gain (additive) $G_{psc} = f(V_{G2S})$

$V_D = 15\text{ V}$, $V_{G1S} = 0$, $R_S = 220\ \Omega$
 $V_{osc} = 0,5\text{ V}$, $I_{DSS} = 10\text{ mA}$, $f = 200\text{ MHz}$
 $f_{IF} = 36\text{ MHz}$ (see test circuit 2)

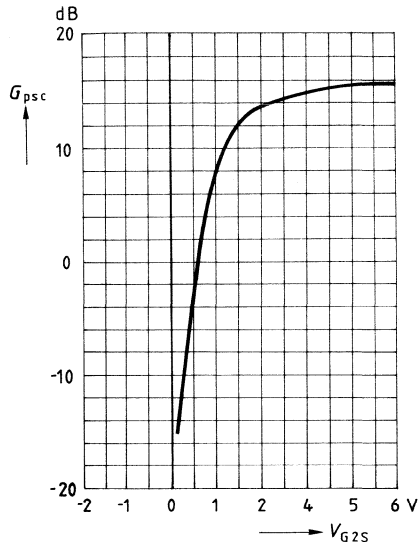

Mixer gain (additive) $G_{psc} = f(R_S)$

$V_D = 15\text{ V}$, $V_{G1S} = 0$, $V_{G2S} = 6\text{ V}$
 $V_{osc} = 0,5\text{ V}$, $f = 200\text{ MHz}$
 $f_{IF} = 36\text{ MHz}$ (see test circuit 2)

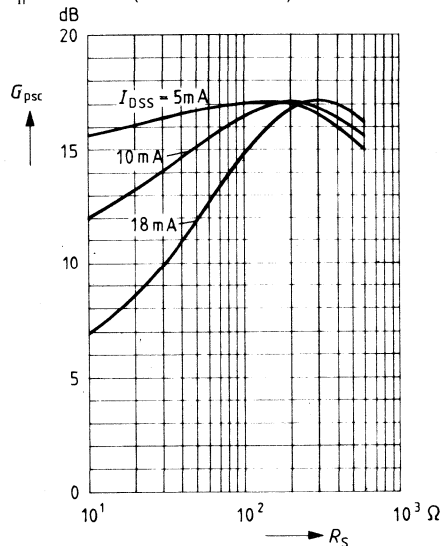

Mixer gain (multiplicative) $G_{psc} = f(V_{G2S})$

$V_D = 15\text{ V}$, $V_{G1S} = 1,7\text{ V}$, $R_S = 200\ \Omega$
 $I_{DSS} = 10\text{ mA}$, $f = 200\text{ MHz}$
 $f_{IF} = 36\text{ MHz}$ (see test circuit 3)

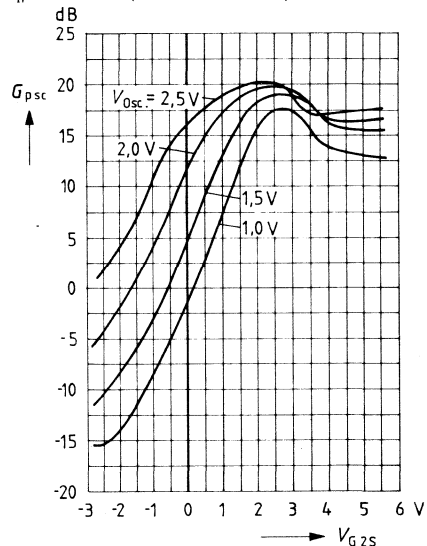

Test circuit 1 for power gain, noise figure and cross modulation

$f = 200 \text{ MHz}$, $G_G = 2 \text{ mS}$, $G_L = 0,5 \text{ mS}$

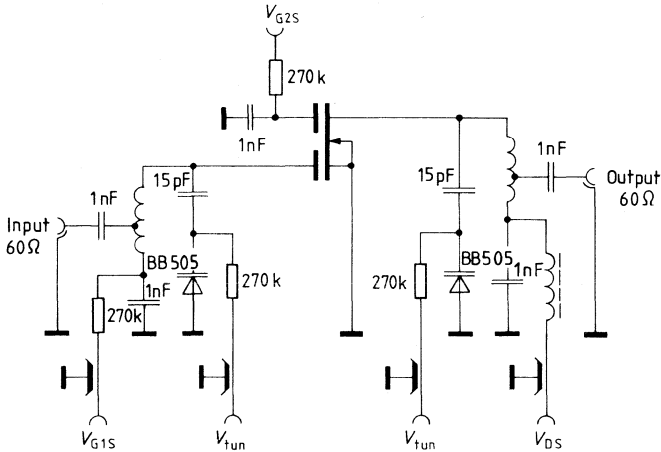

Test circuit 2 for mixer gain (additive)

$f = 200 \text{ MHz}$, $f_{osc} = 236 \text{ MHz}$, $2 \Delta f_{IF} = 5 \text{ MHz}$

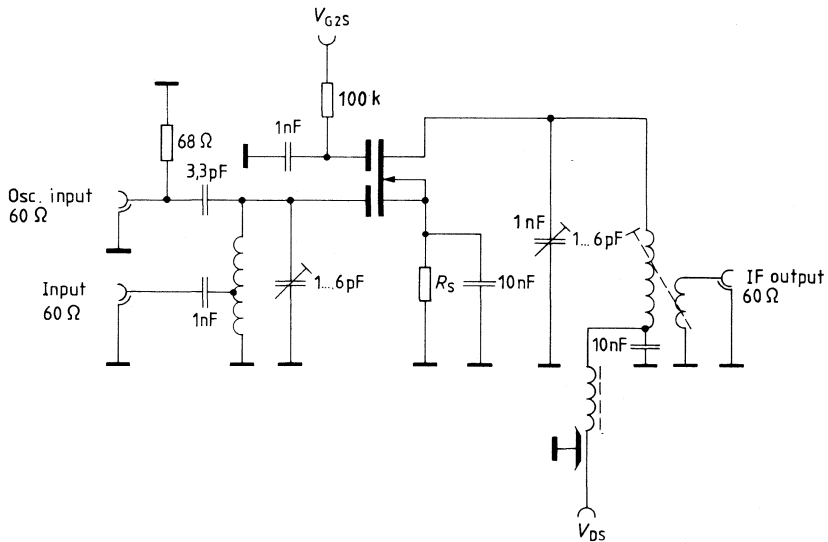

Characteristics ($T_A = 25^\circ\text{C}$)

DC characteristics		min	typ	max	
Drain-source breakdown voltage $I_D = 10\ \mu\text{A}$, $-V_{G1S} = -V_{G2S} = 4\ \text{V}$	$V_{(BR)DS}$	20	—	—	V
Gate 1 source breakdown voltage $\pm I_{G1S} = 10\ \text{mA}$, $V_{G2S} = V_{DS} = 0$	$\pm V_{(BR)G1SS}$	8,5	—	17	V
Gate 2 source breakdown voltage $\pm I_{G2S} = 10\ \text{mA}$, $V_{G1S} = V_{DS} = 0$	$\pm V_{(BR)G2SS}$	8,5	—	17	V
Gate 1 source leakage current $\pm V_{G1S} = 5\ \text{V}$, $V_{G2S} = V_{DS} = 0$	$\pm I_{G1SS}$	—	—	50	nA
Gate 2 source leakage current $\pm V_{G2S} = 5\ \text{V}$, $V_{G1S} = V_{DS} = 0$	$\pm I_{G2SS}$	—	—	50	nA
Drain current $V_{DS} = 15\ \text{V}$, $V_{G1S} = 0$, $V_{G2S} = 4\ \text{V}$	I_{DSS}	6	—	40	mA
Gate 1 source pinch-off voltage $V_{DS} = 15\ \text{V}$, $V_{G2S} = 4\ \text{V}$, $I_D = 20\ \mu\text{A}$	$-V_{G1S(p)}$	—	—	3,5	V
Gate 2 source pinch-off voltage $V_{DS} = 15\ \text{V}$, $V_{G1S} = 0$, $I_D = 20\ \mu\text{A}$	$-V_{G2S(p)}$	—	—	3,0	V
AC characteristics					
Forward transconductance $V_{DS} = 15\ \text{V}$, $I_D = 10\ \text{mA}$, $V_{G2S} = 4\ \text{V}$, $f = 1\ \text{kHz}$	g_{fs}	16	25	—	mS
Gate 1 input capacitance $V_{DS} = 15\ \text{V}$, $I_D = 10\ \text{mA}$, $V_{G2S} = 4\ \text{V}$, $f = 1\ \text{MHz}$	C_{g1ss}	—	6	—	pF
Gate 2 input capacitance $V_{DS} = 15\ \text{V}$, $I_D = 10\ \text{mA}$, $V_{G2S} = 4\ \text{V}$, $f = 1\ \text{MHz}$	C_{g2ss}	—	2,5	—	pF
Feedback capacitance $V_{DS} = 15\ \text{V}$, $I_D = 10\ \text{mA}$, $V_{G2S} = 4\ \text{V}$, $f = 1\ \text{MHz}$	C_{dg1}	—	50	—	fF
Output capacitance $V_{DS} = 15\ \text{V}$, $I_D = 10\ \text{mA}$, $V_{G2S} = 4\ \text{V}$, $f = 1\ \text{MHz}$	C_{dss}	—	2,5	—	pF
Power gain $V_{DS} = 15\ \text{V}$, $I_D = 10\ \text{mA}$, $f = 200\ \text{MHz}$, $G_G = 2,5\ \text{mS}$, $G_L = 0,8\ \text{mS}$ $2\Delta f = 12\ \text{MHz}$ (test circuit)	G_{ps}	—	25	—	dB
Noise figure $V_{DS} = 15\ \text{V}$, $I_D = 10\ \text{mA}$ $f = 200\ \text{MHz}$, $G_G = 2,5\ \text{mS}$, $G_L = 0,8\ \text{mS}$ (test circuit)	F	—	1,5	—	dB

Total power dissipation $P_{tot} = f(T_A)$

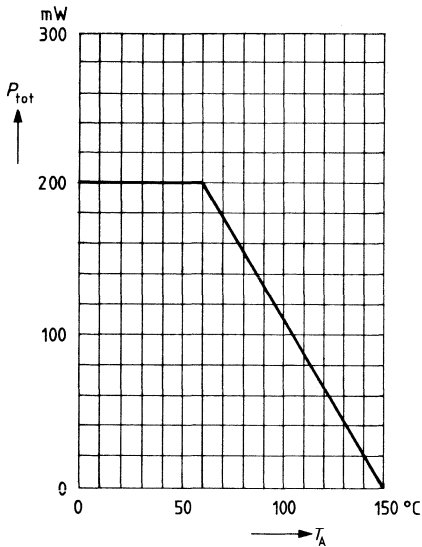

Output characteristics $I_D = f(V_{DS})$

$V_{G2S} = 4 V$

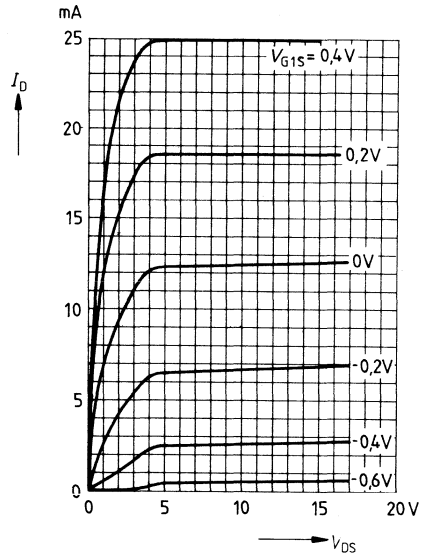

Gate 1 forward transconductance

$g_{fs1} = f(V_{G1S})$

$V_{DS} = 15 V$

$I_{DSS} = 10 mA, f = 1 kHz$

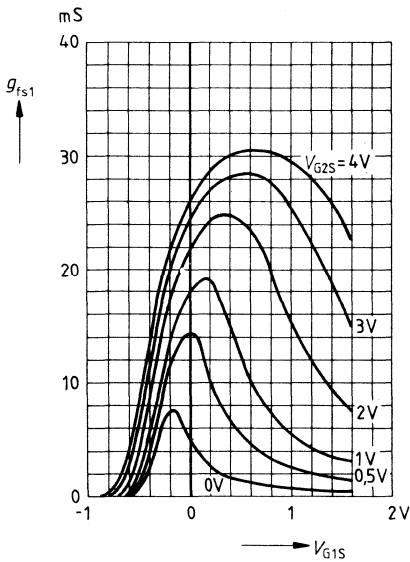

Gate 1 forward transconductance

$g_{fs1} = f(V_{G2S})$

$V_{DS} = 15 V$

$I_{DSS} = 10 mA, f = 1 kHz$

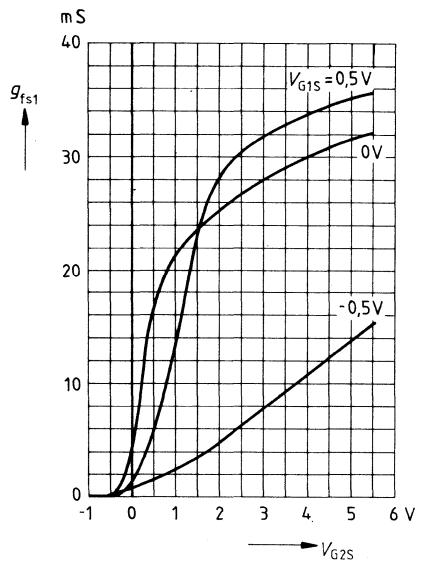

Drain current $I_D = f(V_{G1S})$

$V_{DS} = 15 \text{ V}$

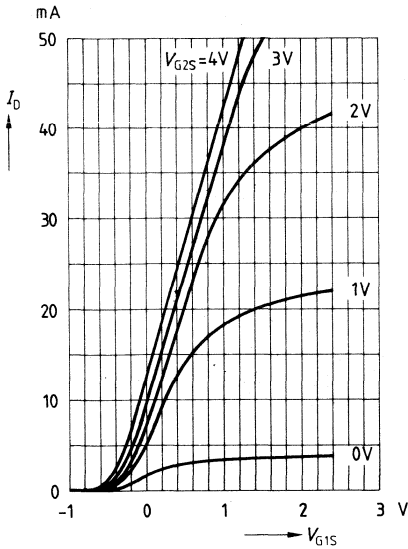

Gate 1 input capacitance $c_{g1ss} = f(V_{G1S})$

$V_{G2S} = 4 \text{ V}, V_{DS} = 15 \text{ V}$

$I_{DSS} = 10 \text{ mA}, f = 1 \text{ MHz}$

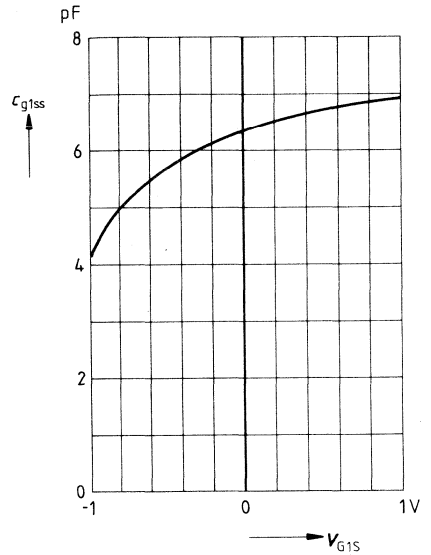

Gate 2 input capacitance $c_{g2ss} = f(V_{G2S})$

$V_{G1S} = 0 \text{ V}, V_{DS} = 15 \text{ V}$

$I_{DSS} = 10 \text{ mA}, f = 1 \text{ MHz}$

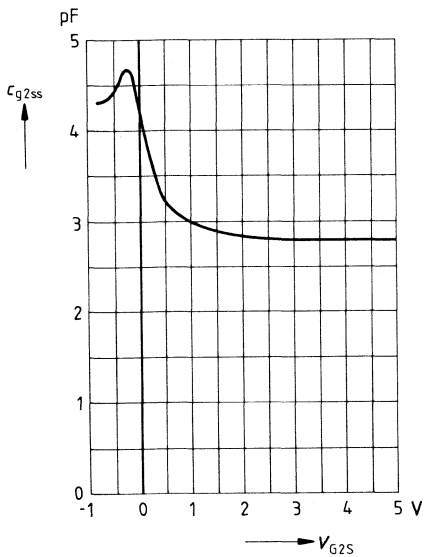

Output capacitance $c_{dss} = f(V_{DS})$

$V_{G1S} = 0 \text{ V}, V_{G2S} = 4 \text{ V}$

$I_{DSS} = 10 \text{ mA}, f = 1 \text{ MHz}$

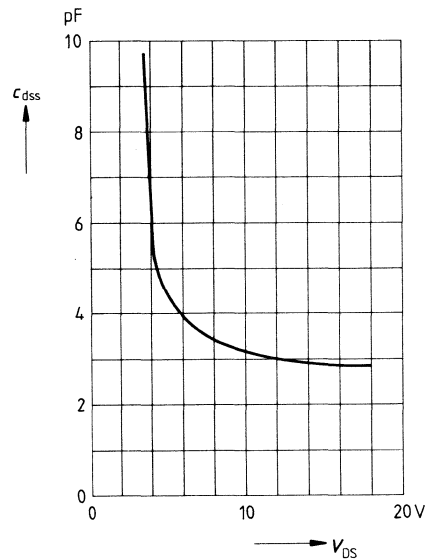

Gate 1 input admittance y_{11s}

$V_{DS} = 15 \text{ V}$, $V_{G2S} = 4 \text{ V}$

(common source)

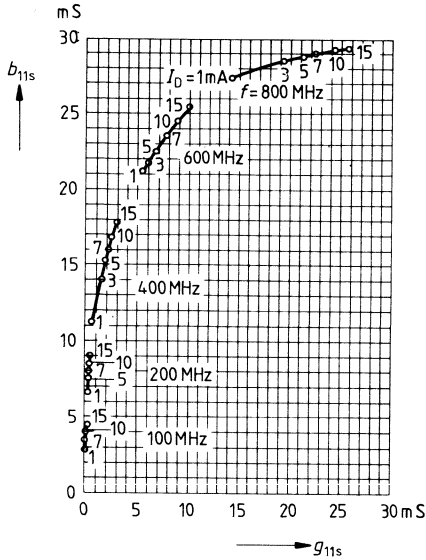

Gate 1 forward transfer admittance y_{21s}

$V_{DS} = 15 \text{ V}$, $V_{G2S} = 4 \text{ V}$

(common source)

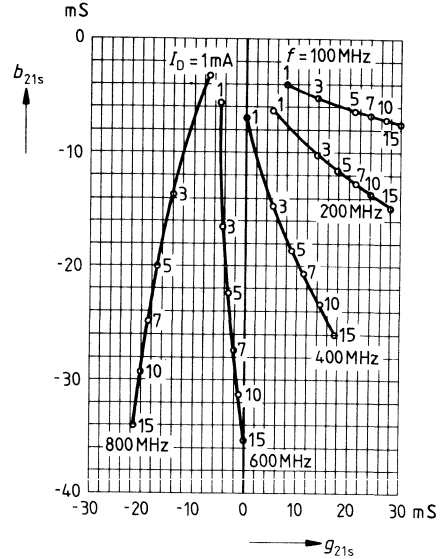

Output admittance y_{22s}

$V_{DS} = 15 \text{ V}$, $V_{G2S} = 4 \text{ V}$

(common source)

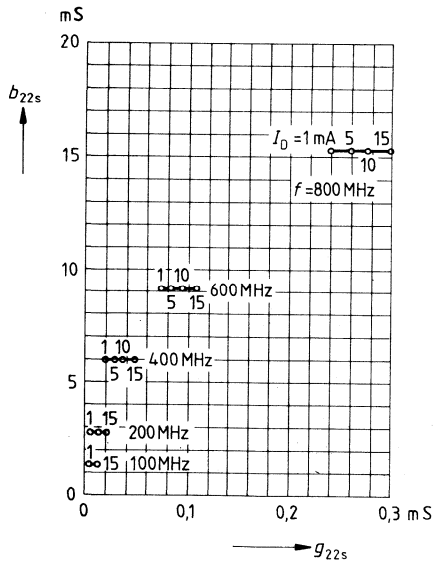

Power gain $G_{ps} = f(V_{G2S})$

$V_{DS} = 15\text{ V}, V_{G1S} = 0\text{ V}$

$I_{DSS} = 10\text{ mA}, f = 200\text{ MHz}$

(see test circuit)

Noise figure $F = f(V_{G2S})$

$V_{DS} = 15\text{ V}, V_{G1S} = 0\text{ V}$

$I_{DSS} = 10\text{ mA}, f = 200\text{ MHz}$

(see test circuit)

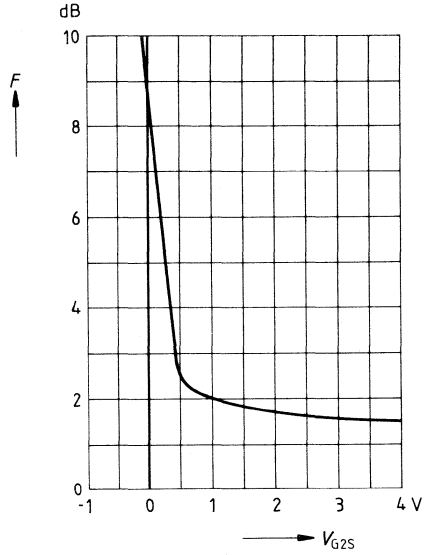
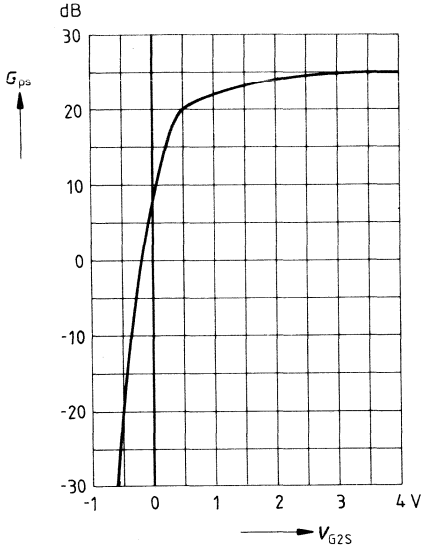

Test circuit for power gain and noise figure

$f = 200\text{ MHz}, G_G = 2\text{ mS}, G_L = 0,5\text{ mS}$

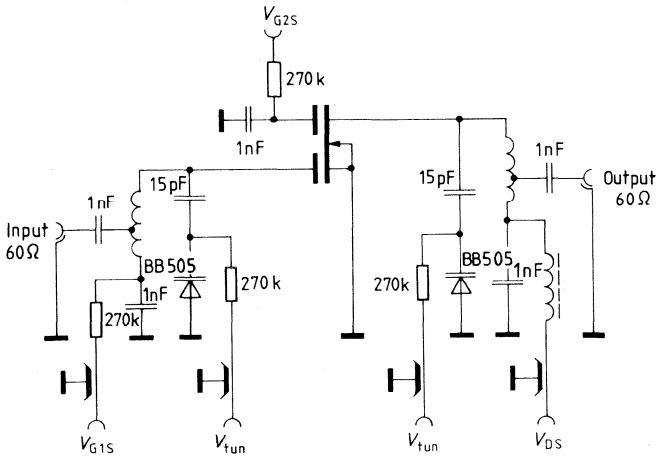

- For VHF applications, especially for input and mixer stages with a wide tuning range, e. g. in CATV tuners

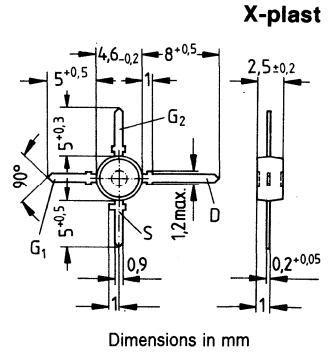

Type	BF 964 S
Ordering code	Q62702-F446

Maximum ratings

Drain-source voltage	V_{DS}	20	V
Drain current	I_D	30	mA
Gate 1/gate 2 peak source current	$\pm I_{G1/2SM}$	10	mA
Total power dissipation $T_A \leq 60^\circ C$	P_{tot}	200	mW
Storage temperature range	T_{stg}	-55... +150	$^\circ C$
Channel temperature	T_{Ch}	150	$^\circ C$

Thermal resistance

Junction — ambient	R_{thJA}	≤ 450	K/W
--------------------	------------	------------	-----

Characteristics ($T_A = 25\text{ }^\circ\text{C}$)

DC characteristics

		min	typ	max	
Drain-source breakdown voltage $I_D = 10\text{ }\mu\text{A}$, $-V_{G1S} = -V_{G2S} = 4\text{ V}$	$V_{(BR)DS}$	20	—	—	V
Gate 1 source breakdown voltage $\pm I_{G1S} = 10\text{ mA}$, $V_{G2S} = V_{DS} = 0$	$\pm V_{(BR)G1SS}$	8,5	—	17	V
Gate 2 source breakdown voltage $\pm I_{G2S} = 10\text{ mA}$, $V_{G1S} = V_{DS} = 0$	$\pm V_{(BR)G2SS}$	8,5	—	17	V
Gate 1 source leakage current $\pm V_{G1S} = 5\text{ V}$, $V_{G2S} = V_{DS} = 0$	$\pm I_{G1SS}$	—	—	50	nA
Gate 2 source leakage current $\pm V_{G2S} = 5\text{ V}$, $V_{G1S} = V_{DS} = 0$	$\pm I_{G2SS}$	—	—	50	nA
Drain current $V_{DS} = 15\text{ V}$, $V_{G1S} = 0$, $V_{G2S} = 4\text{ V}$	I_{DSS}	2	—	20	mA
Gate 1 source pinch-off voltage $V_{DS} = 15\text{ V}$, $V_{G2S} = 4\text{ V}$, $I_D = 20\text{ }\mu\text{A}$	$-V_{G1S(p)}$	—	—	2,5	V
Gate 2 source pinch-off voltage $V_{DS} = 15\text{ V}$, $V_{G1S} = 0$, $I_D = 20\text{ }\mu\text{A}$	$-V_{G2S(p)}$	—	—	2,0	V

AC characteristics

Forward transconductance $V_{DS} = 15\text{ V}$, $I_D = 10\text{ mA}$, $V_{G2S} = 4\text{ V}$, $f = 1\text{ kHz}$	g_{fs}	15	18	—	mS
Gate 1 input capacitance $V_{DS} = 15\text{ V}$, $I_D = 10\text{ mA}$, $V_{G2S} = 4\text{ V}$, $f = 1\text{ MHz}$	C_{g1ss}	—	2,5	—	pF
Gate 2 input capacitance $V_{DS} = 15\text{ V}$, $I_D = 10\text{ mA}$, $V_{G2S} = 4\text{ V}$, $f = 1\text{ MHz}$	C_{g2ss}	—	1,2	—	pF
Feedback capacitance $V_{DS} = 15\text{ V}$, $I_D = 10\text{ mA}$, $V_{G2S} = 4\text{ V}$, $f = 1\text{ MHz}$	C_{dg1}	—	25	—	fF
Output capacitance $V_{DS} = 15\text{ V}$, $I_D = 10\text{ mA}$, $V_{G2S} = 4\text{ V}$, $f = 1\text{ MHz}$	C_{dss}	—	1	—	pF
Power gain $V_{DS} = 15\text{ V}$, $I_D = 10\text{ mA}$, $f = 200\text{ MHz}$, $G_G = 2\text{ mS}$, $G_L = 0,5\text{ mS}$ (test circuit)	G_{ps}	—	25	—	dB
Noise figure $V_{DS} = 15\text{ V}$, $I_D = 10\text{ mA}$, $f = 200\text{ MHz}$, $G_G = 2\text{ mS}$, $G_L = 0,5\text{ mS}$ (test circuit)	F	—	1	—	dB
Gain control range $V_{DS} = 15\text{ V}$, $V_{G2S} = 4...-2\text{ V}$, $f = 200\text{ MHz}$ (test circuit)	ΔG_{ps}	50	—	—	dB

Total power dissipation $P_{tot} = f(T_A)$

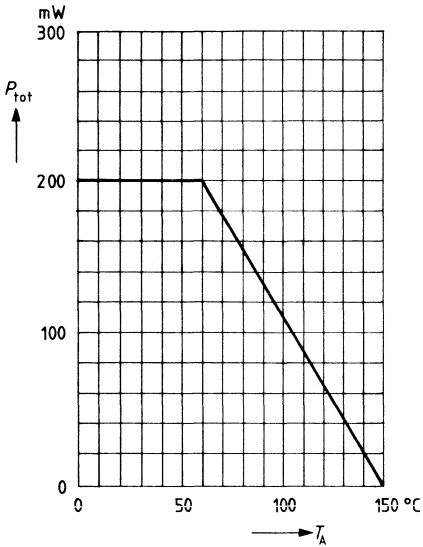

Output characteristics $I_D = f(V_{DS})$

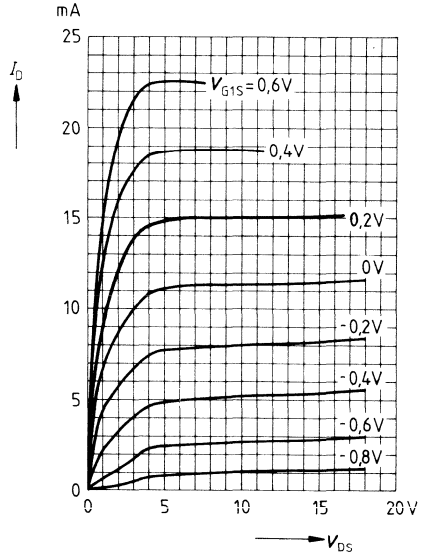

Gate 1 forward transconductance

$g_{fs1} = f(V_{G1S})$
 $V_{DS} = 15\text{ V}$
 $I_{DSS} = 10\text{ mA}, f = 1\text{ kHz}$

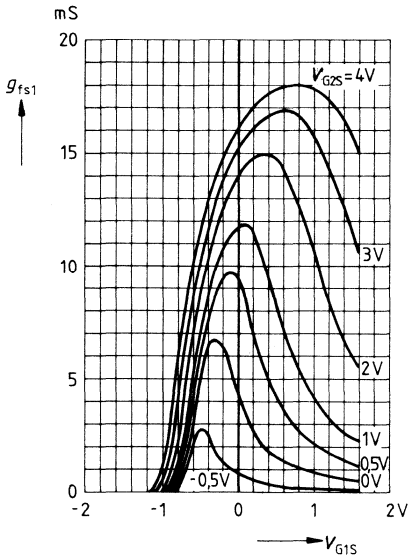

Gate 1 forward transconductance

$g_{fs1} = f(V_{G2S})$
 $V_{DS} = 15\text{ V}$
 $I_{DSS} = 10\text{ mA}, f = 1\text{ kHz}$

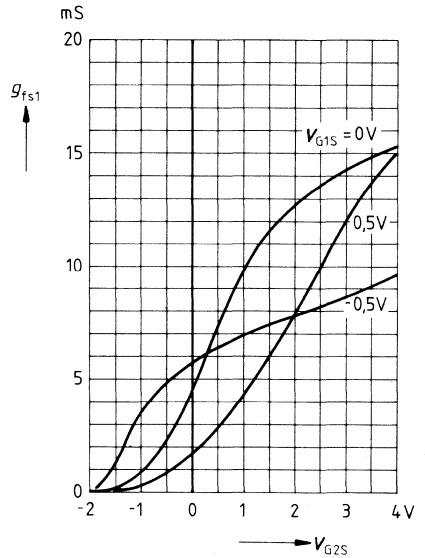

Drain current $I_D = f(V_{G1S})$

$V_{DS} = 15\text{ V}$

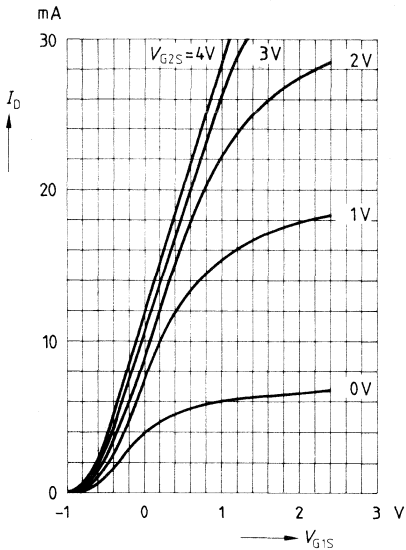

Gate 1 input capacitance $c_{g1ss} = f(V_{G1S})$

$V_{G2S} = 4\text{ V}, V_{DS} = 15\text{ V}$

$I_{DSS} = 10\text{ mA}, f = 1\text{ MHz}$

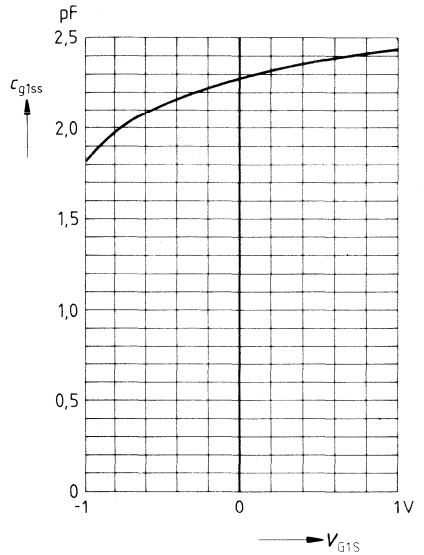

Gate 2 input capacitance $c_{g2ss} = f(V_{G2S})$

$V_{G1S} = 0\text{ V}, V_{DS} = 15\text{ V}$

$I_{DSS} = 10\text{ mA}, f = 1\text{ MHz}$

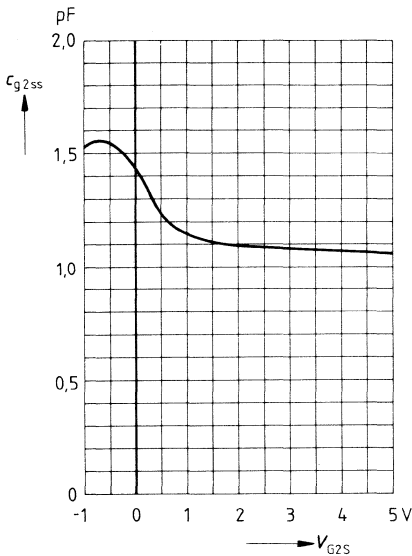

Output capacitance $c_{dss} = f(V_{DS})$

$V_{G1S} = 0\text{ V}, V_{G2S} = 4\text{ V}$

$I_{DSS} = 10\text{ mA}, f = 1\text{ MHz}$

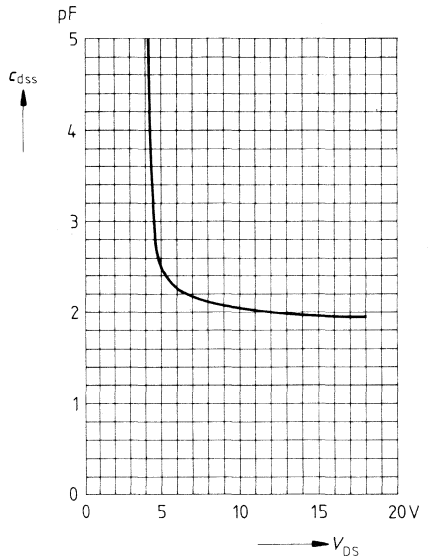

Gate 1 input admittance y_{11s}

$V_{DS} = 15\text{ V}$, $V_{GS2} = 4\text{ V}$
(common source)

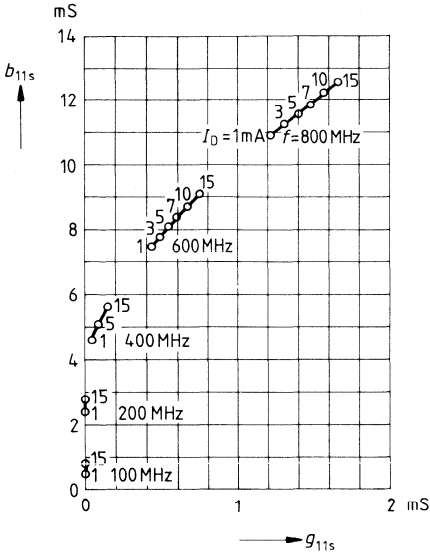

Gate 1 forward transfer admittance y_{21s}

$V_{DS} = 15\text{ V}$, $V_{GS2} = 4\text{ V}$
(common source)

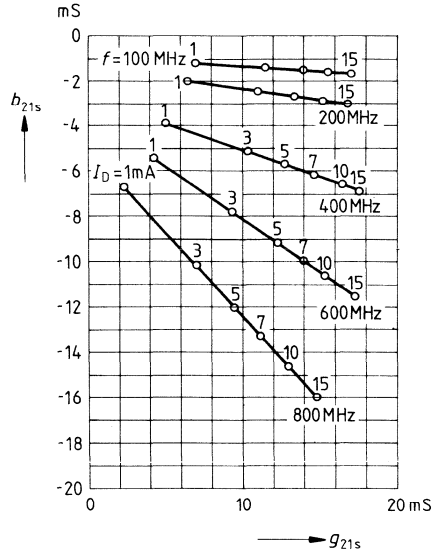

Output admittance y_{22s}

$V_{DS} = 15\text{ V}$, $V_{GS2} = 4\text{ V}$
(common source)

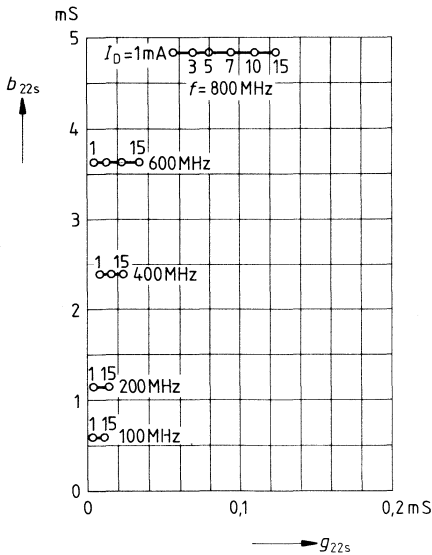

Power gain $G_{ps} = f(V_{G2S})$

$V_{DS} = 15\text{ V}, V_{G1S} = 0\text{ V}$

$I_{DSS} = 10\text{ mA}, f = 200\text{ MHz}$

(see test circuit)

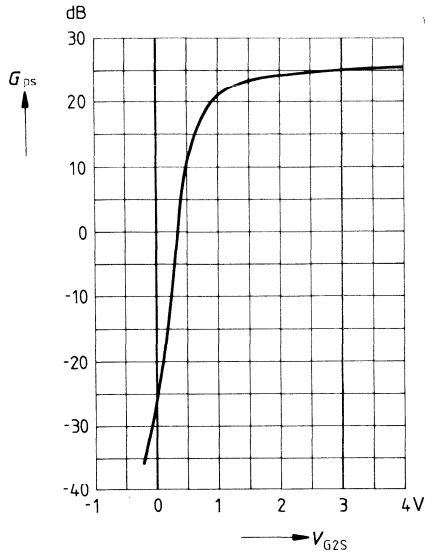

Noise figure $F = f(V_{G2S})$

$V_{DS} = 15\text{ V}, V_{G1S} = 0\text{ V}$

$I_{DSS} = 10\text{ mA}, f = 200\text{ MHz}$

(see test circuit)

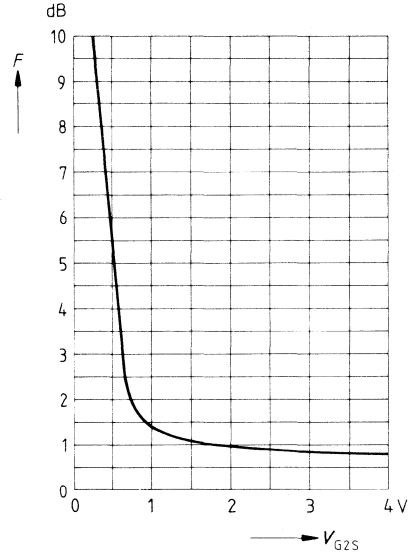

Test circuit for power gain and noise figure

$f = 200\text{ MHz}, G_G = 2\text{ mS}, G_L = 0,5\text{ mS}$

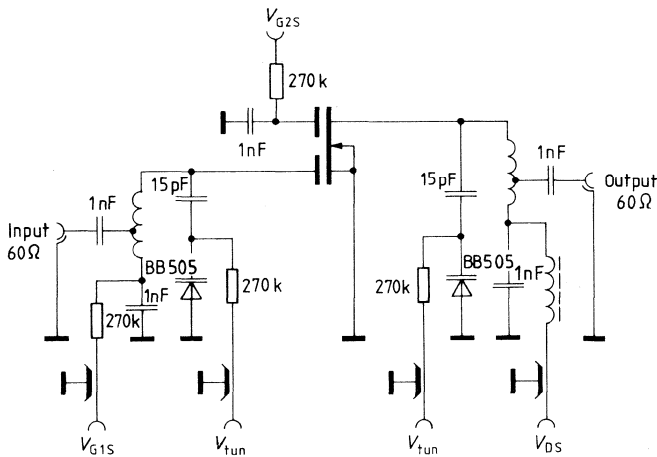

- Integrated suppression network against spurious VHF oscillations
- For VHF applications, especially in TV tuners with extended VHF band, e. g. CATV tuners

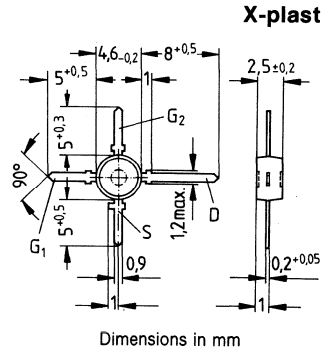

Type	BF 965
Ordering code	Q62702-F660

Maximum ratings

Drain-source voltage	V_{DS}	20	V
Drain current	I_D	30	mA
Gate 1/gate 2 peak source current	$\pm I_{G1/2SM}$	10	mA
Total power dissipation	P_{tot}	200	mW
$T_A \leq 60^\circ C$			
Storage temperature range	T_{stg}	-55... +150	$^\circ C$
Channel temperature	T_{Ch}	150	$^\circ C$

Thermal resistance

Junction — ambient	R_{thJA}	≤ 450	K/W
--------------------	------------	------------	-----

Characteristics ($T_A = 25^\circ\text{C}$)

DC characteristics

		min	typ	max	
Drain-source breakdown voltage $I_D = 10\ \mu\text{A}$, $-V_{G1S} = -V_{G2S} = 4\ \text{V}$	$V_{(BR)DS}$	20	—	—	V
Gate 1 source breakdown voltage $\pm I_{G1S} = 10\ \text{mA}$, $V_{G2S} = V_{DS} = 0$	$\pm V_{(BR)G1SS}$	8,5	—	17	V
Gate 2 source breakdown voltage $\pm I_{G2S} = 10\ \text{mA}$, $V_{G1S} = V_{DS} = 0$	$\pm V_{(BR)G2SS}$	8,5	—	17	V
Gate 1 source leakage current $\pm V_{G1S} = 5\ \text{V}$, $V_{G2S} = V_{DS} = 0$	$\pm I_{G1SS}$	—	—	50	nA
Gate 2 source leakage current $\pm V_{G2S} = 5\ \text{V}$, $V_{G1S} = V_{DS} = 0$	$\pm I_{G2SS}$	—	—	50	nA
Drain current $V_{DS} = 15\ \text{V}$, $V_{G1S} = 0$, $V_{G2S} = 4\ \text{V}$	I_{DSS}	2	—	20	mA
Gate 1 source pinch-off voltage $V_{DS} = 15\ \text{V}$, $V_{G2S} = 4\ \text{V}$, $I_D = 20\ \mu\text{A}$	$-V_{G1S(p)}$	—	—	2,5	V
Gate 2 source pinch-off voltage $V_{DS} = 15\ \text{V}$, $V_{G1S} = 0$, $I_D = 20\ \mu\text{A}$	$-V_{G2S(p)}$	—	—	2,0	V

AC characteristics

Forward transconductance $V_{DS} = 15\ \text{V}$, $I_D = 10\ \text{mA}$, $V_{G2S} = 4\ \text{V}$, $f = 1\ \text{kHz}$	g_{fs}	15	18	—	mS
Gate 1 input capacitance $V_{DS} = 15\ \text{V}$, $I_D = 10\ \text{mA}$, $V_{G2S} = 4\ \text{V}$, $f = 1\ \text{MHz}$	C_{g1ss}	—	2,5	—	pF
Gate 2 input capacitance $V_{DS} = 15\ \text{V}$, $I_D = 10\ \text{mA}$, $V_{G2S} = 4\ \text{V}$, $f = 1\ \text{MHz}$	C_{g2ss}	—	1,2	—	pF
Feedback capacitance $V_{DS} = 15\ \text{V}$, $I_D = 10\ \text{mA}$, $V_{G2S} = 4\ \text{V}$, $f = 1\ \text{MHz}$	C_{dg1}	—	25	—	fF
Output capacitance $V_{DS} = 15\ \text{V}$, $I_D = 10\ \text{mA}$, $V_{G2S} = 4\ \text{V}$, $f = 1\ \text{MHz}$	C_{dss}	—	1	—	pF
Power gain $V_{DS} = 15\ \text{V}$, $I_D = 10\ \text{mA}$, $f = 200\ \text{MHz}$, $G_G = 2\ \text{mS}$, $G_L = 0,5\ \text{mS}$ (test circuit)	G_{ps}	—	25	—	dB
Noise figure $V_{DS} = 15\ \text{V}$, $I_D = 10\ \text{mA}$, $f = 200\ \text{MHz}$, $G_G = 2\ \text{mS}$, $G_L = 0,5\ \text{mS}$ (test circuit)	F	—	1	—	dB
Gain control range $V_{DS} = 15\ \text{V}$, $V_{G2S} = 4 \dots -2\ \text{V}$, $f = 200\ \text{MHz}$ (test circuit)	ΔG_{ps}	50	—	—	dB

Total power dissipation $P_{tot} = f(T_A)$

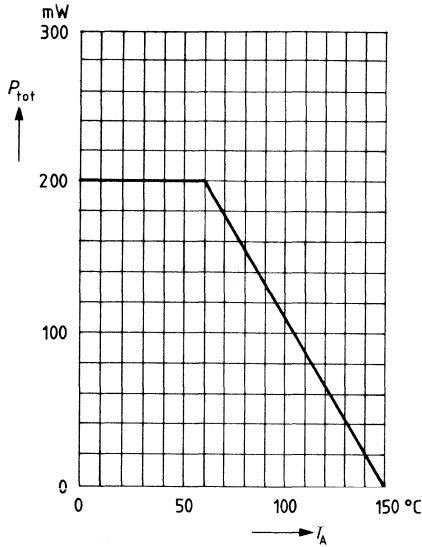

Output characteristics $I_D = f(V_{DS})$

$V_{G2S} = 4V$

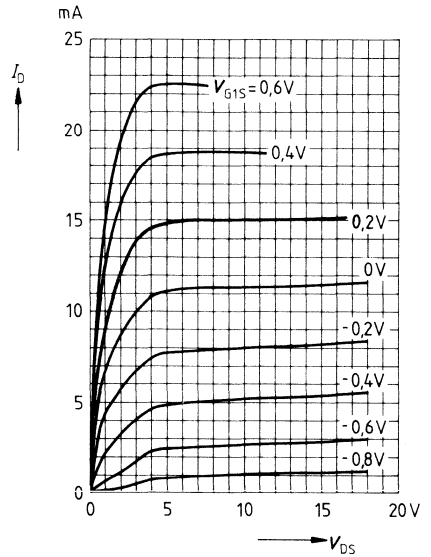

Gate 1 forward transconductance

$g_{fs1} = f(V_{G1S})$

$V_{DS} = 15V$

$I_{DSS} = 10mA, f = 1kHz$

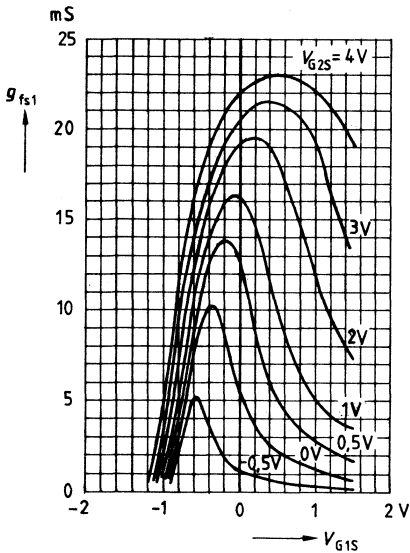

Gate 1 forward transconductance

$g_{fs1} = f(V_{G2S})$

$V_{DS} = 15V$

$I_{DSS} = 10mA, f = 1kHz$

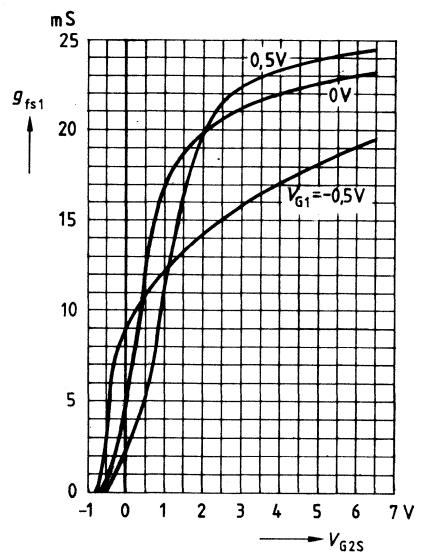

Drain current $I_D = f(V_{G1S})$

$V_{DS} = 15 \text{ V}$

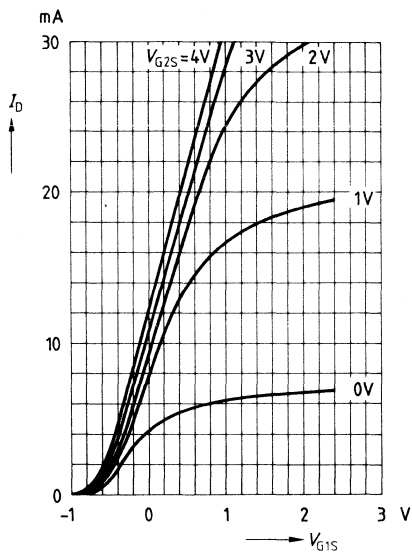

Gate 1 input capacitance $c_{g1ss} = f(V_{G1S})$

$V_{G2S} = 4 \text{ V}, V_{DS} = 15 \text{ V}$

$I_{DSS} = 10 \text{ mA}, f = 1 \text{ MHz}$

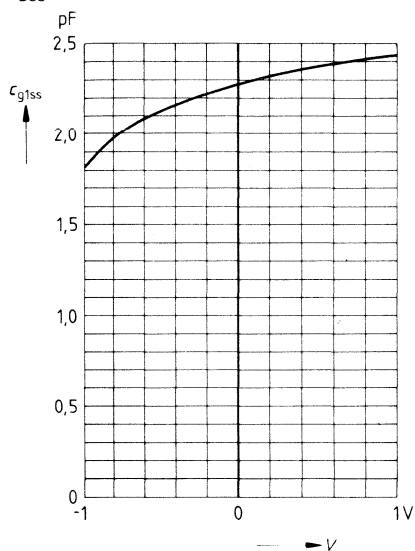

Gate 2 input capacitance $c_{g2ss} = f(V_{G2S})$

$V_{G1S} = 0 \text{ V}, V_{DS} = 15 \text{ V}$

$I_{DSS} = 10 \text{ mA}, f = 1 \text{ MHz}$

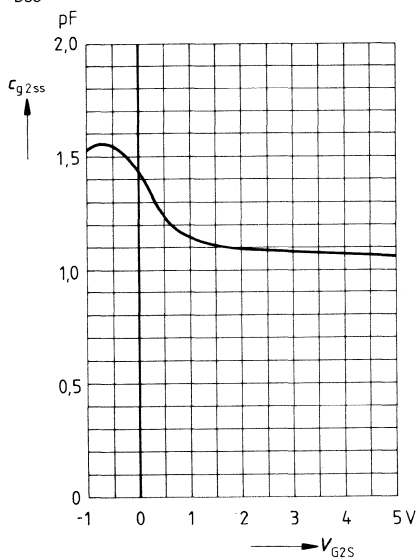

Output capacitance $c_{dss} = f(V_{DS})$

$V_{G1S} = 0 \text{ V}, V_{G2S} = 4 \text{ V}$

$I_{DSS} = 10 \text{ mA}, f = 1 \text{ MHz}$

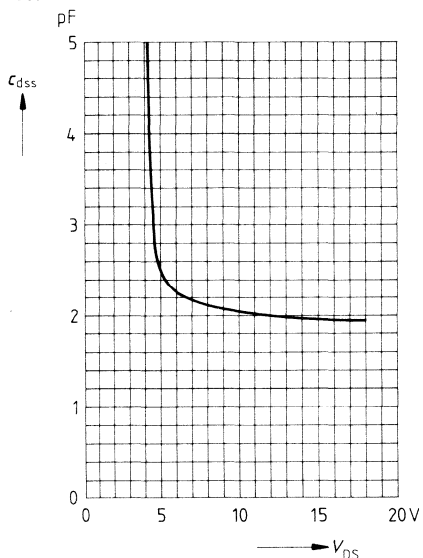

Gate 1 input admittance y_{11s}

$V_{DS} = 15\text{ V}$, $V_{G2S} = 4\text{ V}$, $V_{G1S} = 0\text{ V}$
 $I_{DSS} = 10\text{ mA}$ (common source)

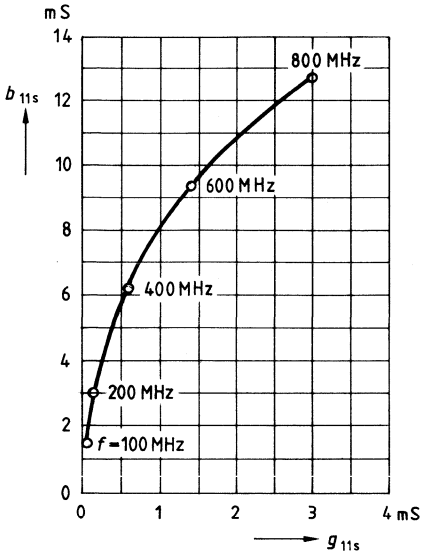

Gate 1 forward transfer admittance y_{21s}

$V_{DS} = 15\text{ V}$, $V_{G2S} = 4\text{ V}$, $V_{G1S} = 0\text{ V}$
 $I_{DSS} = 10\text{ mA}$ (common source)

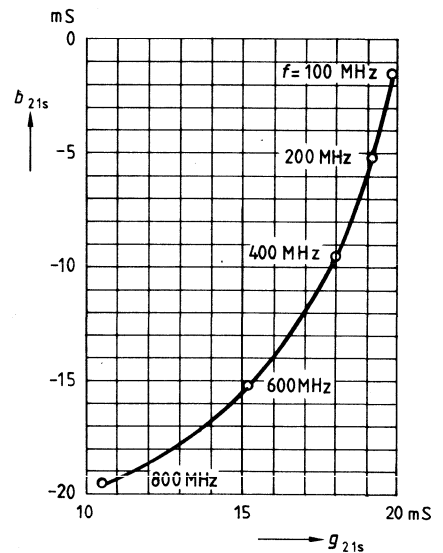

Output admittance y_{22s}

$V_{DS} = 15\text{ V}$, $V_{G2S} = 4\text{ V}$, $V_{G1S} = 0\text{ V}$
 $I_{DSS} = 10\text{ mA}$ (common source)

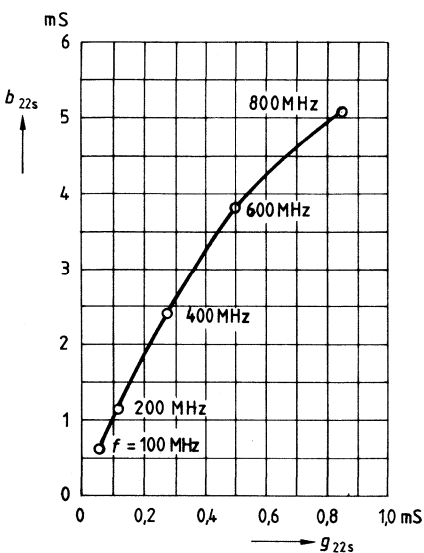

Power gain $G_{ps} = f(V_{G2S})$

$V_{DS} = 15\text{ V}$, $V_{G1S} = 0\text{ V}$, $I_{DSS} = 10\text{ mA}$
 $f = 200\text{ MHz}$ (see test circuit)

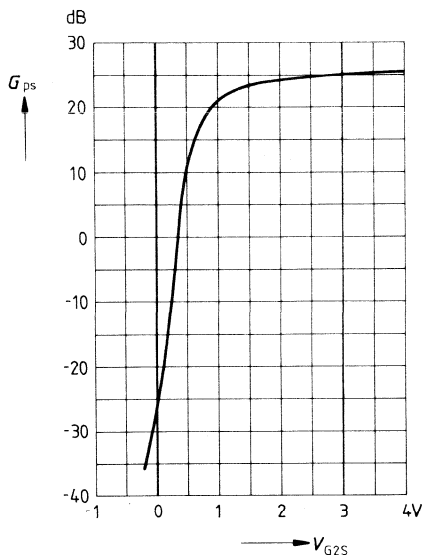

Noise figure $F = f(V_{G2S})$

$V_{DS} = 15\text{ V}$, $V_{G1S} = 0\text{ V}$, $I_{DSS} = 10\text{ mA}$
 $f = 200\text{ MHz}$ (see test circuit)

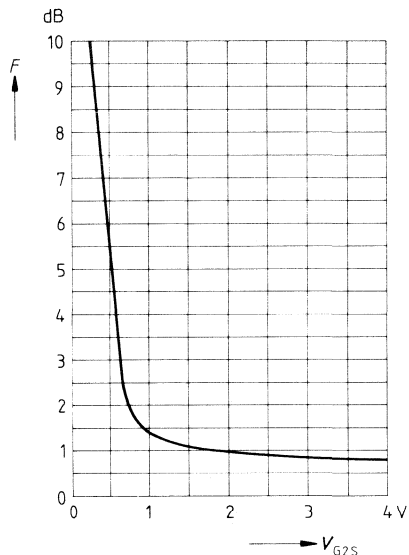

Test circuit for power gain and noise figure

$f = 200\text{ MHz}$, $G_G = 2\text{ mS}$, $G_L = 0,5\text{ mS}$

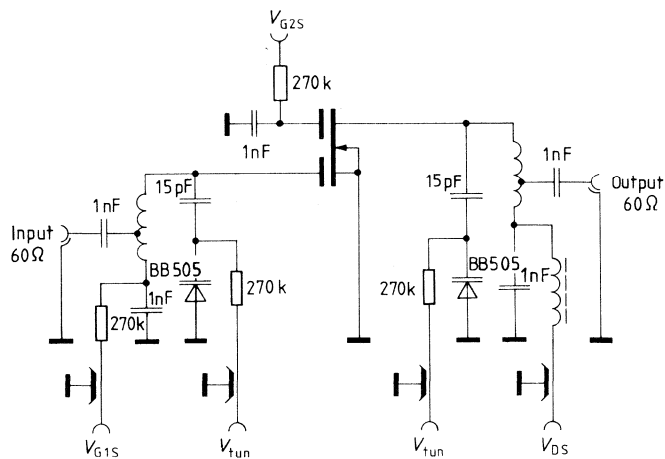

- For input stages in UHF TV tuners
- High transconductance
- Low noise figure

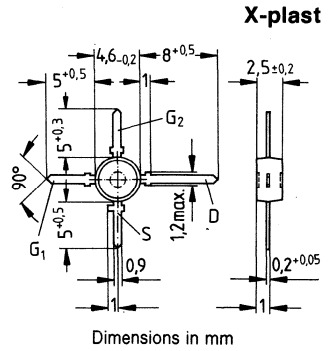

Type	BF 966 S
Ordering code	Q62702-F438

Maximum ratings

Drain-source voltage	V_{DS}	20	V
Drain current	I_D	30	mA
Gate 1/gate 2 peak source current	$\pm I_{G1/2SM}$	10	mA
Total power dissipation $T_A \leq 60^\circ C$	P_{tot}	200	mW
Storage temperature range	T_{stg}	-55... +150	$^\circ C$
Channel temperature	T_{Ch}	150	$^\circ C$

Thermal resistance

Junction — ambient	R_{thJA}	≤ 450	K/W
--------------------	------------	------------	-----

Characteristics ($T_A = 25^\circ\text{C}$)

DC characteristics

		min	typ	max	
Drain-source breakdown voltage $I_D = 10\ \mu\text{A}$, $-V_{G1S} = -V_{G2S} = 4\ \text{V}$	$V_{(BR)DS}$	20	—	—	V
Gate 1 source breakdown voltage $\pm I_{G1S} = 10\ \text{mA}$, $V_{G2S} = V_{DS} = 0$	$\pm V_{(BR)G1SS}$	8,5	—	17	V
Gate 2 source breakdown voltage $\pm I_{G2S} = 10\ \text{mA}$, $V_{G1S} = V_{DS} = 0$	$\pm V_{(BR)G2SS}$	8,5	—	17	V
Gate 1 source leakage current $\pm V_{G1S} = 5\ \text{V}$, $V_{G2S} = V_{DS} = 0$	$\pm I_{G1SS}$	—	—	50	nA
Gate 2 source leakage current $\pm V_{G2S} = 5\ \text{V}$, $V_{G1S} = V_{DS} = 0$	$\pm I_{G2SS}$	—	—	50	nA
Drain current $V_{DS} = 15\ \text{V}$, $V_{G1S} = 0$, $V_{G2S} = 4\ \text{V}$	I_{DSS}	2	—	20	mA
Gate 1 source pinch-off voltage $V_{DS} = 15\ \text{V}$, $V_{G2S} = 4\ \text{V}$, $I_D = 20\ \mu\text{A}$	$-V_{G1S(p)}$	—	—	2,5	V
Gate 2 source pinch-off voltage $V_{DS} = 15\ \text{V}$, $V_{G1S} = 0$, $I_D = 20\ \mu\text{A}$	$-V_{G2S(p)}$	—	—	2	V

AC characteristics

Forward transconductance $V_{DS} = 15\ \text{V}$, $I_D = 10\ \text{mA}$, $V_{G2S} = 4\ \text{V}$, $f = 1\ \text{kHz}$	g_{fs}	15	18	—	mS
Gate 1 input capacitance $V_{DS} = 15\ \text{V}$, $I_D = 10\ \text{mA}$, $V_{G2S} = 4\ \text{V}$, $f = 1\ \text{MHz}$	C_{g1ss}	—	2,3	—	pF
Gate 2 input capacitance $V_{DS} = 15\ \text{V}$, $I_D = 10\ \text{mA}$, $V_{G2S} = 4\ \text{V}$, $f = 1\ \text{MHz}$	C_{g2ss}	—	1,1	—	pF
Feedback capacitance $V_{DS} = 15\ \text{V}$, $I_D = 10\ \text{mA}$, $V_{G2S} = 4\ \text{V}$, $f = 1\ \text{MHz}$	C_{dg1}	—	25	—	fF
Output capacitance $V_{DS} = 15\ \text{V}$, $I_D = 10\ \text{mA}$, $V_{G2S} = 4\ \text{V}$, $f = 1\ \text{MHz}$	C_{dss}	—	0,8	—	pF
Power gain $V_{DS} = 15\ \text{V}$, $I_D = 10\ \text{mA}$ $f = 200\ \text{MHz}$, $G_G = 2\ \text{mS}$, $G_L = 0,5\ \text{mS}$ (test circuit 1)	G_{ps}	—	25	—	dB
$f = 800\ \text{MHz}$, $G_G = 3,3\ \text{mS}$, $G_L = 1\ \text{mS}$ (test circuit 2)		—	18	—	dB
Noise figure $V_{DS} = 15\ \text{V}$, $I_D = 10\ \text{mA}$ $f = 200\ \text{MHz}$, $G_G = 2\ \text{mS}$, $G_L = 0,5\ \text{mS}$ (test circuit 1)	F	—	1	—	dB
$f = 800\ \text{MHz}$, $G_G = 3,3\ \text{mS}$, $G_L = 1\ \text{mS}$ (test circuit 2)		—	1,8	—	dB
Gain control range $V_{DS} = 15\ \text{V}$, $V_{G2S} = 4 \dots -2\ \text{V}$, $f = 800\ \text{MHz}$ (test circuit 2)	ΔG_{ps}	40	—	—	dB

Total power dissipation $P_{tot} = f(T_A)$

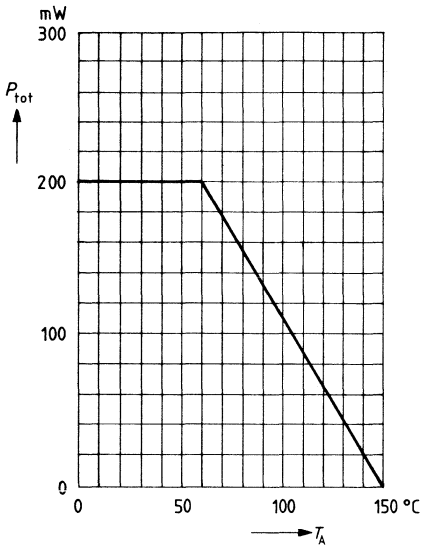

Output characteristics $I_D = f(V_{DS})$

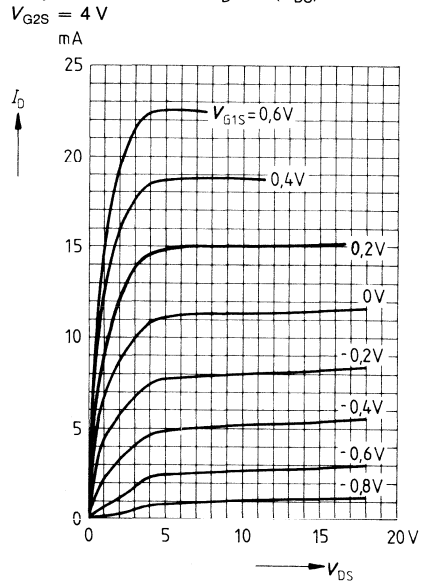

Gate 1 forward transconductance

$g_{fs1} = f(V_{G1S})$
 $V_{DS} = 15V$
 $I_{DSS} = 10mA, f = 1kHz$

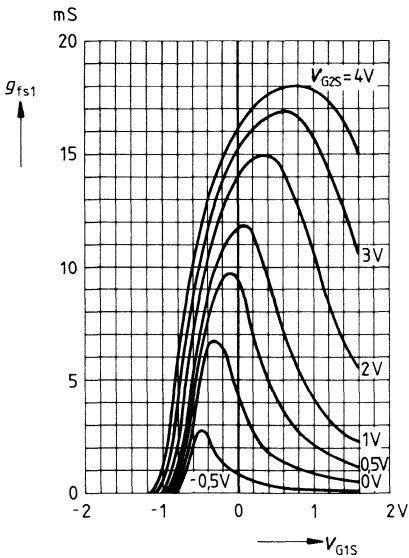

Gate 1 forward transconductance

$g_{fs1} = f(V_{G2S})$
 $V_{DS} = 15V$
 $I_{DSS} = 10mA, f = 1kHz$

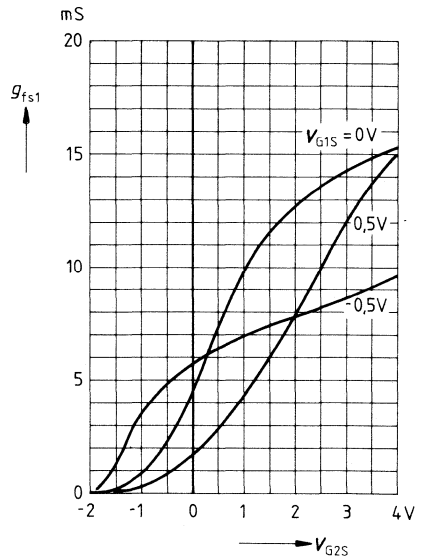

Drain current $I_D = f(V_{G1S})$

$V_{DS} = 15\text{ V}$

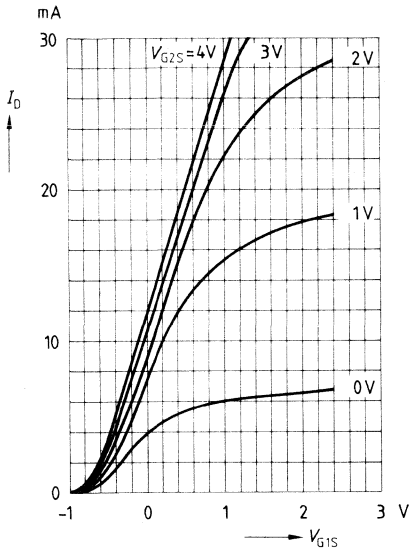

Gate 1 input capacitance $C_{g1ss} = f(V_{G1S})$

$V_{G2S} = 4\text{ V}, V_{DS} = 15\text{ V}$
 $I_{DSS} = 10\text{ mA}, f = 1\text{ MHz}$

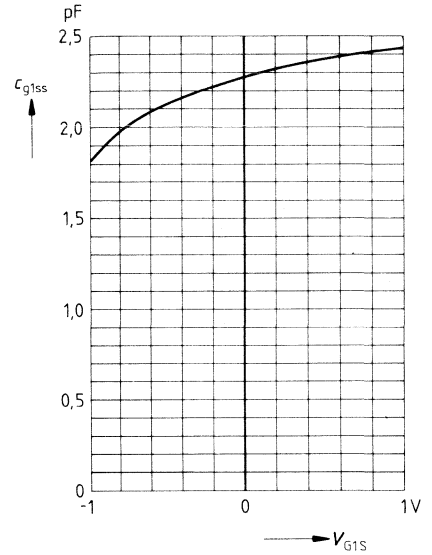

Gate 2 input capacitance $C_{g2ss} = f(V_{G2S})$

$V_{G1S} = 0\text{ V}, V_{DS} = 15\text{ V}$
 $I_{DSS} = 10\text{ mA}, f = 1\text{ MHz}$

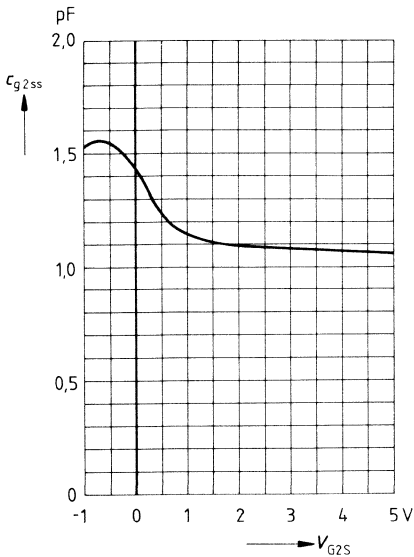

Output capacitance $C_{dss} = f(V_{DS})$

$V_{G1S} = 0\text{ V}, V_{G2S} = 4\text{ V}$
 $I_{DSS} = 10\text{ mA}, f = 1\text{ MHz}$

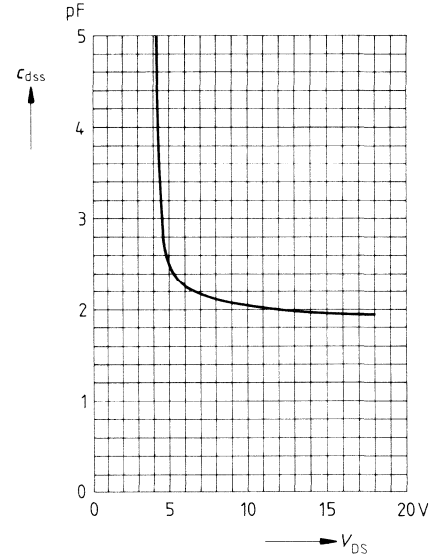

Power gain $G_{ps} = f(V_{G2S})$

$V_{DS} = 15\text{ V}$, $V_{G1S} = 0\text{ V}$, $I_{DSS} = 10\text{ mA}$
 $f = 200\text{ MHz}$ (see test circuit 1)

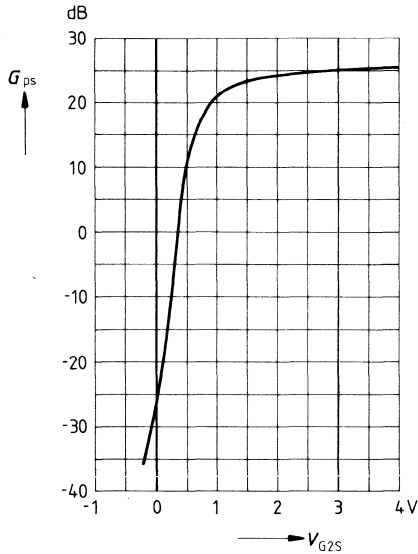

Noise figure $F = f(V_{G2S})$

$V_{DS} = 15\text{ V}$, $V_{G1S} = 0\text{ V}$, $I_{DSS} = 10\text{ mA}$
 $f = 200\text{ MHz}$ (see test circuit 1)

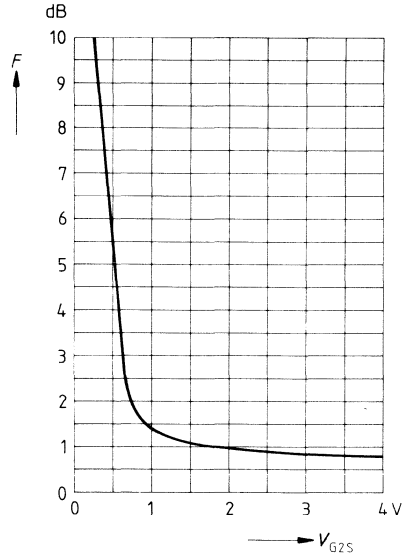

Power gain $G_{ps} = f(V_{G2S})$

$V_{DS} = 15\text{ V}$, $V_{G1S} = 0\text{ V}$, $I_{DSS} = 10\text{ mA}$
 $f = 800\text{ MHz}$ (see test circuit 2)

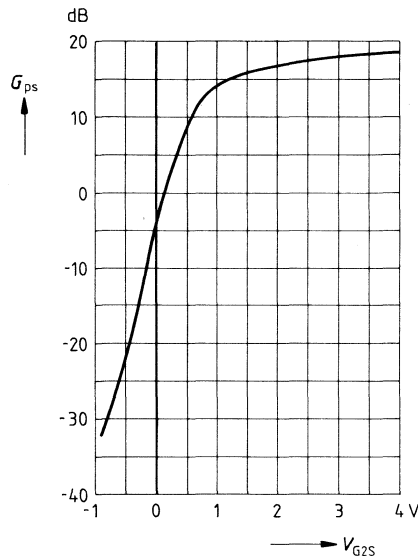

Noise figure $F = f(V_{G2S})$

$V_{DS} = 15\text{ V}$, $V_{G1S} = 0\text{ V}$, $I_{DSS} = 10\text{ mA}$
 $f = 800\text{ MHz}$ (see test circuit 2)

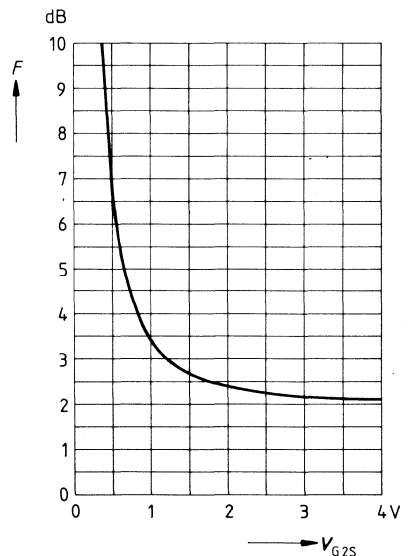

Gate 1 input admittance y_{11s}

$V_{DS} = 15\text{ V}$, $V_{G2S} = 4\text{ V}$
(common source)

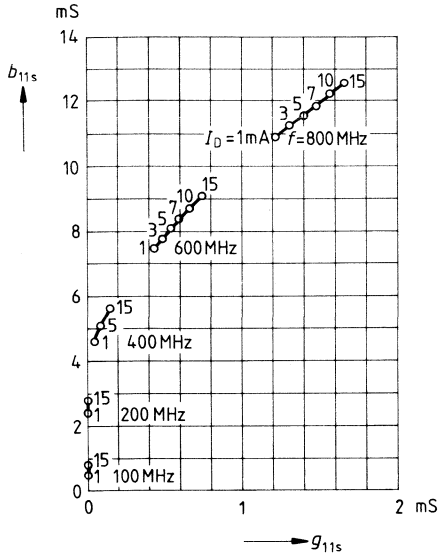

Gate 1 forward transfer admittance y_{21s}

$V_{DS} = 15\text{ V}$, $V_{G2S} = 4\text{ V}$
(common source)

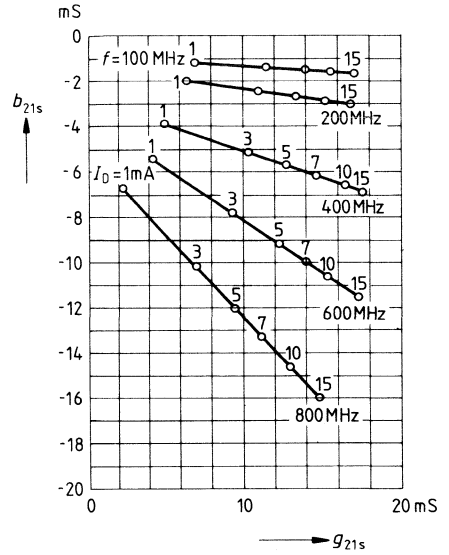

Output admittance y_{22s}

$V_{DS} = 15\text{ V}$, $V_{G2S} = 4\text{ V}$
(common source)

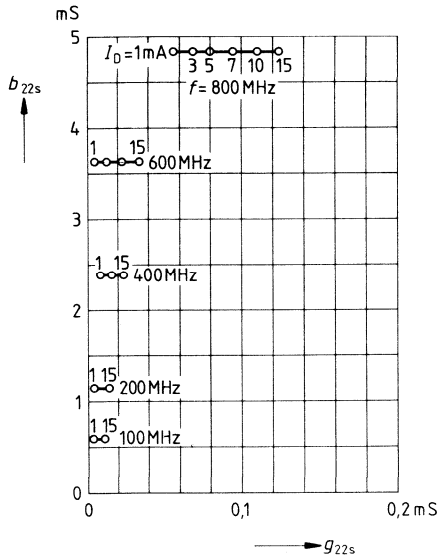

Test circuit 1 for power gain and noise figure

$f = 200 \text{ MHz}$, $G_G = 2 \text{ mS}$, $G_L = 0,5 \text{ mS}$

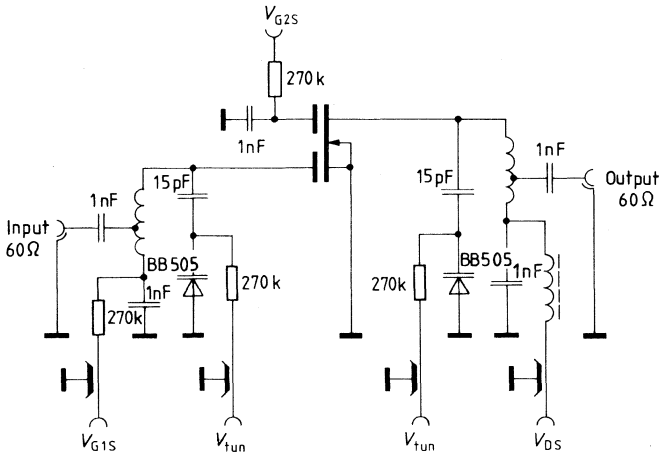

Test circuit 2 for power gain, noise figure and cross modulation

$f = 800 \text{ MHz}$, $G_G = 3,3 \text{ mS}$, $G_L = 1,0 \text{ mS}$

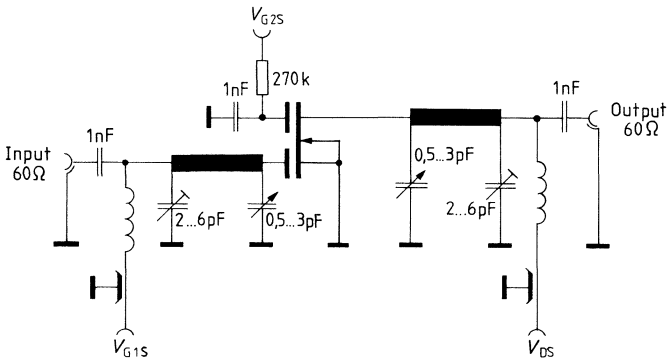

- For UHF mixer and oscillator stages

T-plast

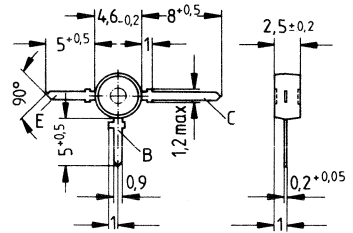

Dimensions in mm

Type	BF 970
Ordering code	Q62702-F611

Maximum ratings

- Collector-emitter voltage
- Collector-base voltage
- Emitter-base voltage
- Collector current
- Base current
- Total power dissipation ($T_A \leq 50^\circ\text{C}$)
- Junction temperature
- Storage temperature range

V_{CE0}	35	V
V_{CBO}	40	V
V_{EBO}	3	V
I_C	30	mA
I_B	5	mA
P_{tot}	160	mW
T_j	150	$^\circ\text{C}$
T_{stg}	- 50... + 150	$^\circ\text{C}$

Thermal resistance

- Junction — ambient

R_{thJA}	≤ 600	K/W
------------	------------	-----

Characteristics ($T_A = 25^\circ\text{C}$)

DC characteristics		min	typ	max	
Collector cutoff current $V_{CB} = 20\text{ V}$	I_{CBO}	—	—	100	nA
DC current gain $I_C = 3\text{ mA}, V_{CE} = 10\text{ V}$	h_{FE}	25	50	—	—
AC characteristics					
Transition frequency $I_C = 3\text{ mA}, V_{CE} = 10\text{ V}, f = 100\text{ MHz}$	f_T	—	950	—	MHz
Output capacitance $V_{CB} = 10\text{ V}, I_E = 0, f = 1\text{ MHz}$	c_{obo}	—	0,45	—	pF
Collector-emitter capacitance $V_{CB} = 1\text{ V}, V_{BE} = 0, f = 1\text{ MHz}$	c_{ce}	—	0,1	—	pF
Noise figure $I_C = 3\text{ mA}, V_{CB} = 10\text{ V}, f = 800\text{ MHz}$ $R_S = 60\ \Omega$	F	—	4,5	—	dB
Common base power gain $I_C = 3\text{ mA}, V_{CB} = 10\text{ V}, f = 800\text{ MHz}$ $R_L = 500\ \Omega$	G_{pb}	—	14,8	—	dB
Collector current for $G_{pb\max}$ $V_{CC} = 12\text{ V}, R_{CC} = 1\text{ k}\Omega, f = 800\text{ MHz}$ $R_L = 500\ \Omega$	$I_{CG\max}$	—	4,5	—	mA

- For low-distortion, low-noise UHF input stages and UHF oscillators

T-plast

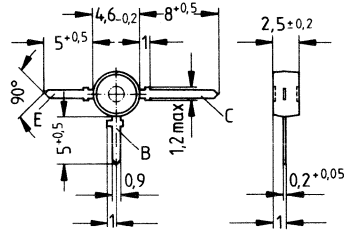

Dimensions in mm

Type	BF 979 S
Ordering code	Q62702-F610

Maximum ratings

- Collector-emitter voltage
- Collector-base voltage
- Emitter-base voltage
- Peak collector current
- Total power dissipation ($T_A \leq 50^\circ\text{C}$)
- Junction temperature
- Storage temperature range

V_{CE0}	25	V
V_{CBO}	30	V
V_{EBO}	3	V
I_{CM}	50	mA
P_{tot}	160	mW
T_j	150	$^\circ\text{C}$
T_{stg}	-50...+150	$^\circ\text{C}$

Thermal resistance

- Junction — ambient

R_{thJA}	≤ 600	K/W
------------	------------	-----

Characteristics ($T_A = 25^\circ\text{C}$)

DC characteristics		min	typ	max	
Collector cutoff current $V_{CB} = 20\text{ V}$	I_{CBO}	—	—	100	nA
DC current gain $I_C = 10\text{ mA}, V_{CE} = 10\text{ V}$	h_{FE}	20	—	—	—

AC characteristics					
Transition frequency $I_C = 10\text{ mA}, V_{CE} = 10\text{ V}, f = 100\text{ MHz}$	f_T	—	1,6	—	GHz
Output capacitance $V_{CB} = 10\text{ V}, f = 1\text{ MHz}$	c_{obo}	—	0,55	—	pF
Collector-emitter capacitance $V_{CB} = 1\text{ V}, V_{BE} = 0, f = 1\text{ MHz}$	c_{ce}	—	0,09	—	pF
Noise figure $I_C = 10\text{ mA}, V_{CB} = 10\text{ V}, R_S = 60\ \Omega$ $f = 200\text{ MHz}$ 800 MHz	F	—	3	—	dB
		—	3,5	4,5	dB
Power gain $I_C = 10\text{ mA}, V_{CB} = 10\text{ V}, f = 800\text{ MHz}$ $R_L = 500\ \Omega$	G_{pb}		16,5		dB
Interference voltage ¹⁾ $I_C = 10\text{ mA}, V_{CB} = 10\text{ V}, f = 200\text{ MHz}$ $R_S = 75\ \Omega$	$V_{1\%}$	—	230	—	mV
Collector current for $G_{pb\max}$ $V_{CB} = 10\text{ V}, f = 800\text{ MHz}, R_L = 500\ \Omega$	$I_{CG\max}$	10	—	—	mA

¹⁾ $V_{1\%}$ is the rms value of half the emf (terminal voltage at matching) of a 100% sine modulated TV carrier at an internal generator resistance of $60\ \Omega$, causing 1% amplitude modulation on the active carrier.

- For amplifier and mixer stages in UHF and VHF TV tuners
- Low input and output capacitance
- Miniature plastic package for surface mounting (SMD)

SOT 143

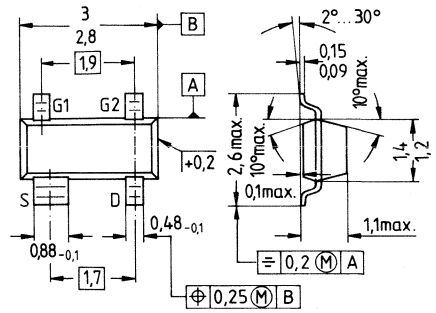

Dimensions in mm

Type	BF 989	
Ordering code	bulk: Q62702-F874	taped: Q62702-F969
Marking	MA	

Maximum ratings

Drain-source voltage	V_{DS}	20	V
Drain current	I_D	30	mA
Gate 1/gate 2 peak source current	$\pm I_{G1/2SM}$	10	mA
Total power dissipation	P_{tot}	200	mW
$T_A \leq 60^\circ C$			
Storage temperature range	T_{stg}	-55... + 150	$^\circ C$
Channel temperature	T_{Ch}	150	$^\circ C$

Thermal resistance

Junction — ambient	R_{thJA}	≤ 450	K/W
--------------------	------------	------------	-----

Characteristics ($T_A = 25^\circ\text{C}$)

DC characteristics		min	typ	max	
Drain-source breakdown voltage $I_D = 10\ \mu\text{A}$, $-V_{G1S} = -V_{G2S} = 4\ \text{V}$	$V_{(BR)DS}$	20	—	—	V
Gate 1 source breakdown voltage $\pm I_{G1S} = 10\ \text{mA}$, $V_{G2S} = V_{DS} = 0$	$\pm V_{(BR)G1SS}$	8,5	—	17	V
Gate 2 source breakdown voltage $\pm I_{G2S} = 10\ \text{mA}$, $V_{G1S} = V_{DS} = 0$	$\pm V_{(BR)G2SS}$	8,5	—	17	V
Gate 1 source leakage current $\pm V_{G1S} = 5\ \text{V}$, $V_{G2S} = V_{DS} = 0$	$\pm I_{G1SS}$	—	—	50	nA
Gate 2 source leakage current $\pm V_{G2S} = 5\ \text{V}$, $V_{G1S} = V_{DS} = 0$	$\pm I_{G2SS}$	—	—	50	nA
Drain current $V_{DS} = 15\ \text{V}$, $V_{G1S} = 0$, $V_{G2S} = 4\ \text{V}$	I_{DSS}	2	—	20	mA
Gate 1 source pinch-off voltage $V_{DS} = 15\ \text{V}$, $V_{G2S} = 4\ \text{V}$, $I_D = 20\ \mu\text{A}$	$-V_{G1S(p)}$	—	—	2,7	V
Gate 2 source pinch-off voltage $V_{DS} = 15\ \text{V}$, $V_{G1S} = 0$, $I_D = 20\ \mu\text{A}$	$-V_{G2S(p)}$	—	—	2,7	V

Characteristics ($T_A = 25^\circ\text{C}$)

AC characteristics

		min	typ	max	
Forward transconductance $V_{DS} = 15\text{ V}, I_D = 7\text{ mA}, V_{G2S} = 4\text{ V}, f = 1\text{ kHz}$	g_{fs}	9,5	12	—	mS
Gate 1 input capacitance $V_{DS} = 15\text{ V}, I_D = 7\text{ mA}, V_{G2S} = 4\text{ V}, f = 1\text{ MHz}$	C_{g1ss}	—	1,8	—	pF
Gate 2 input capacitance $V_{DS} = 15\text{ V}, I_D = 7\text{ mA}, V_{G2S} = 4\text{ V}, f = 1\text{ MHz}$	C_{g2ss}	—	1	—	pF
Feedback capacitance $V_{DS} = 15\text{ V}, I_D = 7\text{ mA}, V_{G2S} = 4\text{ V}, f = 1\text{ MHz}$	C_{dg1}	—	25	—	fF
Output capacitance $V_{DS} = 15\text{ V}, I_D = 7\text{ mA}, V_{G2S} = 4\text{ V}, f = 1\text{ MHz}$	C_{dss}	—	0,8	—	pF
Power gain $V_{DS} = 15\text{ V}, I_D = 7\text{ mA}$ $f = 200\text{ MHz}, G_G = 2\text{ mS}, G_L = 0,5\text{ mS}$ (test circuit 1)	G_{ps}	—	23	—	dB
$f = 800\text{ MHz}, G_G = 2,5\text{ mS}, G_L = 0,8\text{ mS}$ (test circuit 2)		—	16,5	—	dB
Noise figure $V_{DS} = 15\text{ V}, I_D = 7\text{ mA}$ $f = 200\text{ MHz}, G_G = 2\text{ mS}, G_L = 0,5\text{ mS}$ (test circuit 1)	F	—	1,6	—	dB
$f = 800\text{ MHz}, G_G = 2,5\text{ mS}, G_L = 0,8\text{ mS}$ (test circuit 2)		—	2,8	—	dB
Gain control range $V_{DS} = 15\text{ V}, V_{G2S} = 4 \dots -2\text{ V}, f = 800\text{ MHz}$	ΔG_{ps}	40	—	—	dB
Mixer gain $V_{DS} = 15\text{ V}, V_{G2S} = 4\text{ V}, f = 800\text{ MHz}$ $f_{IF} = 36\text{ MHz}, 2 \Delta f_{IF} = 5\text{ MHz}$ $V_{osc} = 800\text{ mV}$ (test circuit 3)	G_{psc}	—	16	—	dB

Total power dissipation $P_{tot} = f(T_A)$

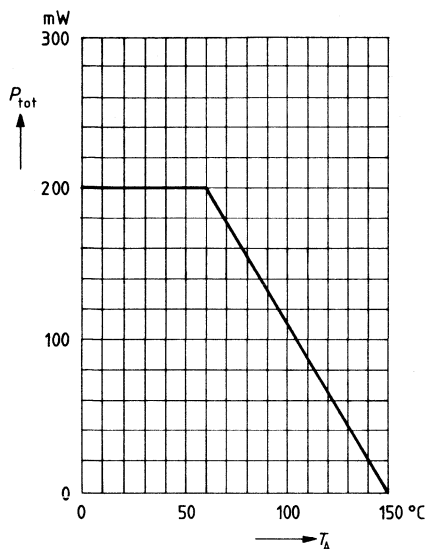

Output characteristics $I_D = f(V_{DS})$

$V_{G2S} = 4\text{ V}$

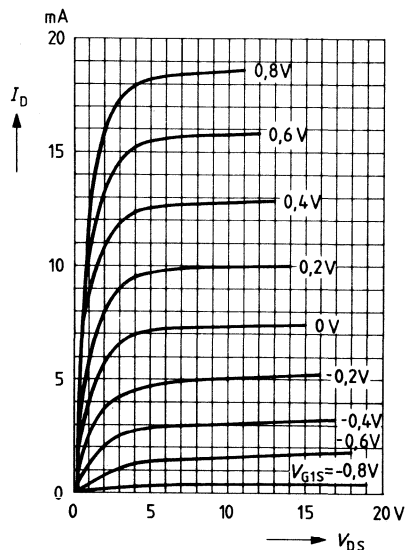

Gate 1 forward transconductance

$g_{fs1} = f(V_{G1S})$

$V_{DS} = 15\text{ V}$

$I_{DSS} = 7\text{ mA}, f = 1\text{ kHz}$

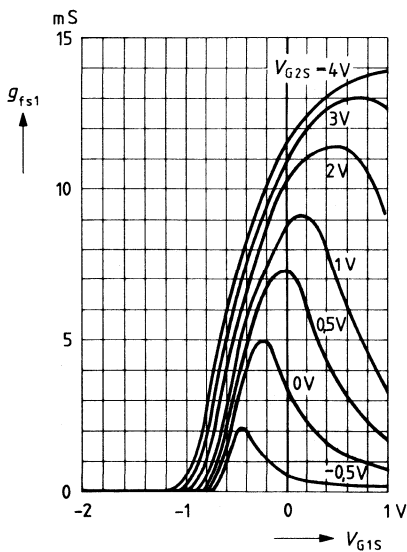

Gate 1 forward transconductance

$g_{fs1} = f(V_{G2S})$

$V_{DS} = 15\text{ V}$

$I_{DSS} = 7\text{ mA}, f = 1\text{ kHz}$

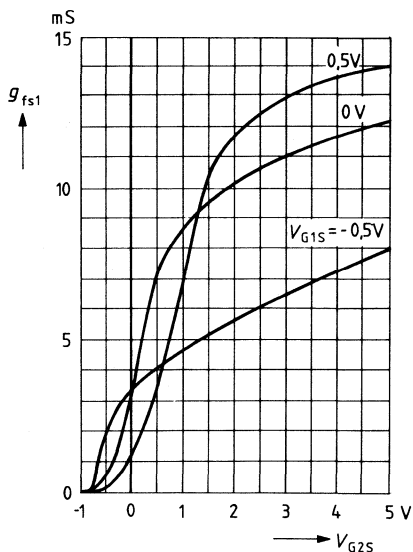

Drain current $I_D = f(V_{G1S})$

$V_{DS} = 15\text{ V}$

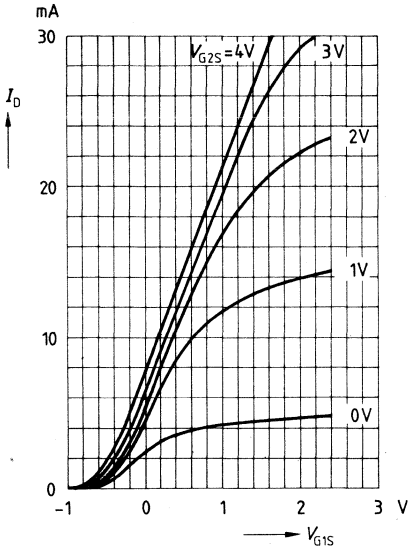

Gate 1 input capacitance $c_{g1ss} = f(V_{G1S})$

$V_{G2S} = 4\text{ V}, V_{DS} = 15\text{ V}$

$I_{DSS} = 7\text{ mA}, f = 1\text{ MHz}$

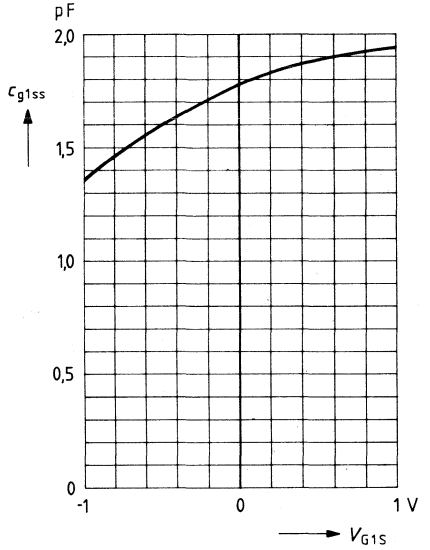

Gate 2 input capacitance $c_{g2ss} = f(V_{G2S})$

$V_{G1S} = 0\text{ V}, V_{DS} = 15\text{ V}$

$I_{DSS} = 7\text{ mA}, f = 1\text{ MHz}$

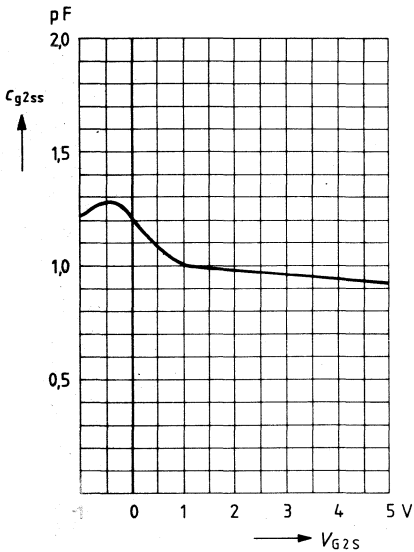

Output capacitance $c_{dss} = f(V_{DS})$

$V_{G1S} = 0\text{ V}, V_{G2S} = 4\text{ V}$

$I_{DSS} = 7\text{ mA}, f = 1\text{ MHz}$

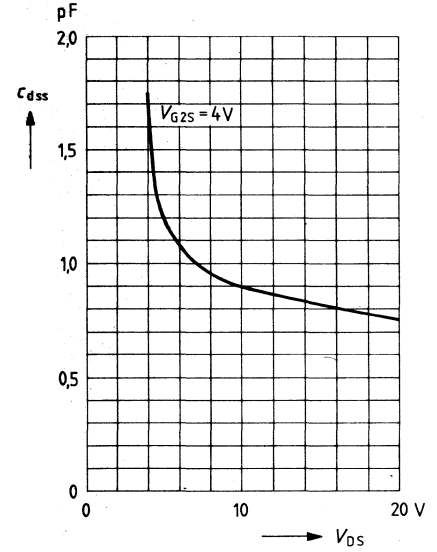

Gate 1 input admittance y_{11s}

$V_{DS} = 15\text{ V}$, $V_{G2S} = 4\text{ V}$
(common source)

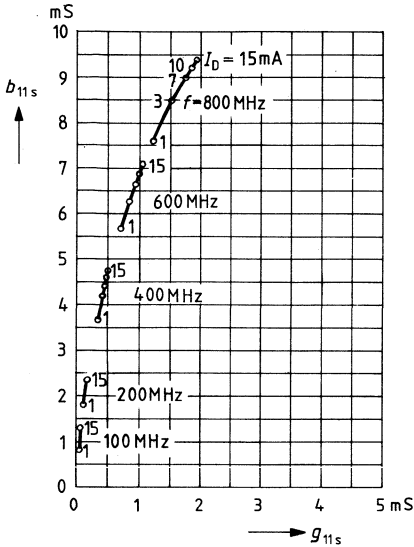

Gate 1 forward transfer admittance y_{21s}

$V_{DS} = 15\text{ V}$, $V_{G2S} = 4\text{ V}$
(common source)

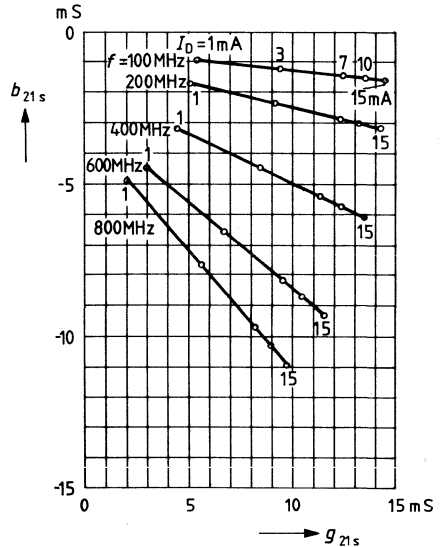

Output admittance y_{22s}

$V_{DS} = 15\text{ V}$, $V_{G2S} = 4\text{ V}$
(common source)

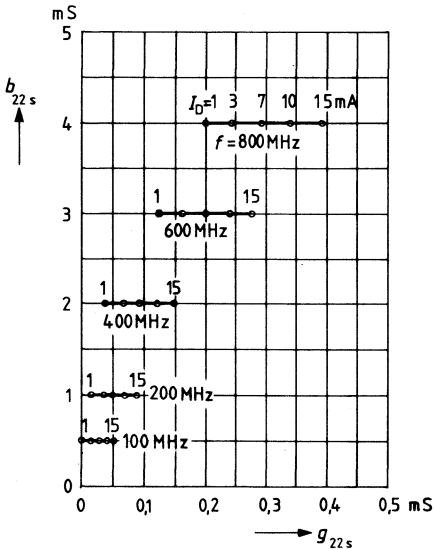

Power gain $G_{ps} = f(V_{G2S})$

$V_{DS} = 15\text{ V}$, $V_{G1S} = 0$, $I_{DSS} = 7\text{ mA}$
 $f = 200\text{ MHz}$ (see test circuit 1)

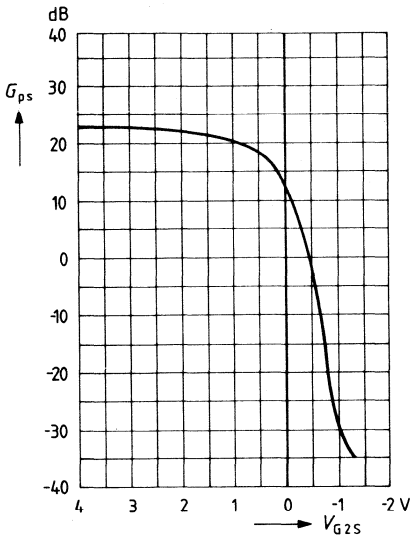

Noise figure $F = f(V_{G2S})$

$V_{DS} = 15\text{ V}$, $V_{G1S} = 0$, $I_{DSS} = 7\text{ mA}$
 $f = 200\text{ MHz}$ (see test circuit 1)

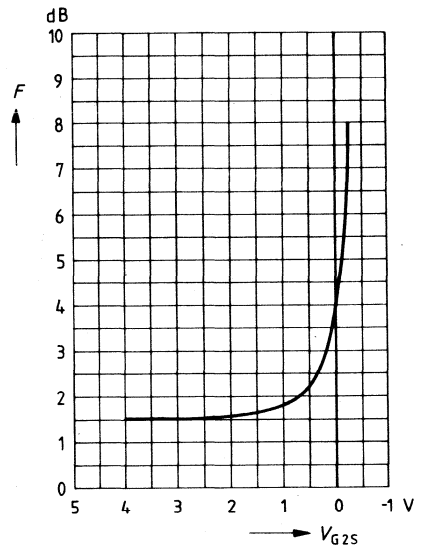

Power gain $G_{ps} = f(V_{G2S})$

$V_{DS} = 15\text{ V}$, $V_{G1S} = 0$, $I_{DSS} = 7\text{ mA}$
 $f = 800\text{ MHz}$, $R_S = 0$ (see test circuit 2)

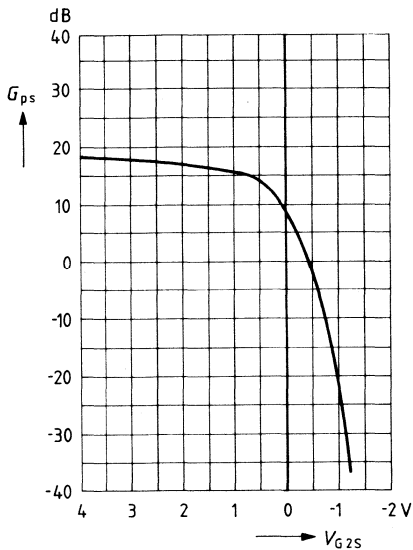

Noise figure $F = f(V_{G2S})$

$V_{DS} = 15\text{ V}$, $V_{G1S} = 0$, $I_{DSS} = 7\text{ mA}$
 $f = 800\text{ MHz}$, $R_S = 0$ (see test circuit 2)

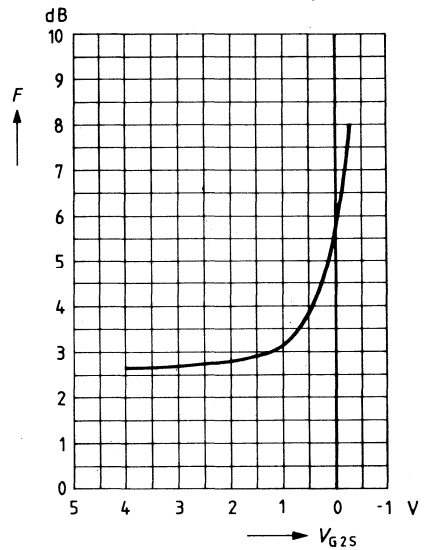

Interference voltage for 1% cross modulation

$V_{int(1\%)} = f(f_{int})^1$
 $V_{DS} = 15\text{ V}, V_{G2S} = 4\text{ V}, V_{G1S} = 1\text{ V}$
 $f = 800\text{ MHz}$ (see test circuit 2)

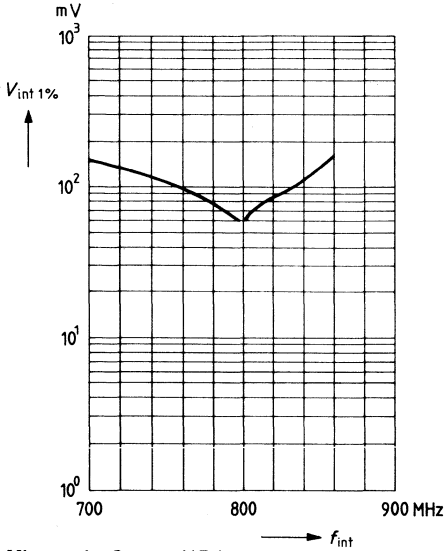

Interference voltage for 1% cross modulation

$V_{int(1\%)} = f(\Delta G_{ps})^1$
 $V_{DS} = 15\text{ V}, V_{G1S} = 1\text{ V}, f = 800\text{ MHz}$
 $f_{int} = 700\text{ MHz}$ (see test circuit 2)

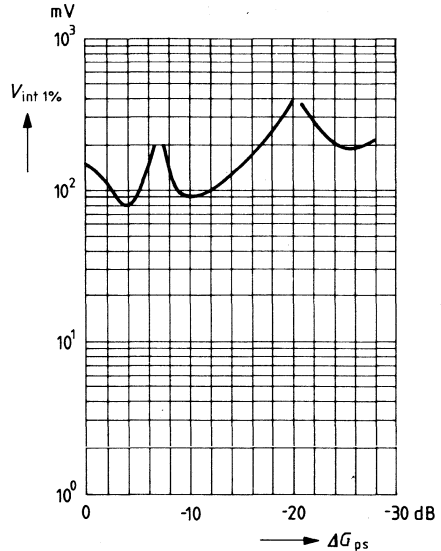

Mixer gain $G_{psc} = f(R_S)$

$f = 800\text{ MHz}, f_{osc} = 836\text{ MHz}, V_{osc} = 800\text{ mV}$
 $V_{DS} = 15\text{ V}, V_{G2S} = 4\text{ V}, I_{DSS} = 7\text{ mA}$
 (see test circuit 3)

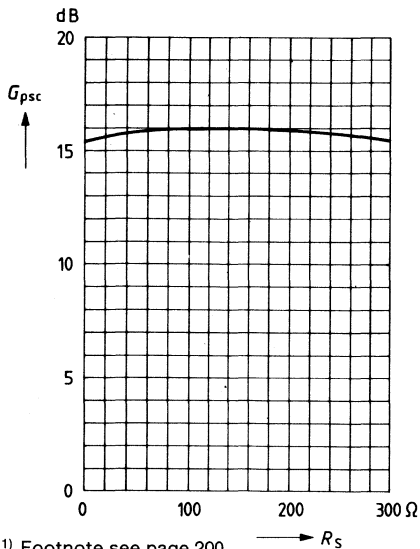

Mixer gain $G_{psc} = f(V_{osc})$

$f = 800\text{ MHz}, f_{osc} = 836\text{ MHz}, R_S = 150\ \Omega$
 $V_{DS} = 15\text{ V}, V_{G2S} = 4\text{ V}, I_{DSS} = 7\text{ mA}$
 (see test circuit 3)

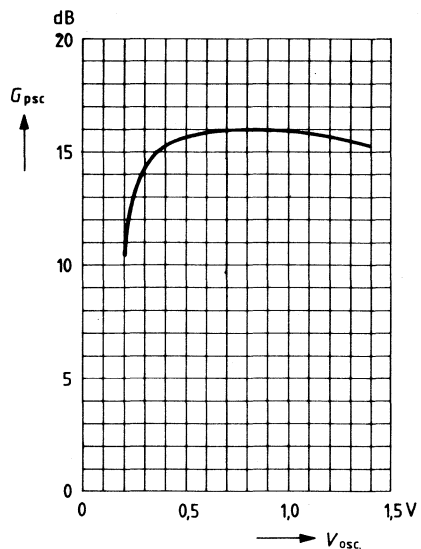

¹⁾ Footnote see page 200

Test circuit 1 for power gain and noise figure

$f = 200 \text{ MHz}$, $G_G = 2 \text{ mS}$, $G_L = 0,5 \text{ mS}$

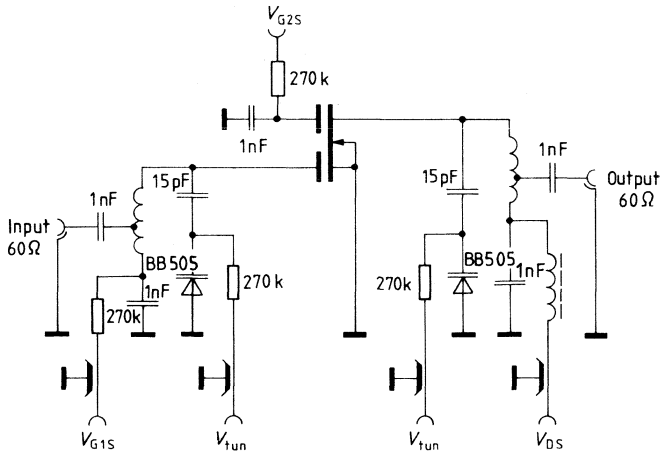

Test circuit 2 for power gain, noise figure and cross modulation

$f = 800 \text{ MHz}$, $G_G = 2,5 \text{ mS}$, $G_L = 0,8 \text{ mS}$

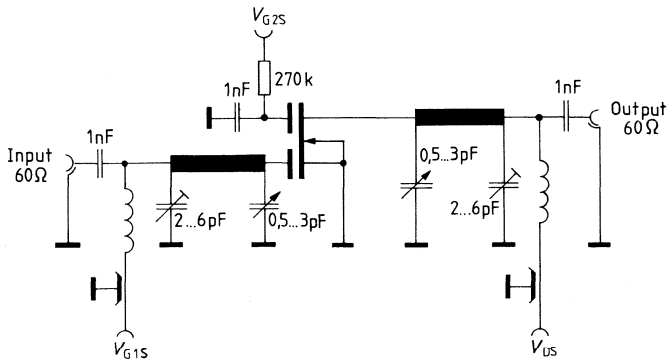

Test circuit 3 for mixer gain

$f = 800/36 \text{ MHz}$

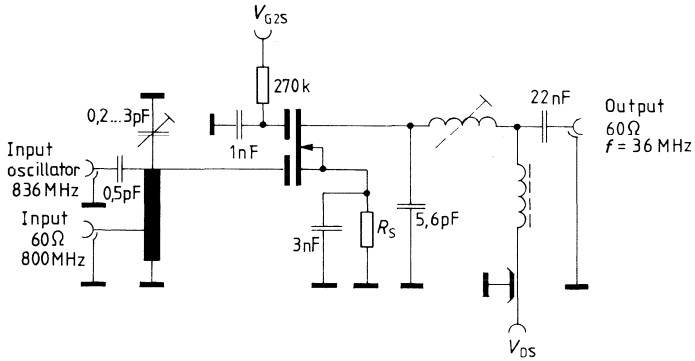

1) $V_{int} (1\%)$ is the rms value of half the emf (terminal voltage at matching) of a 100% sine modulated TV carrier at an internal generator resistance of 60 Ω, causing 1% amplitude modulation on the active carrier.

SOT 143

- For high-gain, low-distortion VHF TV and FM mixer and input stages
- Miniature plastic package for surface mounting (SMD)

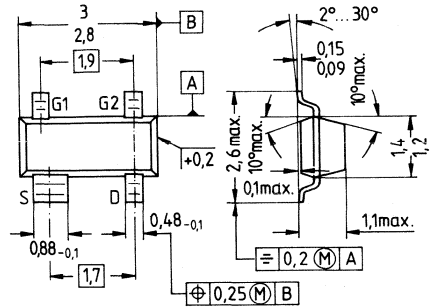

Dimensions in mm

Type	BF 993	
Ordering code	bulk: Q62702-F899	taped: Q62702-F1018
Marking	ME	

Maximum ratings

Drain-source voltage	V_{DS}	20	V
Drain current	I_D	50	mA
Gate 1/gate 2 peak source current	$\pm I_{G1/2SM}$	10	mA
Total power dissipation $T_A \leq 60^\circ\text{C}$	P_{tot}	200	mW
Storage temperature range	T_{stg}	-55... +150	$^\circ\text{C}$
Channel temperature	T_{Ch}	150	$^\circ\text{C}$

Thermal resistance

Junction — ambient	R_{thJA}	≤ 450	$\text{K/W}^{1)}$
--------------------	------------	------------	-------------------

¹⁾ Package mounted on alumina 16.7 mm × 15 mm × 0.7 mm

Characteristics ($T_A = 25^\circ\text{C}$)

DC characteristics		min	typ	max	
Drain-source breakdown voltage $I_D = 10\ \mu\text{A}$, $-V_{G1S} = -V_{G2S} = 4\ \text{V}$	$V_{(BR)DS}$	20	—	—	V
Gate 1 source breakdown voltage $\pm I_{G1S} = 10\ \text{mA}$, $V_{G2S} = V_{DS} = 0$	$\pm V_{(BR)G1SS}$	8,5	—	17	V
Gate 2 source breakdown voltage $\pm I_{G2S} = 10\ \text{mA}$, $V_{G1S} = V_{DS} = 0$	$\pm V_{(BR)G2SS}$	8,5	—	17	V
Gate 1 source leakage current $\pm V_{G1S} = 5\ \text{V}$, $V_{G2S} = V_{DS} = 0$	$\pm I_{G1SS}$	—	—	50	nA
Gate 2 source leakage current $\pm V_{G2S} = 5\ \text{V}$, $V_{G1S} = V_{DS} = 0$	$\pm I_{G2SS}$	—	—	50	nA
Drain current $V_{DS} = 15\ \text{V}$, $V_{G1S} = 0$, $V_{G2S} = 4\ \text{V}$	I_{DSS}	6	—	40	mA
Gate 1 source pinch-off voltage $V_{DS} = 15\ \text{V}$, $V_{G2S} = 4\ \text{V}$, $I_D = 20\ \mu\text{A}$	$-V_{G1S(p)}$	—	—	3,5	V
Gate 2 source pinch-off voltage $V_{DS} = 15\ \text{V}$, $V_{G1S} = 0$, $I_D = 20\ \mu\text{A}$	$-V_{G2S(p)}$	—	—	3,0	V

Characteristics ($T_A = 25^\circ\text{C}$)

AC characteristics		min	typ	max	
Forward transconductance $V_{DS} = 15\text{ V}$, $I_D = 10\text{ mA}$, $V_{G2S} = 4\text{ V}$, $f = 1\text{ kHz}$	g_{fs}	16	25	—	mS
Gate 1 input capacitance $V_{DS} = 15\text{ V}$, $I_D = 10\text{ mA}$, $V_{G2S} = 4\text{ V}$, $f = 1\text{ MHz}$	C_{g1ss}	—	6	—	pF
Gate 2 input capacitance $V_{DS} = 15\text{ V}$, $I_D = 10\text{ mA}$, $V_{G2S} = 4\text{ V}$, $f = 1\text{ MHz}$	C_{g2ss}	—	2,5	—	pF
Feedback capacitance $V_{DS} = 15\text{ V}$, $I_D = 10\text{ mA}$, $V_{G2S} = 4\text{ V}$, $f = 1\text{ MHz}$	C_{dg1}	—	50	—	fF
Output capacitance $V_{DS} = 15\text{ V}$, $I_D = 10\text{ mA}$, $V_{G2S} = 4\text{ V}$, $f = 1\text{ MHz}$	C_{dss}	—	2,5	—	pF
Power gain $V_{DS} = 15\text{ V}$, $I_D = 10\text{ mA}$ $f = 200\text{ MHz}$, $G_G = 2\text{ mS}$, $G_L = 0,5\text{ mS}$ $2\Delta f = 12\text{ MHz}$ (test circuit)	G_{ps}	—	25	—	dB
Noise figure $V_{DS} = 15\text{ V}$, $I_D = 10\text{ mA}$ $f = 200\text{ MHz}$, $G_G = 2\text{ mS}$, $G_L = 0,5\text{ mS}$ (test circuit)	F	—	1,5	—	dB

Total power dissipation $P_{tot} = f(T_A)$

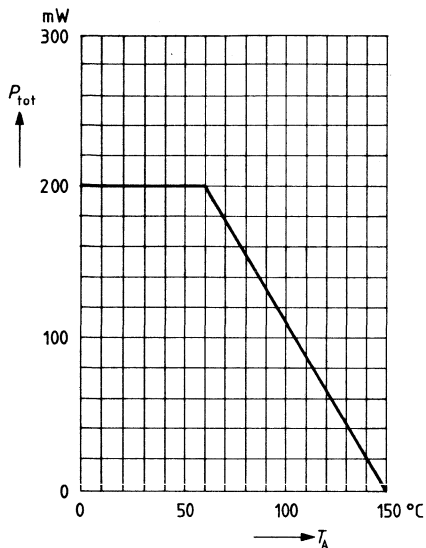

Output characteristics $I_D = f(V_{DS})$

$V_{G2S} = 4\text{ V}$

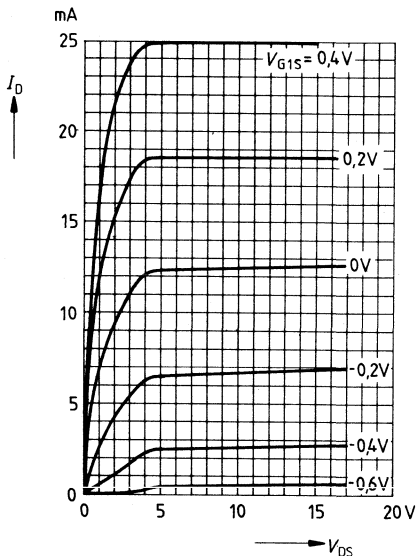

Gate 1 forward transconductance

$g_{fs1} = f(V_{G1S})$

$V_{DS} = 15\text{ V}$, $I_{DSS} = 10\text{ mA}$, $f = 1\text{ kHz}$

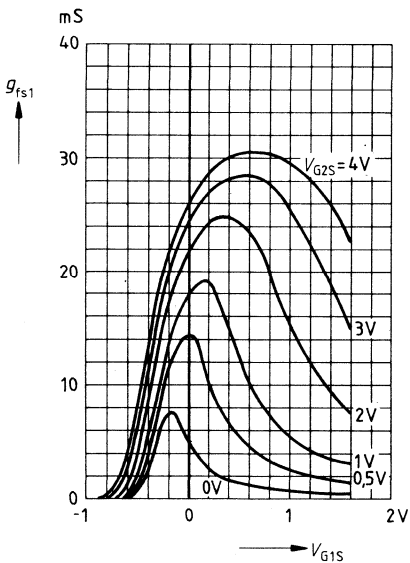

Gate 1 forward transconductance

$g_{fs1} = f(V_{G2S})$

$V_{DS} = 15\text{ V}$, $I_{DSS} = 10\text{ mA}$, $f = 1\text{ kHz}$

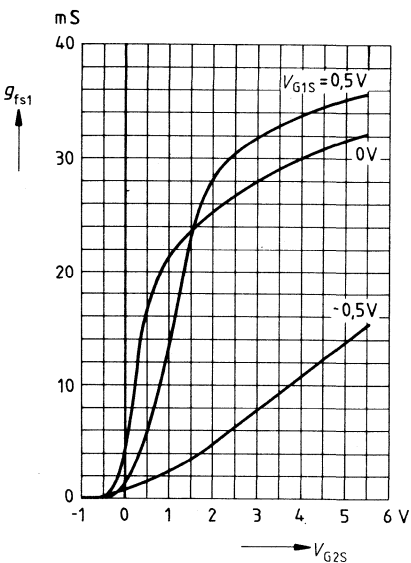

Drain current $I_D = f(V_{G1S})$

$V_{DS} = 15 \text{ V}$

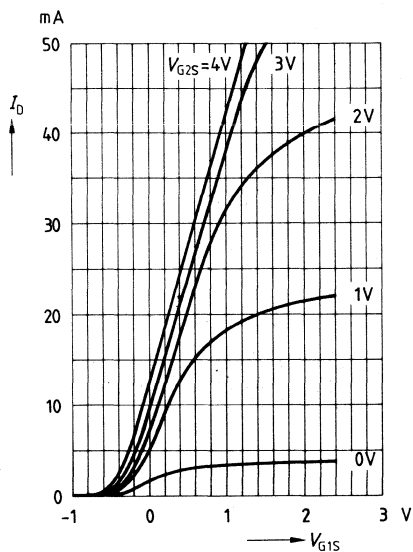

Gate 1 input capacitance $c_{g1ss} = f(V_{G1S})$

$V_{G2S} = 4 \text{ V}, V_{DS} = 15 \text{ V}$

$I_{DSS} = 10 \text{ mA}, f = 1 \text{ MHz}$

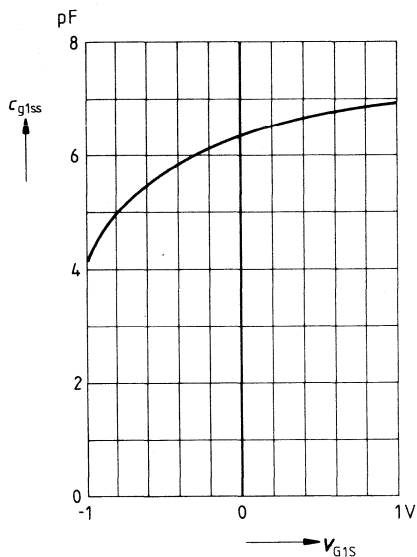

Gate 2 input capacitance $c_{g2ss} = f(V_{G2S})$

$V_{G1S} = 0 \text{ V}, V_{DS} = 15 \text{ V}$

$I_{DSS} = 10 \text{ mA}, f = 1 \text{ MHz}$

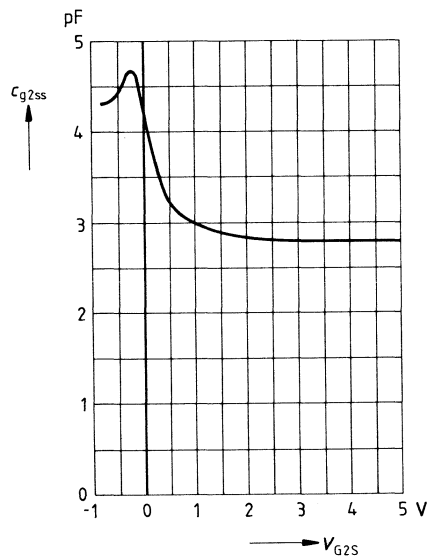

Output capacitance $c_{dss} = f(V_{DS})$

$V_{G1S} = 0 \text{ V}, V_{G2S} = 4 \text{ V}$

$I_{DSS} = 10 \text{ mA}, f = 1 \text{ MHz}$

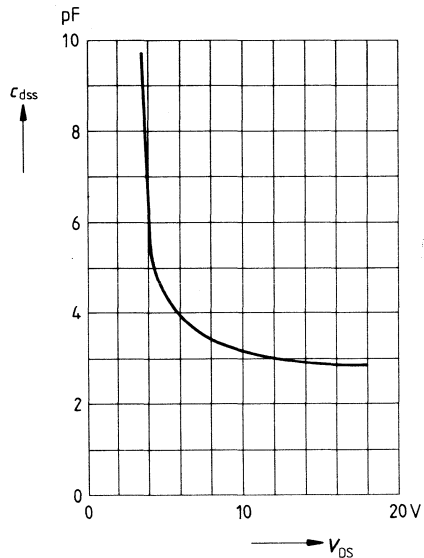

Gate 1 input admittance y_{11s}

$V_{DS} = 15\text{ V}$, $V_{G2S} = 4\text{ V}$
(common source)

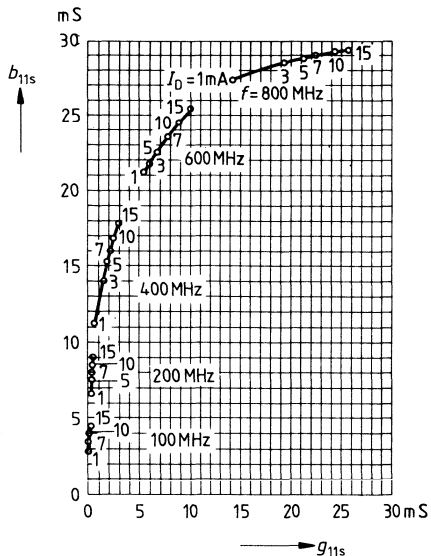

Gate 1 forward transfer admittance y_{21s}

$V_{DS} = 15\text{ V}$, $V_{G2S} = 4\text{ V}$
(common source)

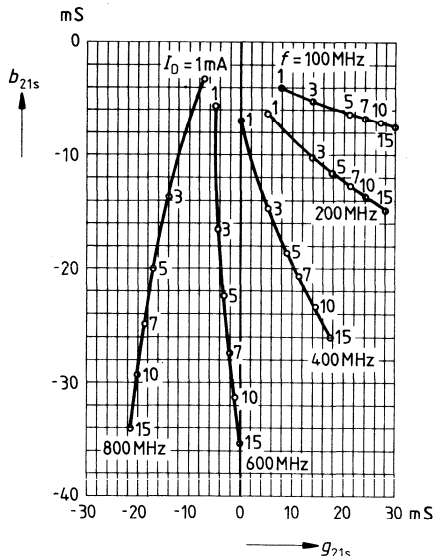

Output admittance y_{22s}

$V_{DS} = 15\text{ V}$, $V_{G2S} = 4\text{ V}$
(common source)

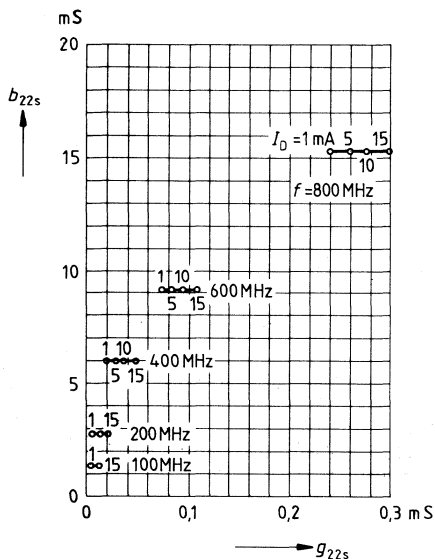

Power gain $G_{ps} = f(V_{G2S})$

$V_{DS} = 15\text{ V}$, $V_{G1S} = 0\text{ V}$, $I_{DSS} = 10\text{ mA}$
 $f = 200\text{ MHz}$ (see test circuit)

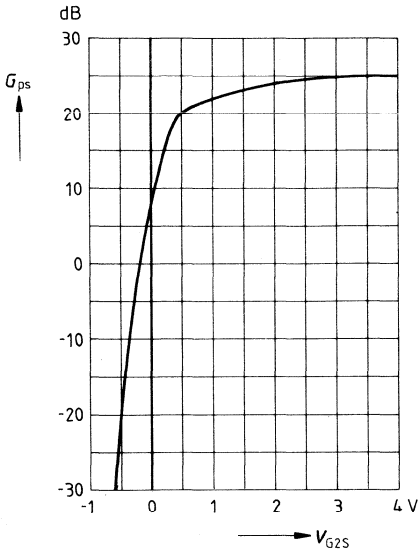

Noise figure $F = f(V_{G2S})$

$V_{DS} = 15\text{ V}$, $V_{G1S} = 0\text{ V}$, $I_{DSS} = 10\text{ mA}$
 $f = 200\text{ MHz}$ (see test circuit)

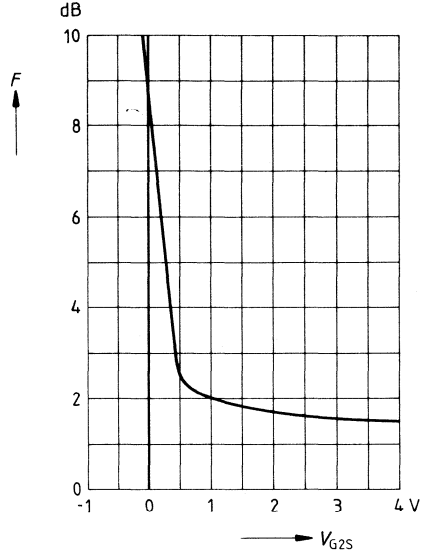

Test circuit for power gain and noise figure

$f = 200\text{ MHz}$, $G_G = 2\text{ mS}$, $G_L = 0,5\text{ mS}$

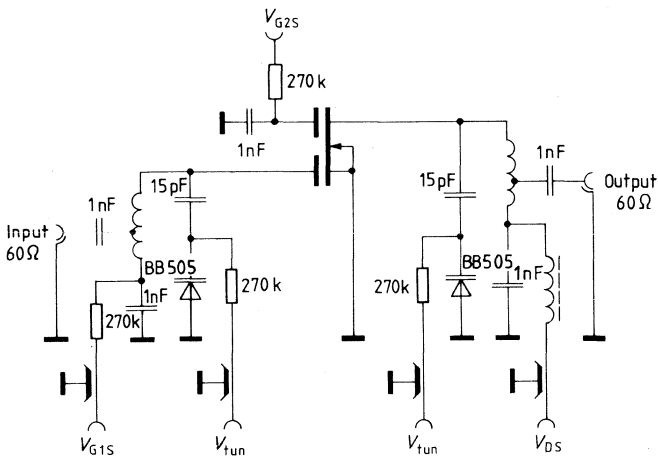

- For VHF applications, especially for input and mixer stages with a wide tuning range, e. g. in CATV tuners
- Miniature plastic package for surface mounting (SMD)

SOT 143

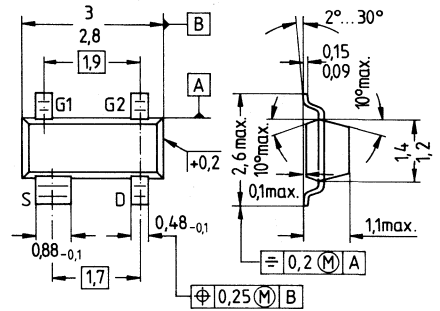

Dimensions in mm

Type	BF 994 S	
Ordering code	bulk: Q62702-F963	taped: Q62702-F1020
Marking	MG	

Maximum ratings

Drain-source voltage	V_{DS}	20	V
Drain current	I_D	30	mA
Gate 1/gate 2 peak source current	$\pm I_{G1/2SM}$	10	mA
Total power dissipation	P_{tot}	200	mW
$T_A \leq 60^\circ C$			
Storage temperature range	T_{stg}	- 55... + 150	$^\circ C$
Channel temperature	T_{Ch}	150	$^\circ C$

Thermal resistance

Junction — ambient	R_{thJA}	≤ 450	$ K/W^1)$
--------------------	------------	------------	------------

¹⁾ Package mounted on alumina 16.7 mm × 15 mm × 0.7 mm

Characteristics ($T_A = 25^\circ\text{C}$)

DC characteristics

		min	typ	max	
Drain-source breakdown voltage $I_D = 10\ \mu\text{A}$, $-V_{G1S} = -V_{G2S} = 4\ \text{V}$	$V_{(BR)DS}$	20	—	—	V
Gate 1 source breakdown voltage $\pm I_{G1S} = 10\ \text{mA}$, $V_{G2S} = V_{DS} = 0$	$\pm V_{(BR)G1SS}$	8,5	—	17	V
Gate 2 source breakdown voltage $\pm I_{G2S} = 10\ \text{mA}$, $V_{G1S} = V_{DS} = 0$	$\pm V_{(BR)G2SS}$	8,5	—	17	V
Gate 1 source leakage current $\pm V_{G1S} = 5\ \text{V}$, $V_{G2S} = V_{DS} = 0$	$\pm I_{G1SS}$	—	—	50	nA
Gate 2 source leakage current $\pm V_{G2S} = 5\ \text{V}$, $V_{G1S} = V_{DS} = 0$	$\pm I_{G2SS}$	—	—	50	nA
Drain current $V_{DS} = 15\ \text{V}$, $V_{G1S} = 0$, $V_{G2S} = 4\ \text{V}$	I_{DSS}	2	—	20	mA
Gate 1 source pinch-off voltage $V_{DS} = 15\ \text{V}$, $V_{G2S} = 4\ \text{V}$, $I_D = 20\ \mu\text{A}$	$-V_{G1S(p)}$	—	—	2,5	V
Gate 2 source pinch-off voltage $V_{DS} = 15\ \text{V}$, $V_{G1S} = 0$, $I_D = 20\ \mu\text{A}$	$-V_{G2S(p)}$	—	—	2,0	V

AC characteristics

Forward transconductance $V_{DS} = 15\ \text{V}$, $I_D = 10\ \text{mA}$, $V_{G2S} = 4\ \text{V}$, $f = 1\ \text{kHz}$	g_{fs}	15	18	—	mS
Gate 1 input capacitance $V_{DS} = 15\ \text{V}$, $I_D = 10\ \text{mA}$, $V_{G2S} = 4\ \text{V}$, $f = 1\ \text{MHz}$	C_{g1ss}	—	2,5	—	pF
Gate 2 input capacitance $V_{DS} = 15\ \text{V}$, $I_D = 10\ \text{mA}$, $V_{G2S} = 4\ \text{V}$, $f = 1\ \text{MHz}$	C_{g2ss}	—	1,2	—	pF
Feedback capacitance $V_{DS} = 15\ \text{V}$, $I_D = 10\ \text{mA}$, $V_{G2S} = 4\ \text{V}$, $f = 1\ \text{MHz}$	C_{dg1}	—	25	—	fF
Output capacitance $V_{DS} = 15\ \text{V}$, $I_D = 10\ \text{mA}$, $V_{G2S} = 4\ \text{V}$, $f = 1\ \text{MHz}$	C_{dss}	—	1	—	pF
Power gain $V_{DS} = 15\ \text{V}$, $I_D = 10\ \text{mA}$ $f = 200\ \text{MHz}$, $G_G = 2\ \text{mS}$, $G_L = 0,5\ \text{mS}$ (test circuit)	G_{ps}	—	25	—	dB
Noise figure $V_{DS} = 15\ \text{V}$, $I_D = 10\ \text{mA}$ $f = 200\ \text{MHz}$, $G_G = 2\ \text{mS}$, $G_L = 0,5\ \text{mS}$ (test circuit)	F	—	1	—	dB
Gain control range $V_{DS} = 15\ \text{V}$, $V_{G2S} = 4 \dots -2\ \text{V}$, $f = 200\ \text{MHz}$ (test circuit)	ΔG_{ps}	50	—	—	dB

Total power dissipation $P_{tot} = f(T_A)$

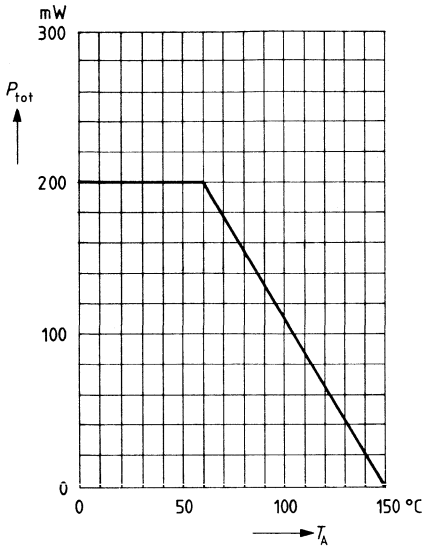

Output characteristics $I_D = f(V_{DS})$

$V_{G2S} = 4\text{ V}$

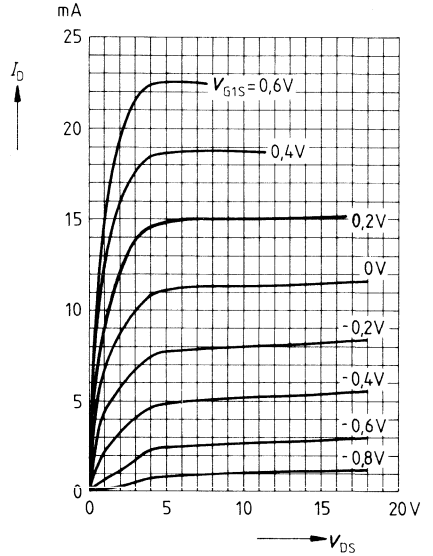

Gate 1 forward transconductance

$g_{fs1} = f(V_{G1S})$

$V_{DS} = 15\text{ V}$

$I_{DSS} = 10\text{ mA}, f = 1\text{ kHz}$

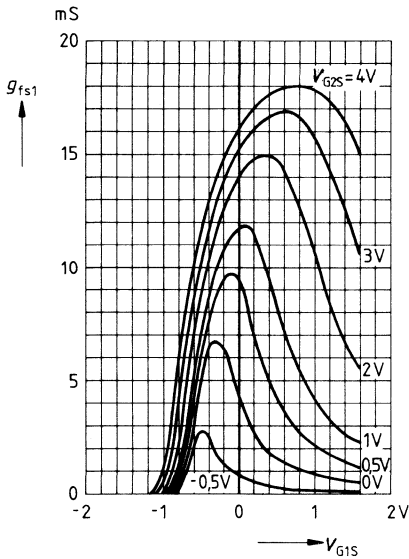

Gate 1 forward transconductance

$g_{fs1} = f(V_{G2S})$

$V_{DS} = 15\text{ V}$

$I_{DSS} = 10\text{ mA}, f = 1\text{ kHz}$

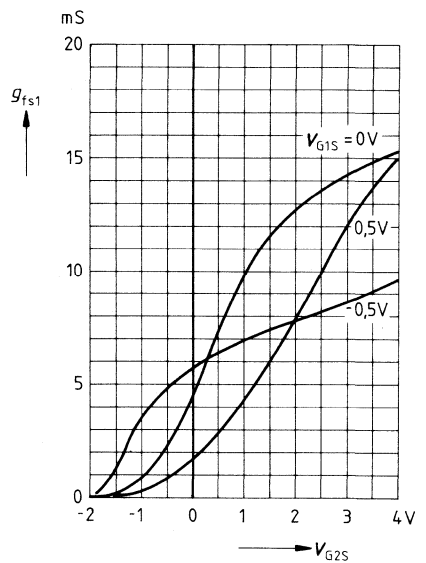

Drain current $I_D = f(V_{G1S})$

$V_{DS} = 15 \text{ V}$

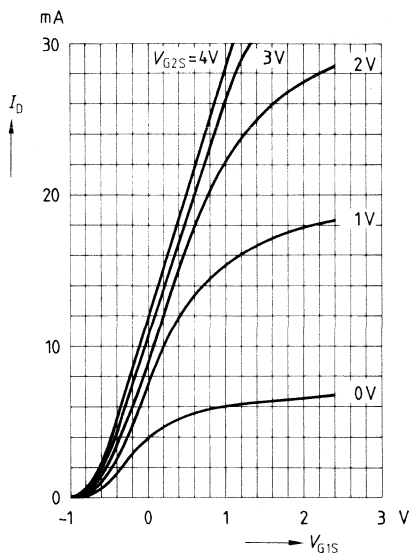

Gate 1 input capacitance $c_{g1ss} = f(V_{G1S})$

$V_{G2S} = 4 \text{ V}, V_{DS} = 15 \text{ V}$

$I_{DSS} = 10 \text{ mA}, f = 1 \text{ MHz}$

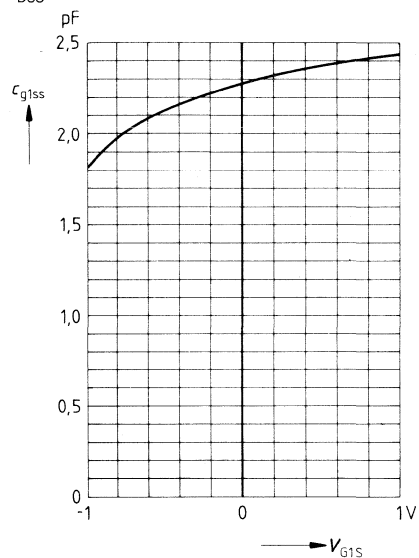

Gate 2 input capacitance $c_{g2ss} = f(V_{G2S})$

$V_{G1S} = 0 \text{ V}, V_{DS} = 15 \text{ V}$

$I_{DSS} = 10 \text{ mA}, f = 1 \text{ MHz}$

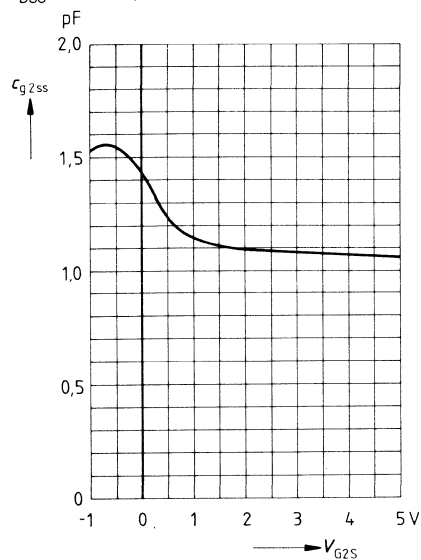

Output capacitance $c_{dss} = f(V_{DS})$

$V_{G1S} = 0 \text{ V}, V_{G2S} = 4 \text{ V}$

$I_{DSS} = 10 \text{ mA}, f = 1 \text{ MHz}$

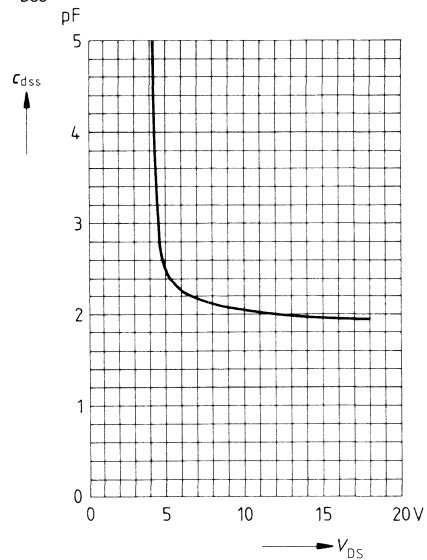

Gate 1 input admittance y_{11s}

$V_{DS} = 15\text{ V}$; $V_{GS2S} = 4\text{ V}$
(common source)

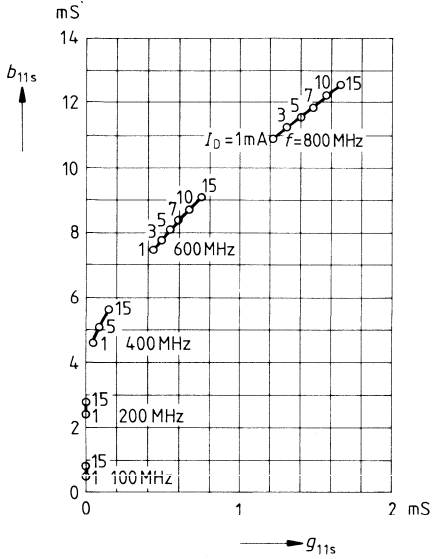

Gate 1 forward transfer admittance y_{21s}

$V_{DS} = 15\text{ V}$, $V_{GS2S} = 4\text{ V}$
(common source)

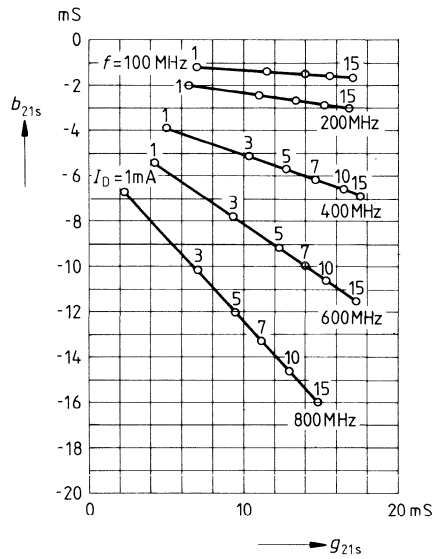

Output admittance y_{22s}

$V_{DS} = 15\text{ V}$, $V_{GS2S} = 4\text{ V}$
(common source)

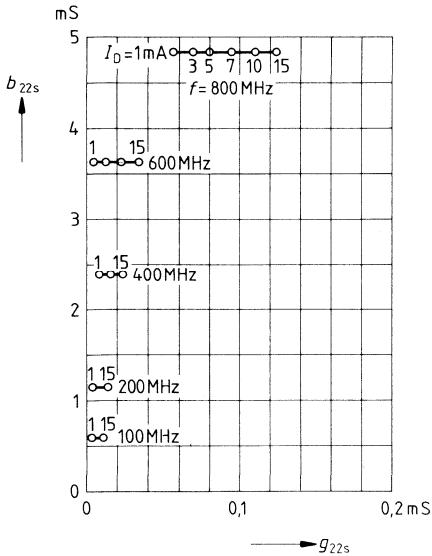

Power gain $G_{ps} = f(V_{G2S})$

$V_{DS} = 15\text{ V}$, $V_{G1S} = 0\text{ V}$

$I_{DSS} = 10\text{ mA}$, $f = 200\text{ MHz}$
(see test circuit)

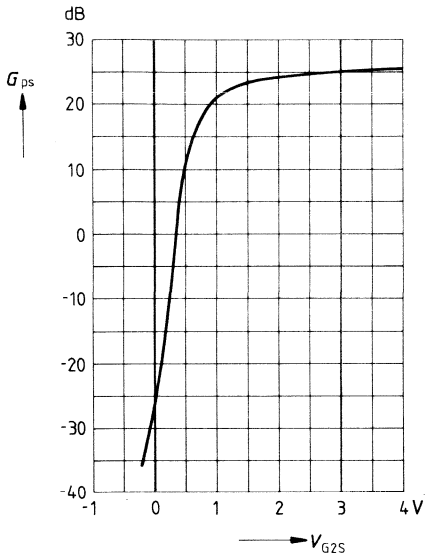

Noise figure $F = f(V_{G2S})$

$V_{DS} = 15\text{ V}$, $V_{G1S} = 0\text{ V}$

$I_{DSS} = 10\text{ mA}$, $f = 200\text{ MHz}$
(see test circuit)

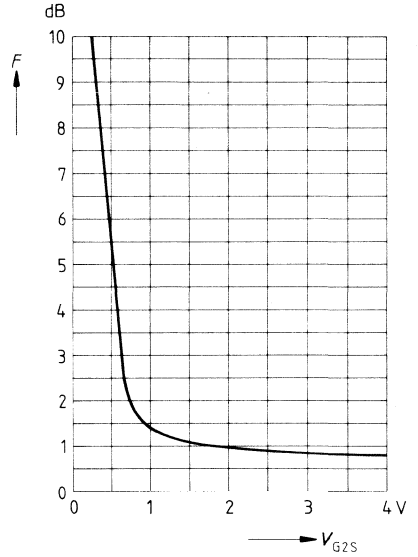

Test circuit for power gain and noise figure

$f = 200\text{ MHz}$, $G_G = 2\text{ mS}$, $G_L = 0,5\text{ mS}$

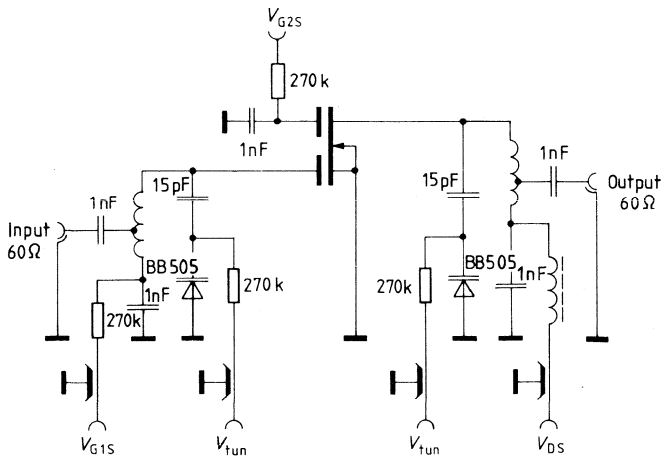

- For input and mixer stages in FM and VHF TV tuners
- Miniature plastic package for surface mounting (SMD)

SOT 143

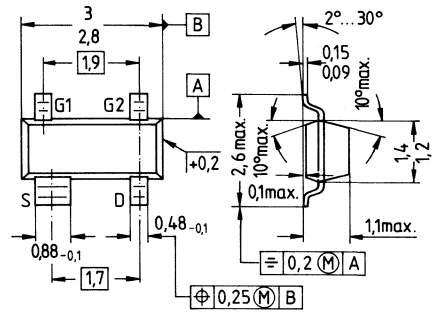

Dimensions in mm

Type	BF 995	
Ordering code	bulk: Q62702-F872	taped: Q62702-F936
Marking	MB	

Maximum ratings

Drain-source voltage	V_{DS}	20	V
Drain current	I_D	30	mA
Gate 1/gate 2 peak source current	$\pm I_{G1/2SM}$	10	mA
Total power dissipation $T_A \leq 60^\circ C$	P_{tot}	200	mW
Storage temperature range	T_{stg}	- 55... + 150	$^\circ C$
Channel temperature	T_{Ch}	150	$^\circ C$

Thermal resistance

Junction — ambient	R_{thJA}	≤ 450	$K/W^{(1)}$
--------------------	------------	------------	-------------

¹⁾ Package mounted on alumina 16.7 mm × 15 mm × 0.7 mm

Characteristics ($T_A = 25^\circ\text{C}$)

DC characteristics

		min	typ	max	
Drain-source breakdown voltage $I_D = 10\ \mu\text{A}$, $-V_{G1S} = -V_{G2S} = 4\ \text{V}$	$V_{(BR)DS}$	20	—	—	V
Gate 1 source breakdown voltage $\pm I_{G1S} = 10\ \text{mA}$, $V_{G2S} = V_{DS} = 0$	$\pm V_{(BR)G1SS}$	8,5	—	17	V
Gate 2 source breakdown voltage $\pm I_{G2S} = 10\ \text{mA}$, $V_{G1S} = V_{DS} = 0$	$\pm V_{(BR)G2SS}$	8,5	—	17	V
Gate 1 source leakage current $\pm V_{G1S} = 5\ \text{V}$, $V_{G2S} = V_{DS} = 0$	$\pm I_{G1SS}$	—	—	50	nA
Gate 2 source leakage current $\pm V_{G2S} = 5\ \text{V}$, $V_{G1S} = V_{DS} = 0$	$\pm I_{G2SS}$	—	—	50	nA
Drain current $V_{DS} = 15\ \text{V}$, $V_{G1S} = 0$, $V_{G2S} = 4\ \text{V}$	I_{DSS}	4	—	20	mA
Gate 1 source pinch-off voltage $V_{DS} = 15\ \text{V}$, $V_{G2S} = 4\ \text{V}$, $I_D = 20\ \mu\text{A}$	$-V_{G1S(p)}$	—	—	3,5	V
Gate 2 source pinch-off voltage $V_{DS} = 15\ \text{V}$, $V_{G1S} = 0$, $I_D = 20\ \mu\text{A}$	$-V_{G2S(p)}$	—	—	3,5	V

Characteristics ($T_A = 25^\circ\text{C}$)

AC characteristics		min	typ	max	
Forward transconductance $V_{DS} = 15\text{ V}, I_D = 10\text{ mA}, V_{G2S} = 4\text{ V}, f = 1\text{ kHz}$	g_{fs}	12	17	—	mS
Gate 1 input capacitance $V_{DS} = 15\text{ V}, I_D = 10\text{ mA}, V_{G2S} = 4\text{ V}, f = 1\text{ MHz}$	C_{g1ss}	—	3,6	—	pF
Gate 2 input capacitance $V_{DS} = 15\text{ V}, I_D = 10\text{ mA}, V_{G2S} = 4\text{ V}, f = 1\text{ MHz}$	C_{g2ss}	—	1,6	—	pF
Feedback capacitance $V_{DS} = 15\text{ V}, I_D = 10\text{ mA}, V_{G2S} = 4\text{ V}, f = 1\text{ MHz}$	C_{dg1}	—	25	—	fF
Output capacitance $V_{DS} = 15\text{ V}, I_D = 10\text{ mA}, V_{G2S} = 4\text{ V}, f = 1\text{ MHz}$	C_{dss}	—	1,6	—	pF
Power gain $V_{DS} = 15\text{ V}, I_D = 10\text{ mA}$ $f = 200\text{ MHz}, G_G = 2\text{ mS}, G_L = 0,5\text{ mS}$ $2\Delta f = 12\text{ MHz}$ (see test circuit 1)	G_{ps}	—	23	—	dB
Noise figure $V_{DS} = 15\text{ V}, I_D = 10\text{ mA}$ $f = 200\text{ MHz}, G_G = 2\text{ mS}, G_L = 0,5\text{ mS}$ (see test circuit 1)	F	—	1,1	—	dB
Gain control range $V_{DS} = 15\text{ V}, V_{G2S} = 4 \dots -2\text{ V}, f = 200\text{ MHz}$ (see test circuit 1)	ΔG_{ps}	—	50	—	dB
Mixer gain (additive) $V_{DS} = 15\text{ V}, V_{G2S} = 6\text{ V}, R_S = 220\ \Omega$ $f = 200\text{ MHz}, f_{IF} = 36\text{ MHz}$ $2\Delta f_{IF} = 5\text{ MHz}, V_{osc} = 0,5\text{ V}$ (see test circuit 2)	G_{psc}	—	16	—	dB
Mixer gain (multiplicative) $V_{DS} = 15\text{ V}, V_{G1S} = 1,7\text{ V}, V_{G2S} = 2,5\text{ V}$ $R_S = 220\ \Omega, f = 200\text{ MHz}, f_{IF} = 36\text{ MHz}$ $2\Delta f_{IF} = 5\text{ MHz}, V_{osc} = 2\text{ V}$ (see test circuit 3)	G_{psc}	—	18	—	dB

Total power dissipation $P_{tot} = f(T_A)$

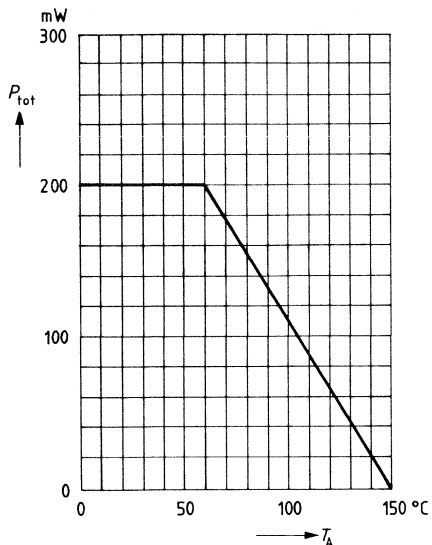

Output characteristics $I_D = f(V_{DS})$

$V_{G2S} = 4\text{ V}$

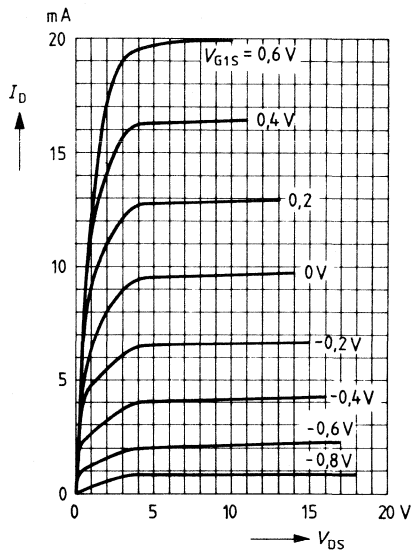

Gate 1 forward transconductance

$g_{fs1} = f(V_{G1S})$

$V_{DS} = 15\text{ V}, I_{DSS} = 10\text{ mA}, f = 1\text{ kHz}$

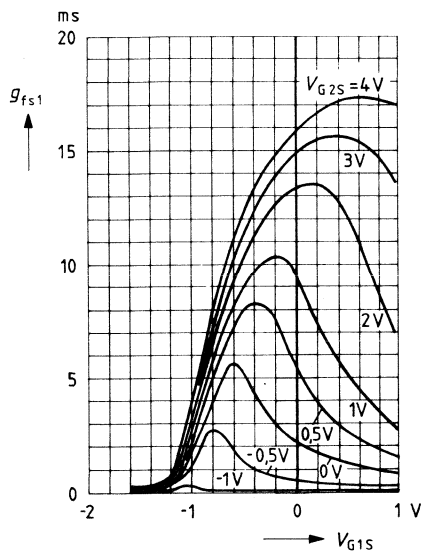

Gate 1 forward transconductance

$g_{fs1} = f(V_{G2S})$

$V_{DS} = 15\text{ V}, I_{DSS} = 10\text{ mA}, f = 1\text{ kHz}$

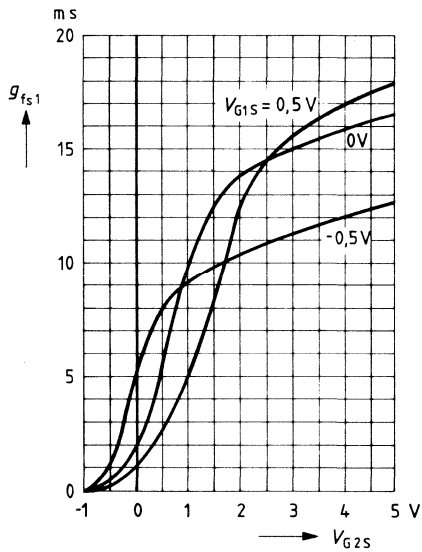

Drain current $I_D = f(V_{G1S})$

$V_{DS} = 15\text{ V}$

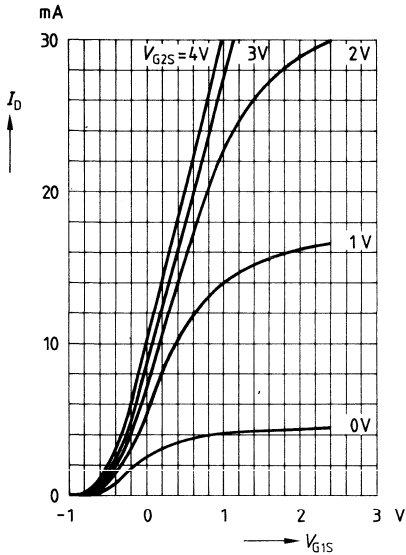

Gate 1 input capacitance $c_{g1ss} = f(V_{G1S})$

$V_{G2S} = 4\text{ V}, V_{DS} = 15\text{ V}$

$I_{DSS} = 10\text{ mA}, f = 1\text{ MHz}$

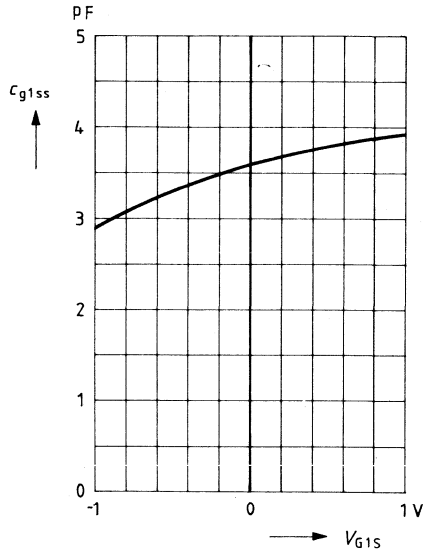

Gate 2 input capacitance $c_{g2ss} = f(V_{G2S})$

$V_{G1S} = 0\text{ V}, V_{DS} = 15\text{ V}$

$I_{DSS} = 10\text{ mA}, f = 1\text{ MHz}$

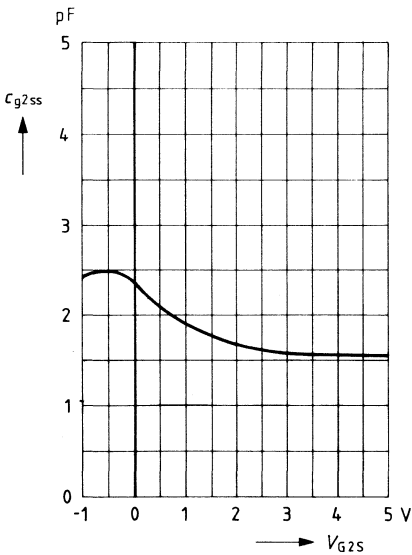

Output capacitance $c_{dss} = f(V_{DS})$

$V_{G1S} = 0\text{ V}, V_{G2S} = 4\text{ V}$

$I_{DSS} = 10\text{ mA}, f = 1\text{ MHz}$

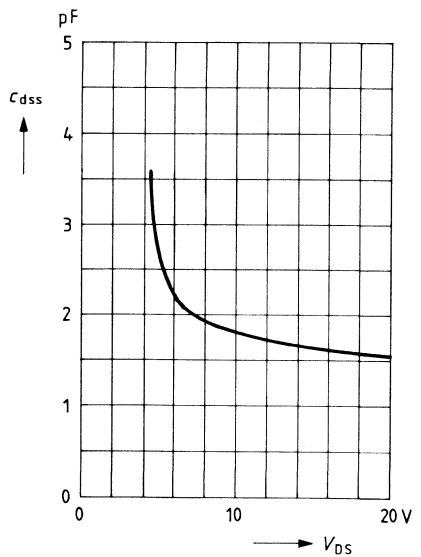

Gate 1 input admittance y_{11s}

$V_{DS} = 15\text{ V}$, $V_{G2S} = 4\text{ V}$
(common source)

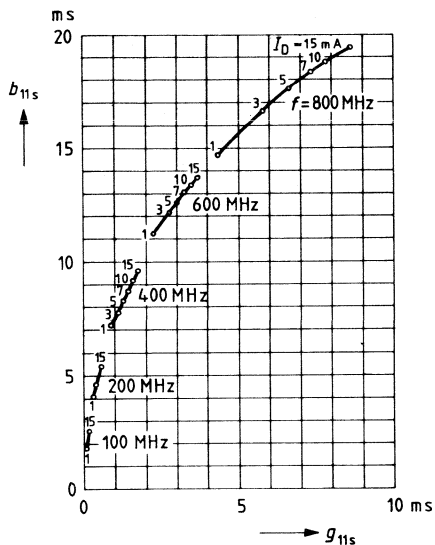

Gate 1 forward transfer admittance y_{21s}

$V_{DS} = 15\text{ V}$, $V_{G2S} = 4\text{ V}$
(common source)

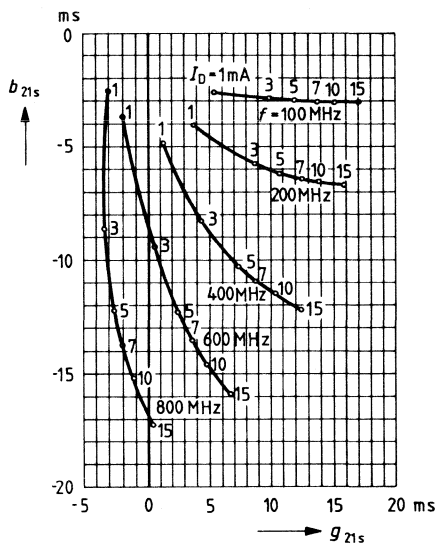

Output admittance y_{22s}

$V_{DS} = 15\text{ V}$, $V_{G2S} = 4\text{ V}$
(common source)

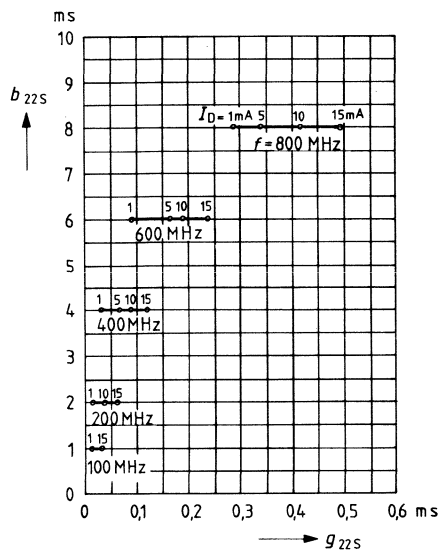

Power gain $G_{ps} = f(V_{G2S})$

$V_{DS} = 15\text{ V}$, $V_{G1S} = 0\text{ V}$, $I_{DSS} = 10\text{ mA}$
 $f = 200\text{ MHz}$ (see test circuit 1)

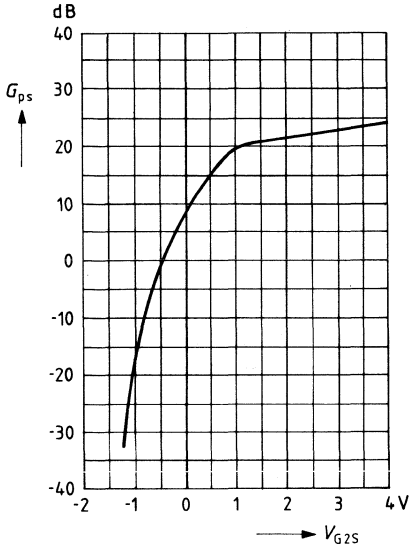

Noise figure $F = f(V_{G2S})$

$V_{DS} = 15\text{ V}$, $V_{G1S} = 0\text{ V}$, $I_{DSS} = 10\text{ mA}$
 $f = 200\text{ MHz}$ (see test circuit 1)

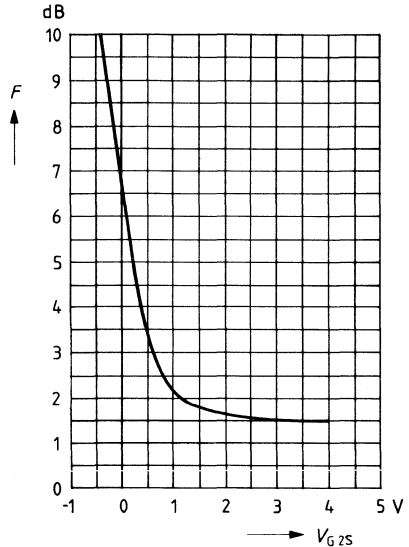

Interference voltage for 1% cross modulation

$V_{int(1\%)} = f(\Delta G_{ps})^{11}$

$V_{DS} = 15\text{ V}$, $V_{G1S} = 0$, $f = 200\text{ MHz}$
 $f_{int} = 221\text{ MHz}$ (see test circuit 1)

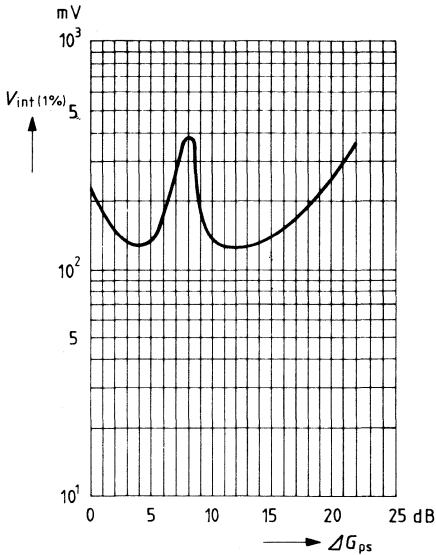

Interference voltage for 1% cross modulation

$V_{int(1\%)} = f(f_{int})^{11}$

$V_{DS} = 15\text{ V}$, $V_{G2S} = 4\text{ V}$, $V_{G1S} = 0$
 $f = 200\text{ MHz}$ (see test circuit 1)

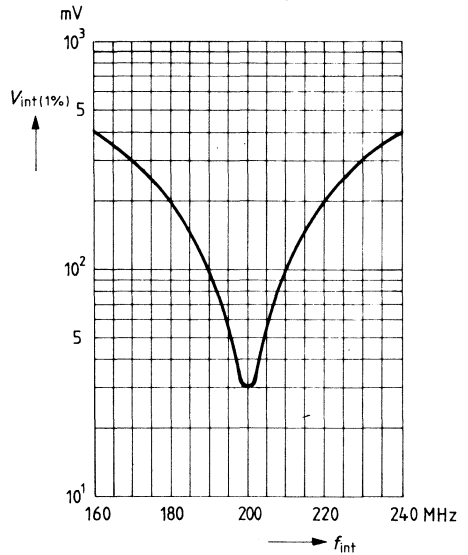

1) Footnote see page 223

Mixer gain (additive) $G_{psc} = f(V_{osc})$

$V_D = 15\text{ V}$, $V_{G1S} = 0$, $V_{G2S} = 6\text{ V}$
 $R_S = 220\ \Omega$, $I_{DSS} = 10\text{ mA}$, $f = 200\text{ MHz}$
 $f_{IF} = 36\text{ MHz}$ (see test circuit 2)

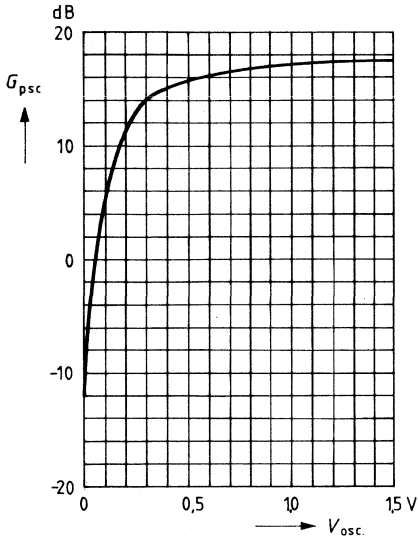

Mixer gain (additive) $G_{psc} = f(V_{G2S})$

$V_D = 15\text{ V}$, $V_{G1S} = 0$, $R_S = 220\ \Omega$
 $V_{osc} = 0,5\text{ V}$, $I_{DSS} = 10\text{ mA}$, $f = 200\text{ MHz}$
 $f_{IF} = 36\text{ MHz}$ (see test circuit 2)

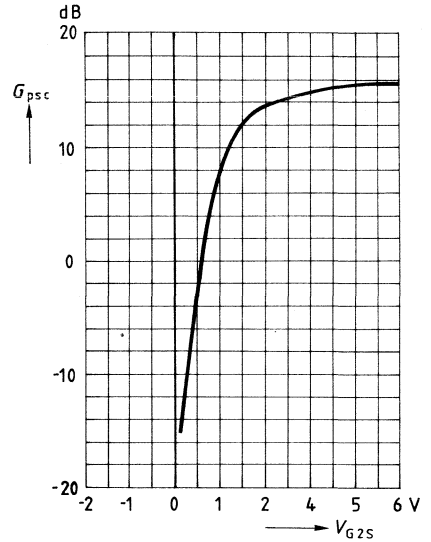

Mixer gain (additive) $G_{psc} = f(R_S)$

$V_D = 15\text{ V}$, $V_{G1S} = 0$, $V_{G2S} = 6\text{ V}$
 $V_{osc} = 0,5\text{ V}$, $f = 200\text{ MHz}$
 $f_{IF} = 36\text{ MHz}$ (see test circuit 2)

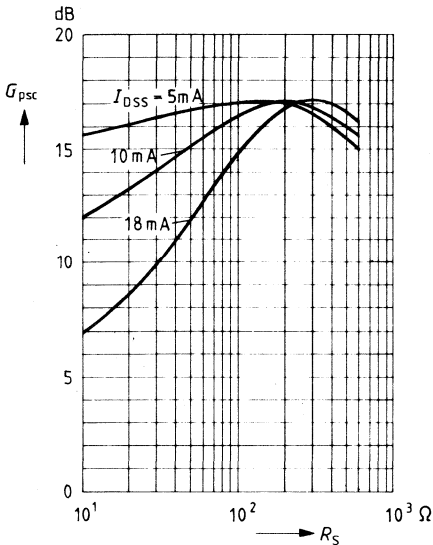

Mixer gain (multiplicative) $G_{psc} = f(V_{G2S})$

$V_D = 15\text{ V}$, $V_{G1S} = 1,7\text{ V}$, $R_S = 200\ \Omega$
 $I_{DSS} = 10\text{ mA}$, $f = 200\text{ MHz}$
 $f_{IF} = 36\text{ MHz}$ (see test circuit 3)

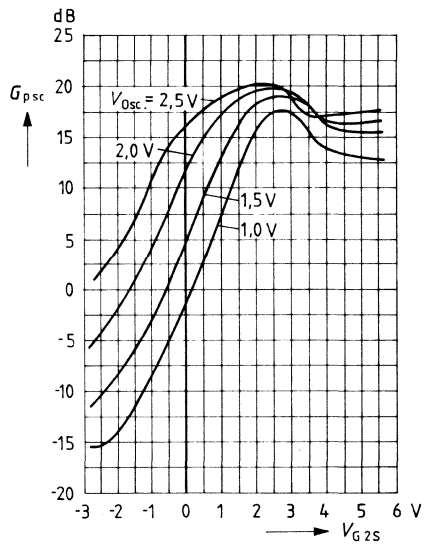

Test circuit 1 for power gain, noise figure and cross modulation

$f = 200 \text{ MHz}$, $G_G = 2 \text{ mS}$, $G_L = 0,5 \text{ mS}$

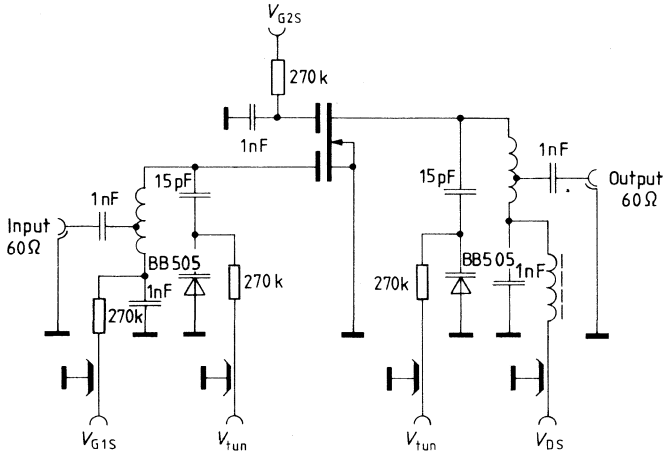

Test circuit 2 for mixer gain (additive)

$f = 200 \text{ MHz}$, $f_{osc} = 236 \text{ MHz}$, $2 \Delta f_{IF} = 5 \text{ MHz}$

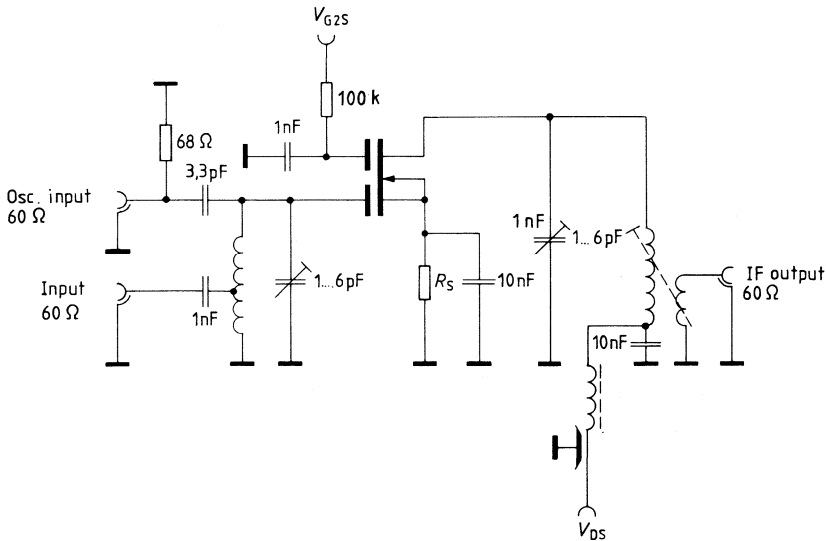

- For input stages in UHF TV tuners
- High transconductance
- Low noise figure
- Miniature plastic package for surface mounting (SMD)

SOT 143

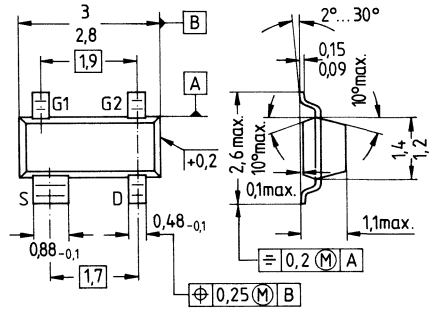

Dimensions in mm

Type	BF 996 S	
Ordering code	bulk: Q62702-F964	taped: Q62702-F1021
Marking	MH	

Maximum ratings

Drain-source voltage	V_{DS}	20	V
Drain current	I_D	30	mA
Gate 1/gate 2 peak source current	$\pm I_{G1/2SM}$	10	mA
Total power dissipation	P_{tot}	200	mW
$T_A \leq 60^\circ\text{C}$			
Storage temperature range	T_{stg}	- 55... + 150	$^\circ\text{C}$
Channel temperature	T_{Ch}	150	$^\circ\text{C}$

Thermal resistance

Junction — ambient	R_{thJA}	≤ 450	K/W ¹⁾
--------------------	------------	------------	-------------------

¹⁾ Package mounted on alumina 16.7 mm × 15 mm × 0.7 mm

Characteristics ($T_A = 25^\circ\text{C}$)

DC characteristics

		min	typ	max	
Drain-source breakdown voltage $I_D = 10\ \mu\text{A}$, $-V_{G1S} = -V_{G2S} = 4\ \text{V}$	$V_{(BR)DS}$	20	—	—	V
Gate 1 source breakdown voltage $\pm I_{G1S} = 10\ \text{mA}$, $V_{G2S} = V_{DS} = 0$	$\pm V_{(BR)G1SS}$	8,5	—	17	V
Gate 2 source breakdown voltage $\pm I_{G2S} = 10\ \text{mA}$, $V_{G1S} = V_{DS} = 0$	$\pm V_{(BR)G2SS}$	8,5	—	17	V
Gate 1 source leakage current $\pm V_{G1S} = 5\ \text{V}$, $V_{G2S} = V_{DS} = 0$	$\pm I_{G1SS}$	—	—	50	nA
Gate 2 source leakage current $\pm V_{G2S} = 5\ \text{V}$, $V_{G1S} = V_{DS} = 0$	$\pm I_{G2SS}$	—	—	50	nA
Drain current $V_{DS} = 15\ \text{V}$, $V_{G1S} = 0$, $V_{G2S} = 4\ \text{V}$	I_{DSS}	2	—	20	mA
Gate 1 source pinch-off voltage $V_{DS} = 15\ \text{V}$, $V_{G2S} = 4\ \text{V}$, $I_D = 20\ \mu\text{A}$	$-V_{G1S(p)}$	—	—	2,5	V
Gate 2 source pinch-off voltage $V_{DS} = 15\ \text{V}$, $V_{G1S} = 0$, $I_D = 20\ \mu\text{A}$	$-V_{G2S(p)}$	—	—	2,0	V

Characteristics ($T_A = 25^\circ\text{C}$)

AC characteristics		min	typ	max	
Forward transconductance $V_{DS} = 15\text{ V}$, $I_D = 10\text{ mA}$, $V_{G2S} = 4\text{ V}$, $f = 1\text{ kHz}$	g_{fs}	15	18	—	mS
Gate 1 input capacitance $V_{DS} = 15\text{ V}$, $I_D = 10\text{ mA}$, $V_{G2S} = 4\text{ V}$, $f = 1\text{ MHz}$	C_{g1ss}	—	2,3	—	pF
Gate 2 input capacitance $V_{DS} = 15\text{ V}$, $I_D = 10\text{ mA}$, $V_{G2S} = 4\text{ V}$, $f = 1\text{ MHz}$	C_{g2ss}	—	1,1	—	pF
Feedback capacitance $V_{DS} = 15\text{ V}$, $I_D = 10\text{ mA}$, $V_{G2S} = 4\text{ V}$, $f = 1\text{ MHz}$	C_{dg1}	—	25	—	fF
Output capacitance $V_{DS} = 15\text{ V}$, $I_D = 10\text{ mA}$, $V_{G2S} = 4\text{ V}$, $f = 1\text{ MHz}$	C_{dss}	—	0,8	—	pF
Power gain $V_{DS} = 15\text{ V}$, $I_D = 10\text{ mA}$ $f = 200\text{ MHz}$, $G_G = 2\text{ mS}$, $G_L = 0,5\text{ mS}$ (test circuit 1)	G_{ps}	—	25	—	dB
$f = 800\text{ MHz}$, $G_G = 2,5\text{ mS}$, $G_L = 0,8\text{ mS}$ (test circuit 2)		—	18	—	dB
Noise figure $V_{DS} = 15\text{ V}$, $I_D = 10\text{ mA}$ $f = 200\text{ MHz}$, $G_G = 2\text{ mS}$, $G_L = 0,5\text{ mS}$ (test circuit 1)	F	—	1	—	dB
$f = 800\text{ MHz}$, $G_G = 2,5\text{ mS}$, $G_L = 0,8\text{ mS}$ (test circuit 2)		—	1,8	—	dB
Gain control range $V_{DS} = 15\text{ V}$, $V_{G2S} = 4\dots -2\text{ V}$, $f = 800\text{ MHz}$ (test circuit 2)	ΔG_{ps}	40	—	—	dB

Total power dissipation $P_{tot} = f(T_A)$

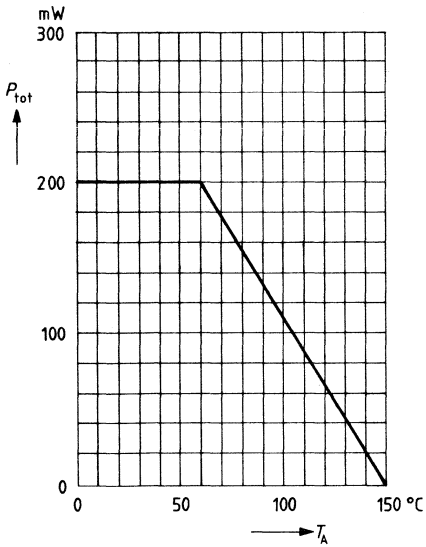

Output characteristics $I_D = f(V_{DS})$

$V_{G2S} = 4V$

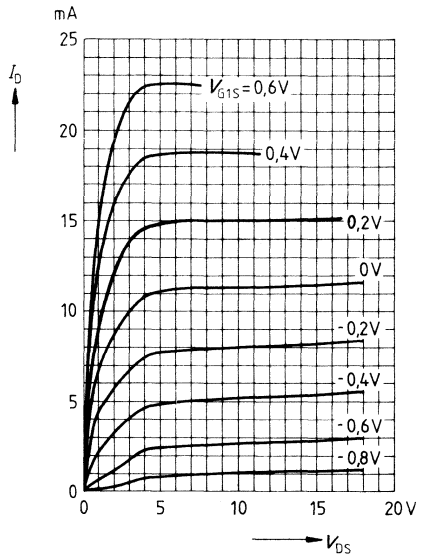

Gate 1 forward transconductance

$g_{fs1} = f(V_{G1S})$

$V_{DS} = 15V, I_{DSS} = 10mA, f = 1kHz$

mS

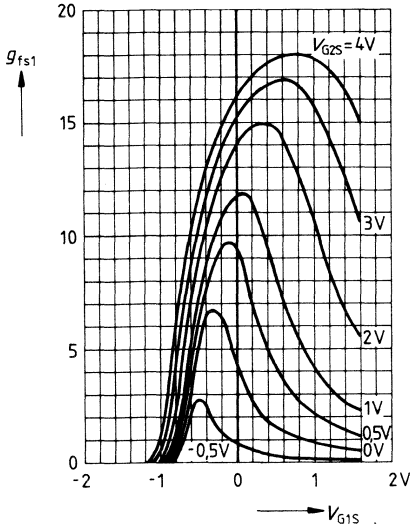

Gate 1 forward transconductance

$g_{fs1} = f(V_{G2S})$

$V_{DS} = 15V, I_{DSS} = 10mA, f = 1kHz$

mS

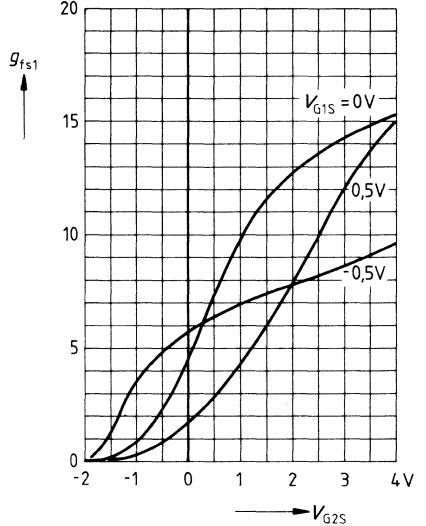

Drain current $I_D = f(V_{G1S})$

$V_{DS} = 15\text{ V}$

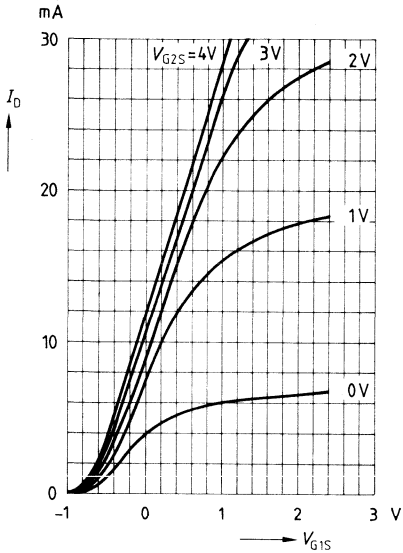

Gate 1 input capacitance $c_{g1ss} = f(V_{G1S})$

$V_{G2S} = 4\text{ V}, V_{DS} = 15\text{ V}$

$I_{DSS} = 10\text{ mA}, f = 1\text{ MHz}$

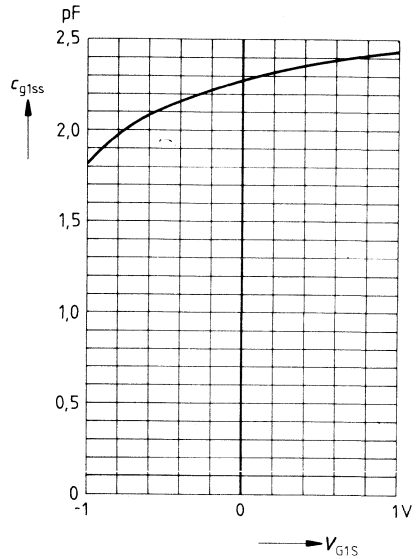

Gate 2 input capacitance $c_{g2ss} = f(V_{G2S})$

$V_{G1S} = 0\text{ V}, V_{DS} = 15\text{ V}$

$I_{DSS} = 10\text{ mA}, f = 1\text{ MHz}$

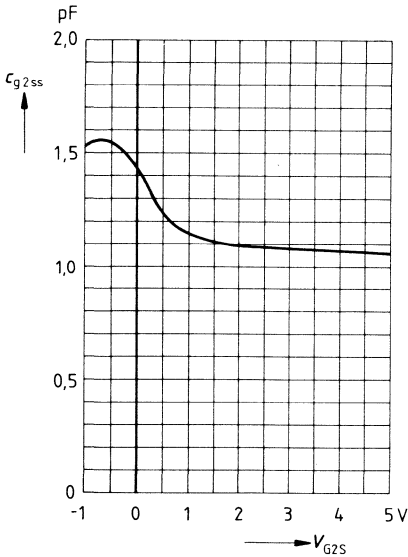

Output capacitance $c_{dss} = f(V_{DS})$

$V_{G1S} = 0\text{ V}, V_{G2S} = 4\text{ V}$

$I_{DSS} = 10\text{ mA}, f = 1\text{ MHz}$

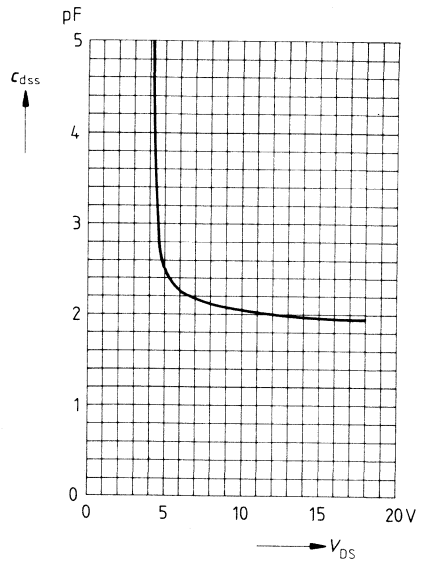

Power gain $G_{ps} = f(V_{G2S})$

$V_{DS} = 15\text{ V}$, $V_{G1S} = 0$, $I_{DSS} = 10\text{ mA}$
 $f = 200\text{ MHz}$ (see test circuit 1)

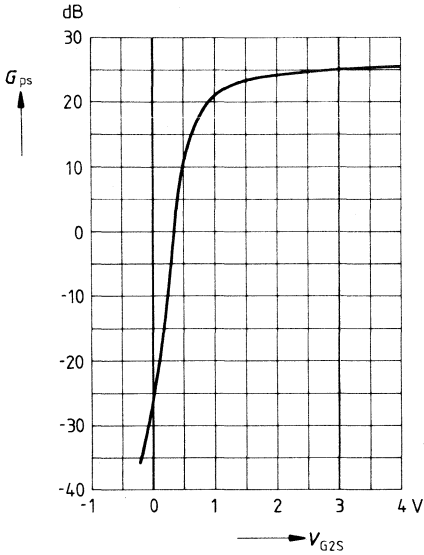

Noise figure $F = f(V_{G2S})$

$V_{DS} = 15\text{ V}$, $V_{G1S} = 0\text{ V}$, $I_{DSS} = 10\text{ mA}$
 $f = 200\text{ MHz}$ (see test circuit 1)

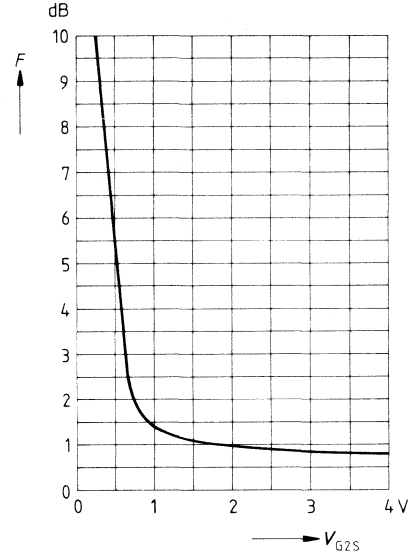

Power gain $G_{ps} = f(V_{G2S})$

$V_{DS} = 15\text{ V}$, $V_{G1S} = 0$, $I_{DSS} = 10\text{ mA}$
 $f = 800\text{ MHz}$ (see test circuit 2)

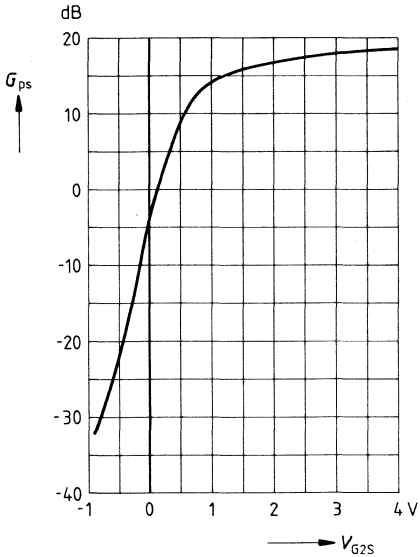

Noise figure $F = f(V_{G2S})$

$V_{DS} = 15\text{ V}$, $V_{G1S} = 0\text{ V}$, $I_{DSS} = 10\text{ mA}$
 $f = 800\text{ MHz}$ (see test circuit 2)

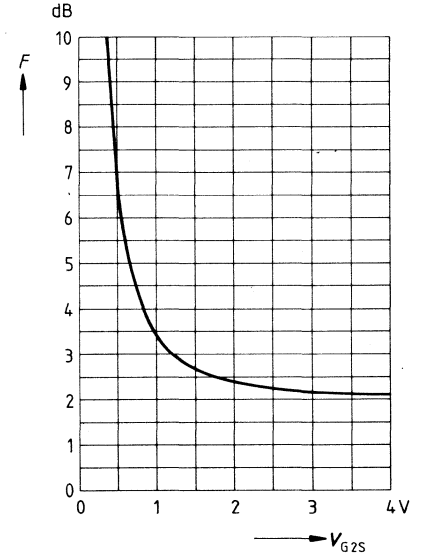

Gate 1 input admittance y_{11s}

$V_{DS} = 15 \text{ V}$, $V_{G2S} = 4 \text{ V}$
(common source)

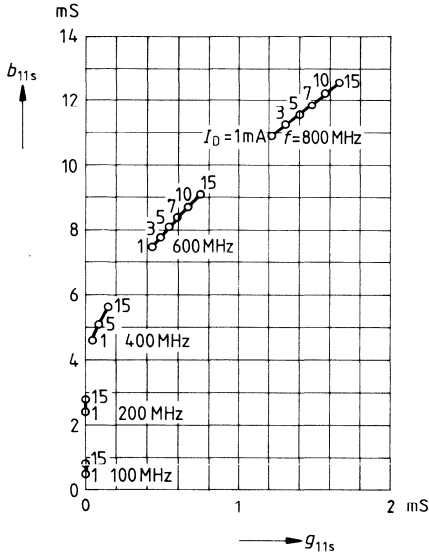

Gate 1 forward transfer admittance y_{21s}

$V_{DS} = 15 \text{ V}$, $V_{G2S} = 4 \text{ V}$
(common source)

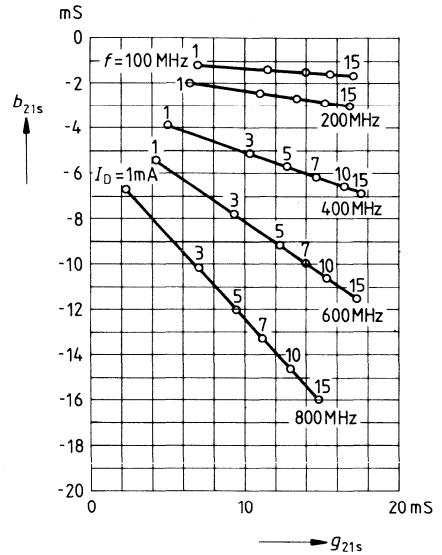

Output admittance y_{22s}

$V_{DS} = 15 \text{ V}$, $V_{G2S} = 4 \text{ V}$
(common source)

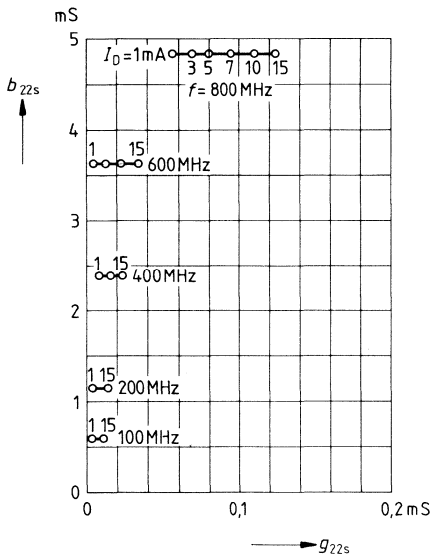

Test circuit 1 for power gain and noise figure

$f = 200 \text{ MHz}$, $G_G = 2 \text{ mS}$, $G_L = 0,5 \text{ mS}$

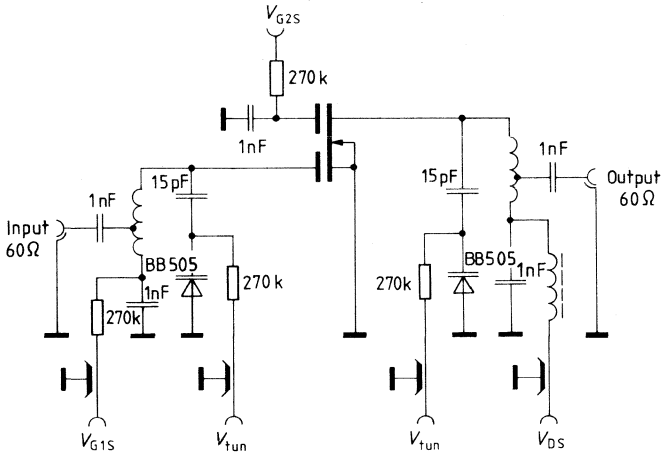

Test circuit 2 for power gain, noise figure and cross modulation

$f = 800 \text{ MHz}$, $G_G = 2,5 \text{ mS}$, $G_L = 0,8 \text{ mS}$

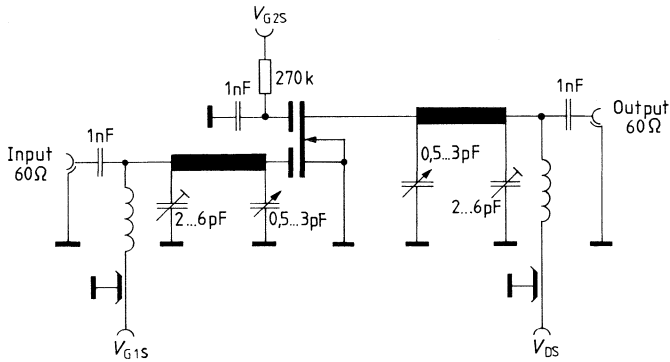

- Integrated suppression network against spurious VHF oscillations
- For VHF applications, especially in TV tuners with extended VHF band, e.g. in CATV tuners
- Miniature plastic package for surface mounting (SMD)

SOT 143

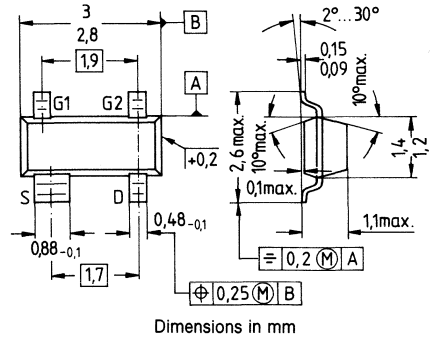

Type	BF 997	
Ordering code	bulk: Q62702-F993	taped: Q62702-F1055
Marking	MK	

Maximum ratings

Drain-source voltage	V_{DS}	20	V
Drain current	I_D	30	mA
Gate 1/gate 2 peak source current	$\pm I_{G1/2SM}$	10	mA
Total power dissipation	P_{tot}	200	mW
$T_A \leq 60^\circ C$			
Storage temperature range	T_{stg}	- 55... + 150	$^\circ C$
Channel temperature	T_{Ch}	150	$^\circ C$

Thermal resistance

Junction — ambient	R_{thJA}	≤ 450	K/W ¹⁾
--------------------	------------	------------	-------------------

¹⁾ Package mounted on alumina 16.7 mm × 15 mm × 0.7 mm

Characteristics ($T_A = 25^\circ\text{C}$)

DC characteristics		min	typ	max	
Drain-source breakdown voltage $I_D = 10\ \mu\text{A}$, $-V_{G1S} = -V_{G2S} = 4\ \text{V}$	$V_{(BR) DS}$	20	—	—	V
Gate 1 source breakdown voltage $\pm I_{G1S} = 10\ \text{mA}$, $V_{G2S} = V_{DS} = 0$	$\pm V_{(BR) G1SS}$	8,5	—	17	V
Gate 2 source breakdown voltage $\pm I_{G2S} = 10\ \text{mA}$, $V_{G1S} = V_{DS} = 0$	$\pm V_{(BR) G2SS}$	8,5	—	17	V
Gate 1 source leakage current $\pm V_{G1S} = 5\ \text{V}$, $V_{G2S} = V_{DS} = 0$	$\pm I_{G1SS}$	—	—	50	nA
Gate 2 source leakage current $\pm V_{G2S} = 5\ \text{V}$, $V_{G1S} = V_{DS} = 0$	$\pm I_{G2SS}$	—	—	50	nA
Drain current $V_{DS} = 15\ \text{V}$, $V_{G1S} = 0$, $V_{G2S} = 4\ \text{V}$	I_{DSS}	2	—	20	mA
Gate 1 source pinch-off voltage $V_{DS} = 15\ \text{V}$, $V_{G2S} = 4\ \text{V}$, $I_D = 20\ \mu\text{A}$	$-V_{G1S (p)}$	—	—	2,5	V
Gate 2 source pinch-off voltage $V_{DS} = 15\ \text{V}$, $V_{G1S} = 0$, $I_D = 20\ \mu\text{A}$	$-V_{G2S (p)}$	—	—	2	V

Characteristics ($T_A = 25^\circ\text{C}$)**AC characteristics**

		min	typ	max	
Forward transconductance $V_{DS} = 15\text{ V}, I_D = 10\text{ mA}, V_{G2S} = 4\text{ V}, f = 1\text{ kHz}$	g_{fs}	15	18	—	mS
Gate 1 input capacitance $V_{DS} = 15\text{ V}, I_D = 10\text{ mA}, V_{G2S} = 4\text{ V}, f = 1\text{ MHz}$	C_{g1ss}	—	2,5	—	pF
Gate 2 input capacitance $V_{DS} = 15\text{ V}, I_D = 10\text{ mA}, V_{G2S} = 4\text{ V}, f = 1\text{ MHz}$	C_{g2ss}	—	1,2	—	pF
Feedback capacitance $V_{DS} = 15\text{ V}, I_D = 10\text{ mA}, V_{G2S} = 4\text{ V}, f = 1\text{ MHz}$	C_{dg1}	—	25	—	fF
Output capacitance $V_{DS} = 15\text{ V}, I_D = 10\text{ mA}, V_{G2S} = 4\text{ V}, f = 1\text{ MHz}$	C_{dss}	—	1	—	pF
Power gain $V_{DS} = 15\text{ V}, I_D = 10\text{ mA}$ $f = 200\text{ MHz}, G_G = 2\text{ mS}, G_L = 0,5\text{ mS}$ (test circuit)	G_{ps}	—	25	—	dB
Noise figure $V_{DS} = 15\text{ V}, I_D = 10\text{ mA}$ $f = 200\text{ MHz}, G_G = 2\text{ mS}, G_L = 0,5\text{ mS}$ (test circuit)	F	—	1	—	dB
Gain control range $V_{DS} = 15\text{ V}, V_{G2S} = 4 \dots -2\text{ V}, f = 200\text{ MHz}$ (test circuit)	ΔG_{ps}	50	—	—	dB

Total power dissipation $P_{tot} = f(T_A)$

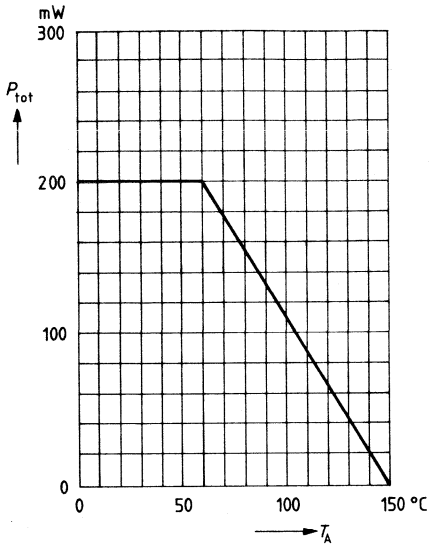

Output characteristics $I_D = f(V_{DS})$

$V_{G2S} = 4\text{ V}$

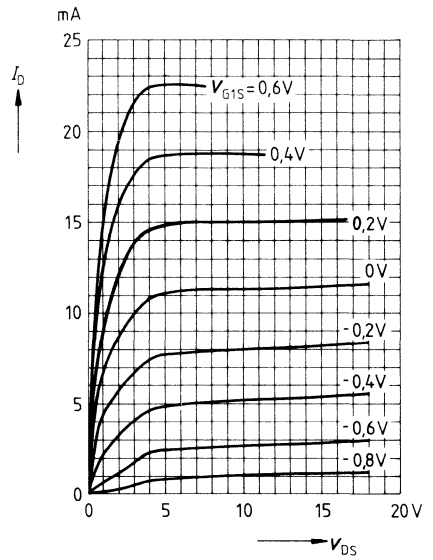

Gate 1 forward transconductance

$g_{fs1} = f(V_{G1S})$

$V_{DS} = 15\text{ V}, I_{DSS} = 10\text{ mA}, f = 1\text{ kHz}$

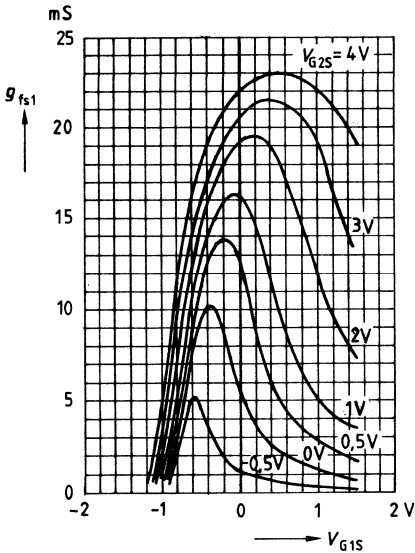

Gate 1 forward transconductance

$g_{fs1} = f(V_{G2S})$

$V_{DS} = 15\text{ V}, I_{DSS} = 10\text{ mA}, f = 1\text{ kHz}$

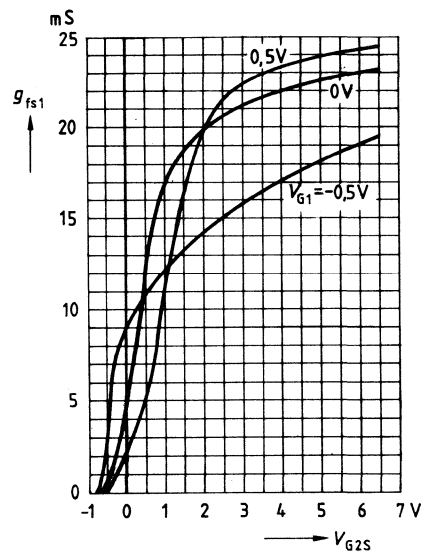

Drain current $I_D = f(V_{G1S})$

$V_{DS} = 15\text{ V}$

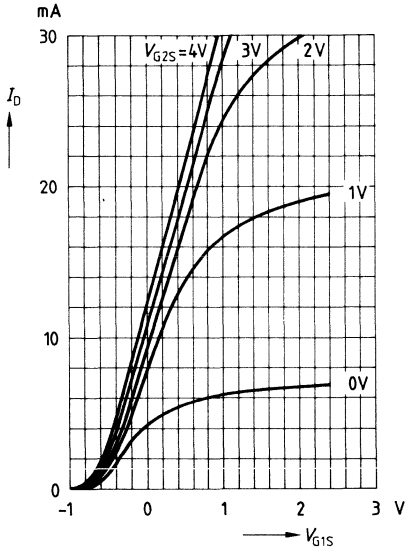

Gate 1 input capacitance $c_{g1ss} = f(V_{G1S})$

$V_{G2S} = 4\text{ V}, V_{DS} = 15\text{ V}$

$I_{DSS} = 10\text{ mA}, f = 1\text{ MHz}$

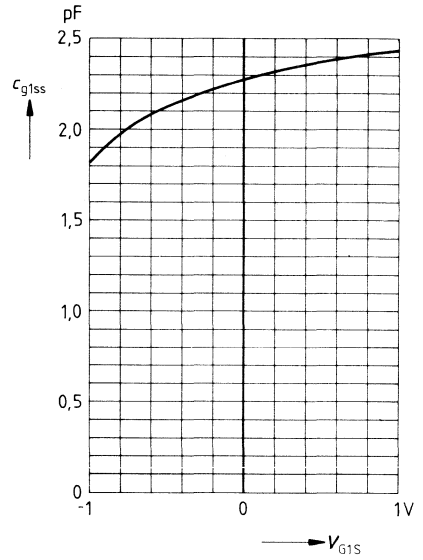

Gate 2 input capacitance $c_{g2ss} = f(V_{G2S})$

$V_{G1S} = 0\text{ V}, V_{DS} = 15\text{ V}$

$I_{DSS} = 10\text{ mA}, f = 1\text{ MHz}$

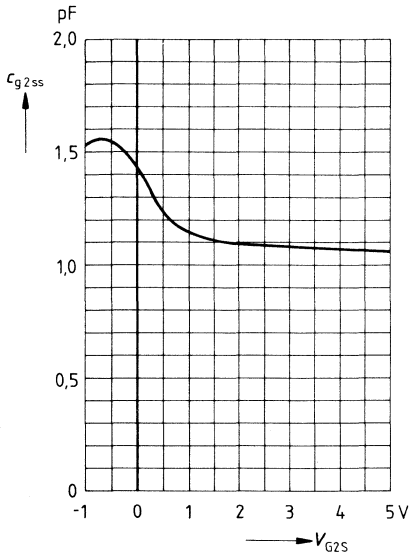

Output capacitance $c_{dss} = f(V_{DS})$

$V_{G1S} = 0\text{ V}, V_{G2S} = 4\text{ V}$

$I_{DSS} = 10\text{ mA}, f = 1\text{ MHz}$

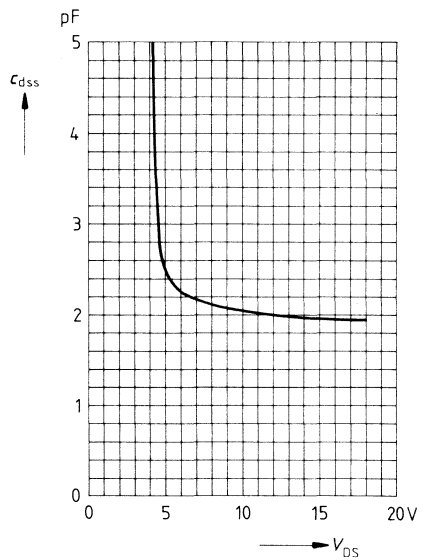

Gate 1 input admittance y_{11s}

$V_{DS} = 15 \text{ V}$, $V_{G2S} = 4 \text{ V}$
(common source)

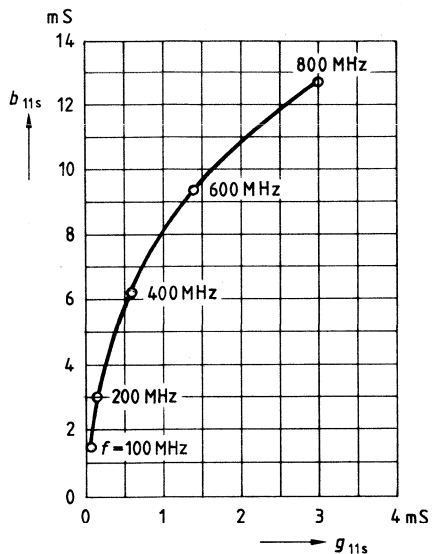

Gate 1 forward transfer admittance y_{21s}

$V_{DS} = 15 \text{ V}$, $V_{G2S} = 4 \text{ V}$
(common source)

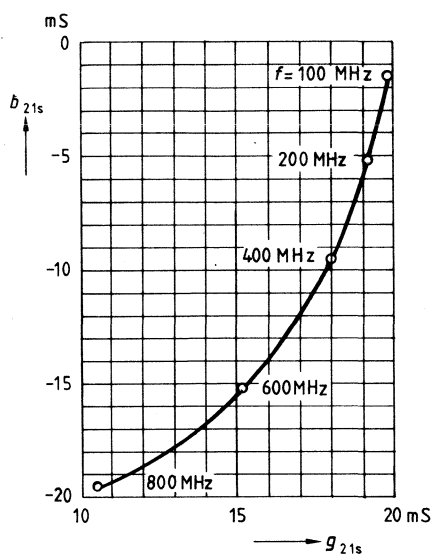

Output admittance y_{22s}

$V_{DS} = 15 \text{ V}$, $V_{G2S} = 4 \text{ V}$
(common source)

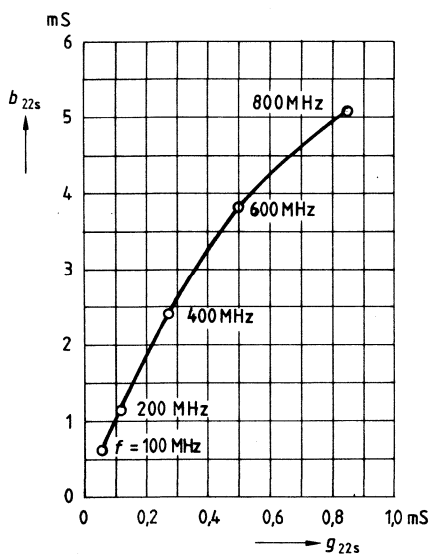

Power gain $G_{ps} = f(V_{G2S})$

$V_{DS} = 15\text{ V}$, $V_{G1S} = 0\text{ V}$
 $I_{DSS} = 10\text{ mA}$, $f = 200\text{ MHz}$
 (see test circuit)

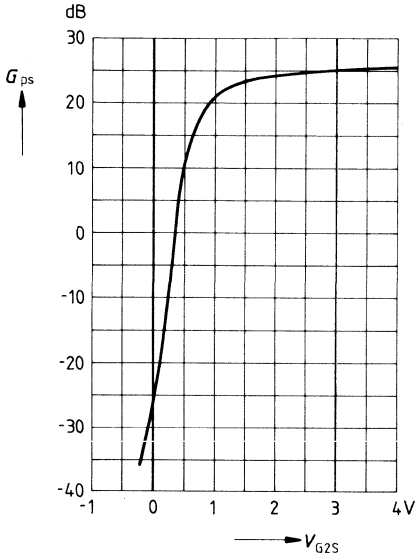

Noise figure $F = f(V_{G2S})$

$V_{DS} = 15\text{ V}$, $V_{G1S} = 0\text{ V}$
 $I_{DSS} = 10\text{ mA}$, $f = 200\text{ MHz}$
 (see test circuit)

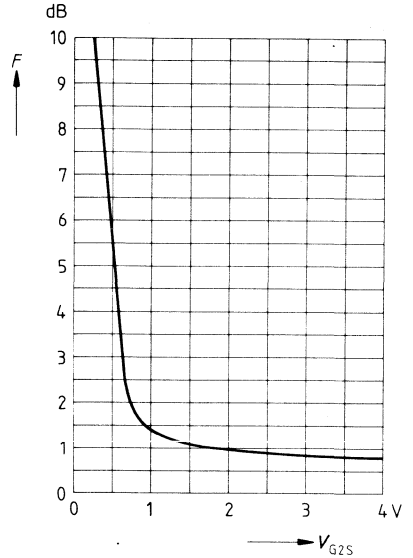

Test circuit for power gain and noise figure

$f = 200\text{ MHz}$, $G_G = 2\text{ mS}$, $G_L = 0,5\text{ mS}$

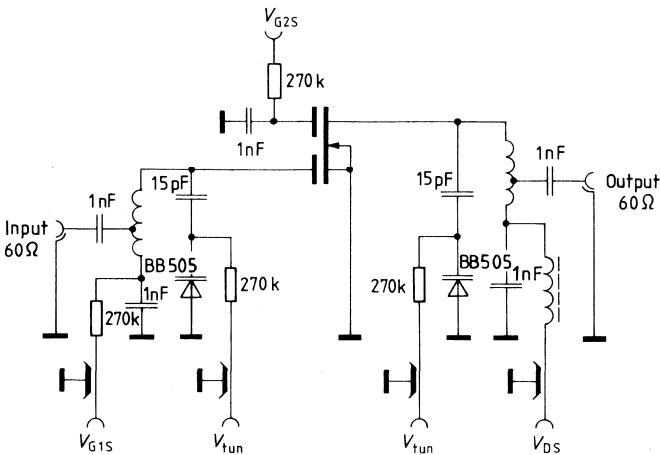

Siemens Worldwide
(Addresses)



Siemens AG, Bereich Bauelemente
Balanstraße 73, Postfach 80 17 09, **D-8000 München 80**
☎ (089) 41 44-0 ☎ 52 108-0 FAX (089) 41 44-26 89

Siemens Worldwide

Federal Republic of Germany and Berlin (West)

Siemens AG
Salzufer 6-8
1000 Berlin 10
☎ (030) 39 39-1, ☎ 1810-278
FAX (030) 39 39-26 30
Tlx 308190 = sieznb

Siemens AG
Lahnweg 10
Postfach 1115
4000 Düsseldorf 1
☎ (0211) 399-0, ☎ 8581301
FAX (0211) 399-2506

Siemens AG
Rödelheimer Landstraße 5-9
Postfach 1117 33
6000 Frankfurt 1
☎ (069) 797-0, ☎ 4 14 131-0
FAX (069) 797-2253

Siemens AG
Lindenplatz 2
Postfach 105609
2000 Hamburg 1
☎ (040) 282-1, ☎ 2 155 84-0
FAX (040) 282-2210

Siemens AG
Am Maschpark 1
Postfach 5329
3000 Hannover 1
☎ (0511) 129-0, ☎ 922 333
FAX (0511) 129-2799

Siemens AG
Richard-Strauss-Straße 76
Postfach 202109
8000 München
☎ (089) 9221-4380
☎ 529421-19
FAX (089) 9221-4390
Tlx 8985061

Siemens AG
Von-der-Tann-Straße 30
Postfach 4844
8500 Nürnberg 1
☎ (0911) 654-0, ☎ 6 222 51
FAX (0911) 654-4064

Siemens AG
Geschwister-Scholl-Straße 24
Postfach 120
7000 Stuttgart 1
☎ (0711) 2076-0, ☎ 7 23 941
FAX (0711) 2076-3706

EUROPE

Austria

Siemens Aktiengesellschaft
Österreich
Postfach 326
A-1031 Wien
☎ (0222) 72 93-0, ☎ 1372-0

Belgium

Siemens S.A.
chaussée de Charleroi 116
B-1060 Bruxelles
☎ (02) 536-2111, ☎ 21 347

Denmark

Siemens A/S
Borupvang 3
DK-2750 Ballerup
☎ (02) 65 65 65, ☎ 35 313

Finland

Siemens Osakeyhtiö
PL 8
SF-00101 Helsinki 10
☎ (0) 16 26-1, ☎ 124 465

France

Siemens S.A.
B.P. 109
F-93203 Saint-Denis CEDEX 1
☎ (1) 49 22 31 00, ☎ 620 853

Great Britain

Siemens Ltd.
Siemens House
Windmill Road
GB-Sunbury-on-Thames
Middlesex TW 16 7HS
☎ (09327) 85691, ☎ 8951091

Greece

Siemens AE
Voulas 7
P.O.B. 3601
GR-10210 Athen
☎ (01) 3293-1, ☎ 2 16 291

Ireland

Siemens Ltd.
Unit 8-11 Slaney Road
Dublin Industrial Estate
Finglas Road
Dublin 11
☎ (01) 302855, ☎ 32 547

Italy

Siemens Elettra S.p.A.
Via Fabio Filzi, 29
Casella Postale 10388
I-20100 Milano
☎ (02) 67661, ☎ 330261

Netherlands

Siemens Nederland N.V.
Postb. 16068
NL-2500 BB Den Haag
☎ (070) 782782, ☎ 31 373

Norway

Siemens A/S
Østre Aker vei 90
Postboks 10, Veitvet
N-0518 Oslo 5
☎ (02) 153090, ☎ 78 477

Portugal

Siemens S.A.R.L.
Avenida Almirante Reis, 65
Apartado 1380
P-1100 Lisboa-1
☎ (01) 538805, ☎ 12 563

Spain

Siemens S.A.
Orense, 2
Apartado 155
E-28080 Madrid
☎ (01) 4552500, 11x 27247

Sweden

Siemens AB
Hälsingegatan 40
Box 23141
S-10435 Stockholm
☎ (08) 7281000, 11x 19880

Switzerland

Siemens-Albis AG
Freitagstraße 28
Postfach
CH-8047 Zürich
☎ (01) 495-3111, 11x 823781

Turkey

ETMAŞ Elektrik Tesisati ve
Mühendislik A.Ş.
Mecidi Mebusan Caddesi 55/35
Findikli
PK. 1001 Karakoey
Istanbul
☎ (01) 1510900, 11x 24233

AFRICA

South African Republic

Siemens Limited
Siemens House,
P.O.B. 4583
2000 Johannesburg
☎ (011) 7159111, 11x 4-22524

AMERICA

Argentina

Siemens S.A.
Avenida Pte. Julio A. Roca 516
Casilla Correo Central 1232
RA-1000 Buenos Aires
☎ (01) 00541/300411, 11x 21812

Brazil

Siemens S.A.
Sede Central
Caixa Postal 1375,
01051 São Paulo-SP
☎ (011) 833-2211
11x 11-23641

Canada

Siemens Electric Limited
Electronic Components Division
1180 Courtney Park Drive
Mississauga, Ontario L5T 1P2
☎ (416) 673-1995
11x 06968049

U.S.A.

Power semiconductors:
Siemens Components, Inc.
Power Semiconductor Div.
2191 Laurelwood Road
Santa Clara, CA 950 54
☎ (408) 980-4500
Fax: (408) 980-4500
ext. 4104
11x 989791

Optoelectronic semiconductors:
Siemens Components, Inc.
Optoelectronic Division
19000 Homestead Road
Cupertino, California 95014
☎ (408) 257-7910
11x 352084 sie lit opto

All other products:
Siemens Components, Inc.
Special Electronics Division
186 Wood Avenue South
Iselin, New Jersey 08830
☎ (201) 321-3400
11x 844491

ASIA

Hongkong

Jepsen & Co., Ltd.
Siemens Division
P.O.B. 97
Hongkong
☎ (05) 8233777, 11x 73221

India

Siemens India Ltd.
Head Office
134-A, Dr. Annie Besant Road,
Worli
P.O.B. 6597
Bombay 400018
☎ 4938786, 11x 1175142

Japan

Fuji Electronic Components Ltd.
New Yurakucho Bldg., 8F
12-1, Yurakucho 1-Chome,
Chiyoda-ku
Tokyo 100
☎ (03) 201-2401, 11x 32182

Korea

Siemens Electrical
Engineering Co., Ltd.
C.P.O.B. 3001
Seoul
☎ (02) 275-6111, 11x 23229

Singapore

Siemens Components Pte. Ltd.
Promotion Office
10-15 E, 5th floor
47 Ayer Rajah Crescent No.06-12
Singapore 0513
☎ 7760044, 11x RS 21000

Taiwan

TAI Engineering Co. Ltd.
6th Floor Central Building
108, Chung Shan N. Rd. Sec. 2
P.O.Box 68-1882
Taipei
☎ 5363171, 11x 27860

AUSTRALIA

Siemens Ltd.
544 Church Street, Richmond
Melbourne, Vic. 3121
☎ (03) 4207111, 11x 304225

Table of Contents
Type Designation System

Selection Guide

Survey of Types

Application Reference Table

Cross Reference Table of Packages

Types and Ordering Codes

Explanation of Data Sheet Parameters
Quality Specifications

Packaging
Mounting Instructions

Diodes

Transistors

Siemens Worldwide
(Addresses)
